

Power Transmission Engineering®

DECEMBER 2014

THE **2014** BUYER'S
GUIDE ISSUE

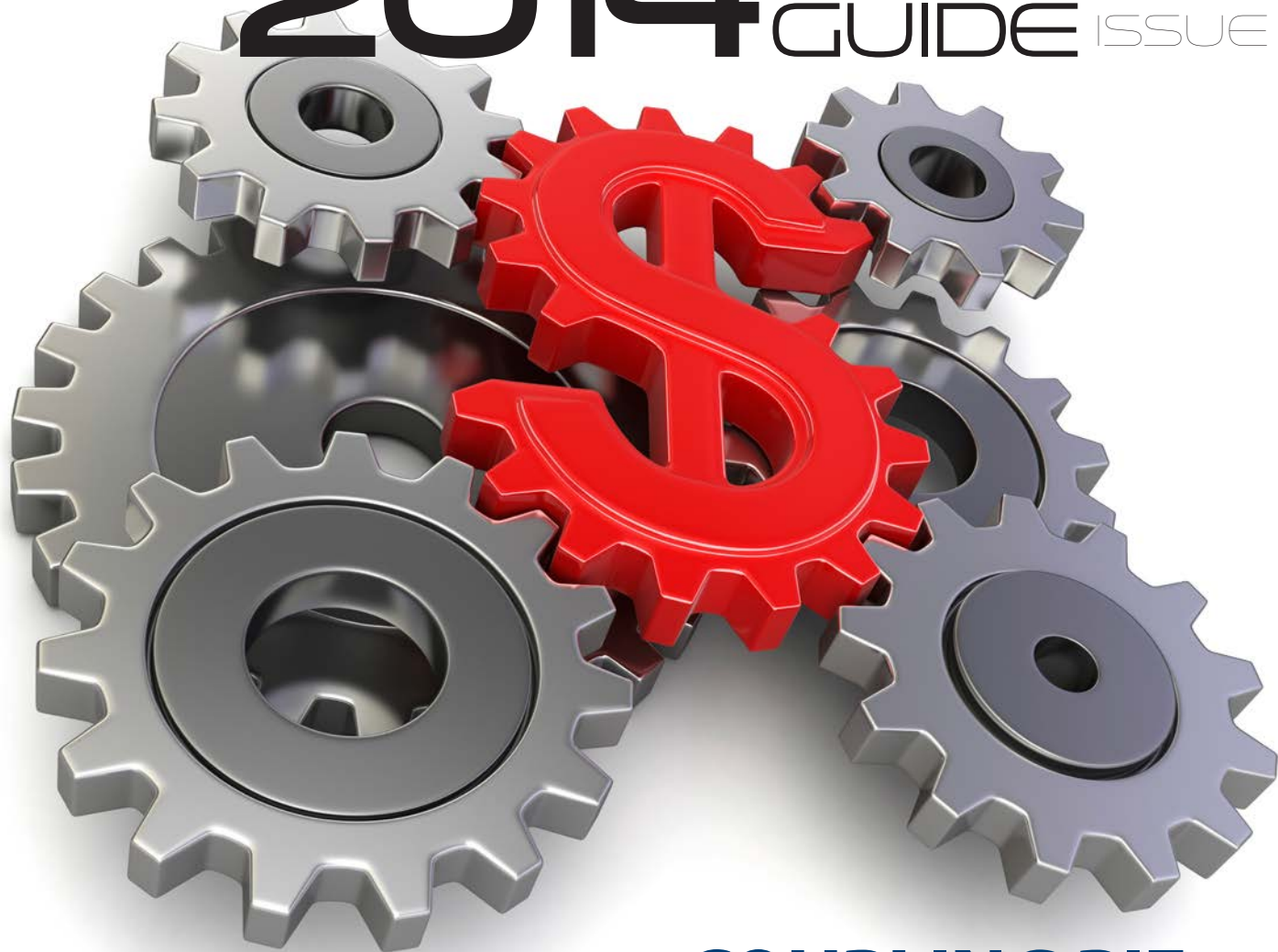

COUPLING PIE
WHO GOT A PIECE IN 2014
A COMPLETE RUNDOWN OF
THE SMALL MOTOR RULE

Get in gear!

with Ironhorse gearboxes

IronHorse worm gearboxes are manufactured using only the highest quality materials and are designed to withstand the toughest international and U.S. testing standards. Our gearboxes interface with C-face motors and provide reliable speed reduction, increased torque and dual load capabilities wherever it is needed.



IRONHORSE

Cast Iron Gearboxes

Cast-iron gearboxes are available with right-hand and dual (both right and left) output shafts, and hollow-bore outputs.

Features

- **Three output types: Dual Shaft, Right Hand Shaft and Hollow Shaft**
- **Four frame sizes: 1.75", 2.06", 2.37", 2.62" models with parallel or right-angle gear shafts**
- **Six ratios: 5:1, 10:1, 15:1, 20:1, 40:1, 60:1**
- **One-piece cast iron gear box housing, 1045 carbon steel shaft**
- **Double-lipped embedded oil seals to prevent gearbox leakage**
- **Universally interchangeable compact design ensures easy OEM replacement**
- **One year warranty**

Starting at:
\$147.00

NEW! Aluminum Gearboxes

Our new aluminum gearboxes are lightweight and durable, built with hardened steel worm shafts and hollow-bore outputs.

Features

- **Five frame sizes: 30, 40, 50, 63, 75 mm**
- **Two ratios: 10:1 to 100:1 (in most sizes)**
- **Input faces: 56C, 145TC, 182/4TC reversible design**
- **Aluminum alloy housing for lightweight design**
- **Two bearings on input and output shafts**
- **Double-lipped embedded oil seals to prevent gearbox leakage**
- **Multiple mounting holes for all angle mounts**
- **One year warranty**

Starting at:
\$88.00

Cast Iron Premium
Efficiency Motors



Rolled Steel General
Purpose Motors



Inverter-Duty
AC Motors



Also Available

Research, price, buy at: www.automationdirect.com/power-transmission

Order Today, Ships Today!



AUTOMATIONDIRECT.com
1-800-633-0405

the #1 value in automation

*See our Web site for details and restrictions. © Copyright 2014 AutomationDirect, Cumming, GA USA. All rights reserved.

Power Transmission Engineering®

DECEMBER 2014



[18]



[24]

[64]



2014 PTE BUYERS GUIDE

[28] 2014 PTE BUYERS GUIDE

Every supplier by category.

[48] BUYERS GUIDE: A to Z

Check out the Find-It-Fast Index.

FEATURE ARTICLES

[18] Getting a Piece of That Sweet Coupling Pie

Success of oil and gas buoy industry in 'very, very good year.'

[24] The Small Motor Rule — How Will This Affect You?

New federal regulations take effect in March 2015.

TECHNICAL ARTICLES

[62] Ask The Expert

Norm Parker talks pre-tension thrust bearings.

[64] Applications of Bevel Gears

A summary of the major applications for this high-tech gearing.

[70] The Latest Design Technologies For Gear Devices with Great Transmission Ratios

Four types of gear devices with great ratio gears (GRGs) are discussed.

[78] Finite Element Evaluation of Bearing Instrumentation Method

An evaluation of measurements taken on a 750kW turbine gearbox are tested by the NREL.

Vol. 8, No. 8. POWER TRANSMISSION ENGINEERING (ISSN 2331-2483) is published monthly except in January, May, July and November by Randall Publications LLC, 1840 Jarvis Ave., Elk Grove Village, IL 60007, (847) 437-6604. Cover price \$7.00. U.S. Application to Mail at Periodicals Postage Prices is Pending at Palatine, IL and at additional mailing offices. Send address changes to POWER TRANSMISSION ENGINEERING, 1840 Jarvis Ave., Elk Grove Village, IL 60007.

Randall Publications LLC makes every effort to ensure that the processes described in POWER TRANSMISSION ENGINEERING conform to sound engineering practice. Neither the authors nor the publisher can be held responsible for injuries sustained while following the procedures described. Postmaster: Send address changes to POWER TRANSMISSION ENGINEERING, 1840 Jarvis Avenue, Elk Grove Village, IL, 60007. ©2014 Contents copyrighted by RANDALL PUBLICATIONS, LLC. No part of this publication may be reproduced or transmitted in any form or by any means, electronic or mechanical, including photocopying, recording, or by any information storage and retrieval system, without permission in writing from the publisher. Contents of ads are subject to Publisher's approval.

Power Transmission Engineering

VOL. 8, NO. 8

QA1 GEZ SERIES

HIGH WEAR, HIGH LOAD SPHERICAL BEARINGS

QA1's GEZ Series fractured race spherical bearings are manufactured using 52100 bearing steel. This design allows for full ball to race conformity, resulting in reduced wear, smooth operation and less localized stress. A sealed version is also available. These spherical bearings are typical of high wear & high load applications such as hydraulic cylinders.



P: 800.721.7761
QA1.net/industrial

F: 952.985.5679
sales@QA1.net

Cabat®

A Division of A&E Incorporated

Designed to Protect™

Overload Release Clutches



Phone: 262.554.7500
Fax: 262.554.7503
www.cabatinc.com

- [04] **PTEExtras**
A little of this, some of that.
- [06] **Editorial**
We love math.
- [08] **Voices**
Tom Johnstone, President and CEO, SKF Group.
- [12] **Product News**
Newest equipment, software, etc.
- [84] **Global Industrial Outlook**
Houston, we have a problem.
- [86] **Industry News**
SMMA Fall Tech. Conf. report.
- [90] **Events**
Pack Expo, SMMA Conference
- [93] **Calendar**
January 5-9 – SciTech 2015, Kissimmee, FL.
January 26-28 – 2015 AHR Expo, McCormick Place, Chicago, IL.
February 4-6 – SEMICON Korea 2015, COEX, Seoul, Korea.
- [94] **Advertiser Index**
Advertiser contact information.
- [95] **Subscriptions**
Free subscriptions, anywhere in the world.
- [96] **Power Play**
The Model T: One Mean "Machine".



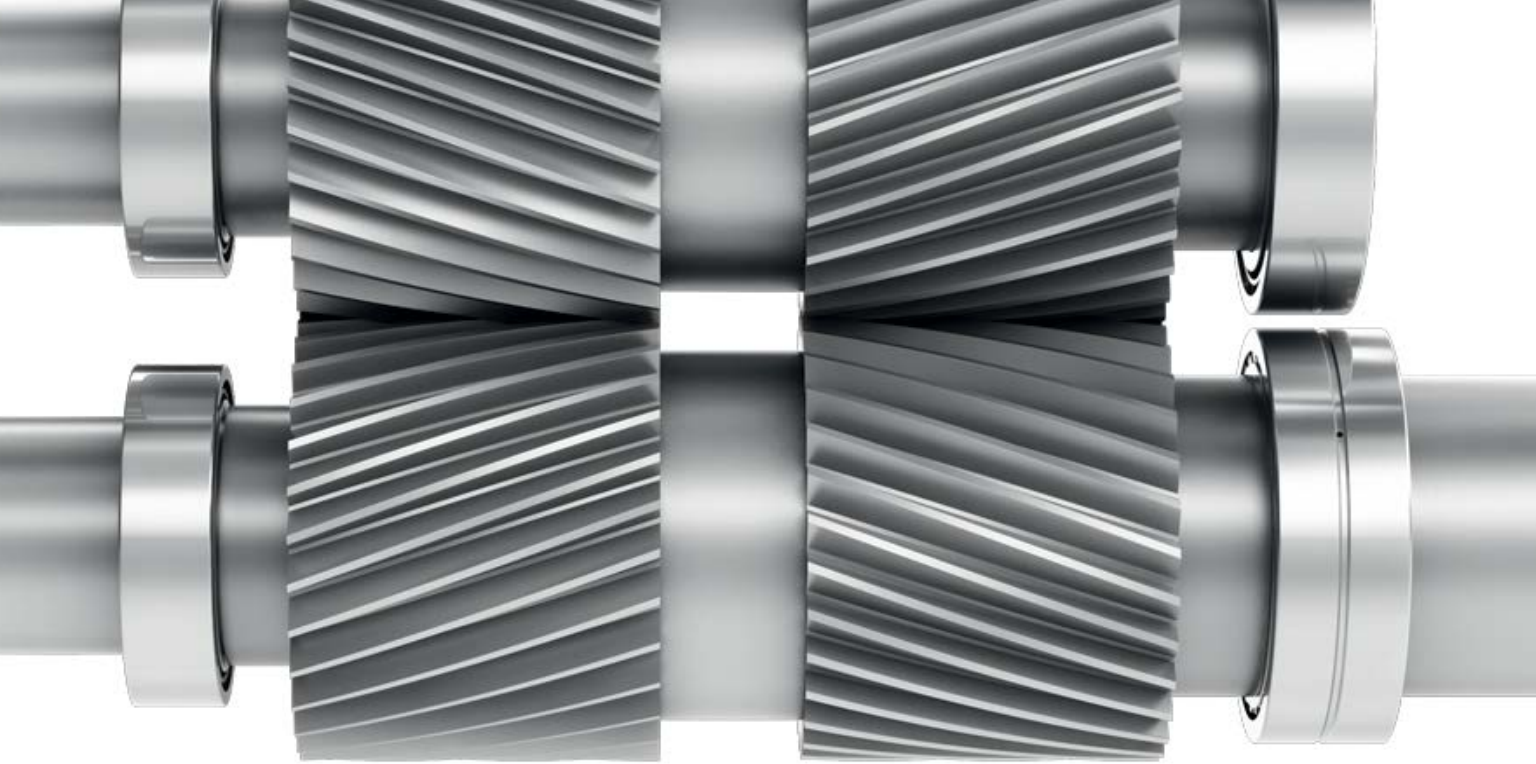

More torque. Less friction.



Enhance gear unit reliability and improve performance
Upgraded SKF Explorer self-aligning bearings have enhanced wear and contamination resistance, and are better able to sustain external loads – up to 20% more load for a given life of a gear unit.

Optimize gearbox units with upgraded SKF Explorer bearings

A robust solution for harsh and demanding gearbox environments, upgraded SKF Explorer bearings enable a gear unit to transmit more torque, sustain higher external loads, or even be downsized to improve cost efficiency.

In addition, these bearings provide substantially lower friction than other bearings. In fact, the friction can be reduced by 30% compared to the competition, enabling the gearbox to run cooler and more efficiently.

With expertise in bearings, sealing, and lubrication solutions, SKF engineers can add value to the complete gear unit by enhancing reliability and performance, while improving the cost-effectiveness of the complete solution.

For more information, please visit [skf.com](https://www.skf.com) or contact your local SKF representative.

PTE Videos

Vibration Damping and Anti-Sloshing

Demonstrated at Pack Expo in November, Bosch Rexroth's vibration damping technology addresses vibration reduction at the drive level, making it easier to implement on any master or controller. The unintended consequences of machinery vibration have negative effects on both your equipment and the products you manufacture. See an explanatory video at www.powertransmission.com.

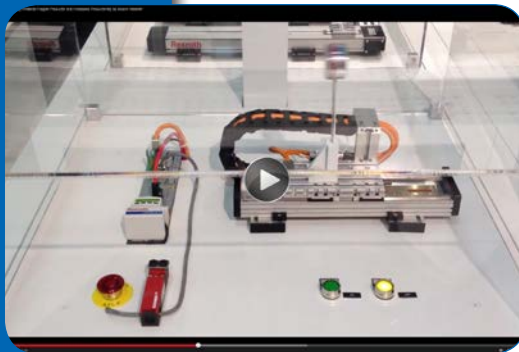

Proper Bearing Handling and Storage

Motion Industries' Tom Clark discusses proper bearing handling and storage in this Tom's Toolbox MiHow2. Learn the requirements SKF uses to ensure the proper handling and storage and the ways they maintain those requirements. See the video online at www.powertransmission.com.



Flashback: Planetary Gears

This video, produced in 1953 by the U.S. Department of Defense, demonstrates the operating principles of planetary gear sets used in automotive transmissions. Includes a short review of the three planet carrier laws. See it at www.powertransmission.com.



Stay Connected with Social Media



Follow us on Twitter
twitter.com/#!/PowerTransMag



Connect with us on LinkedIn
www.linkedin.com/groups/Power-Transmission-Engineering-PTE-2950055



Subscribe Online
www.powertransmission.com/subscribe.htm

More Videos Online

There are lots more videos online on a wide variety of mechanical power transmission and motion control topics. Visit www.powertransmission.com/videos/index.php to see them all.

Power Transmission Engineering

Randall Publications LLC
1840 Jarvis Avenue
Elk Grove Village, IL 60007
Phone: (847) 437-6604
Fax: (847) 437-6618

EDITORIAL

Publisher & Editor-in-Chief
Michael Goldstein

publisher@powertransmission.com

Managing Editor & Associate Publisher
Randy Stott

wrs@powertransmission.com

Senior Editor

Jack McGuinn

jmcguinn@powertransmission.com

Assistant Editor

Erik Schmidt

erik@geartechnology.com

Editorial Consultant

Paul R. Goldstein

ART

Art Director

David Ropinski

dropsinski@powertransmission.com

ADVERTISING

Advertising Sales Manager & Associate Publisher

Dave Friedman

dave@powertransmission.com

China Sales Agent

Eric Wu

Eastco Industry Co., Ltd.

Tel: (86)(21) 52305107

Fax: (86)(21) 52305106

Cell: (86) 13817160576

eric.wu@eastcotec.com

Materials Coordinator

Dorothy Fiandaca

dee@randallpublications.com

DIGITAL

Content Manager

Kirk Sturgulewski

kirk@powertransmission.com

CIRCULATION

Circulation Manager

Carol Tratar

subscribe@powertransmission.com

RANDALL PUBLICATIONS STAFF

President

Michael Goldstein

Accounting

Luann Harrold



I Rely on Arrow Gear



High Quality Spiral Bevel Gears from Stock!

Arrow Gear Company is widely known as a leading producer of high precision custom made gears. But every day, thousands of manufacturers around the world rely on the precision offered by Arrow's line of high capacity stock gears.



Arrow offers a wider range of stock precision spiral bevels than any other catalog - up to 16 inches in diameter - including ground tooth gears. Featuring carburized and hardened teeth, all gears are produced in matched sets for maximum capacity, and are available for immediate delivery. Modifications can also be performed to meet individual customer needs - a cost saving alternative to one of our custom designs.

With over 65 years experience, Arrow's stock gears are manufactured with the same processes used for our custom aerospace products. With a state-of-the-art production facility and dedicated personnel who are among the best in the business, Arrow Gear offers the expertise and precision for the most demanding quality requirements.

**When you need quality, expertise, and precision,
you can rely on Arrow Gear!**



Visit Arrow Gear's
Virtual Tour at
www.ArrowGear.com/tour

The Precision Gear Specialists



**ARROW
GEAR
COMPANY**

www.ArrowGear.com
6 3 0 . 9 6 9 . 7 6 4 0

Encouragement and Enthusiasm

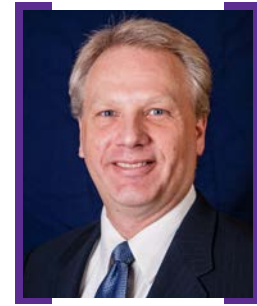

In the Stott household, we love math.

Well, maybe not *everyone* in my household loves it equally, but since they were in kindergarten, whenever one of my children asked me for help with math homework, my reply has been an instant and cheerful “We love math!”

In fact, that ritual has occurred so often that the mantra of “we love math” has become ingrained. Ask any of my four kids what the family motto is, and they know the drill. They’ll respond with “We love math,” even if they do roll their eyes when they say it. The point is, my wife and I have tried to encourage in our children an enthusiasm for learning—not just for math, but also for science, foreign languages, music, literature and a wide variety of other subjects. Without that encouragement, the Stott family motto could easily have been “We love ice cream”—trust me on this one—but instead, it’s “We love math.”

So I was delighted when my eighth grade daughter, Emily, invited me to go with her to a STEM (science, technology, engineering and mathematics) event sponsored by our county’s regional office of education. The event was set up specifically for girls and their parents, and it was designed to encourage young women to pursue studies and careers in technical fields.



Emily Stott closing the circuit on her “Bristle Bot.”

Since, you know — we love math — we just had to go.

It was a prestigious honor for my daughter. A maximum of three kids from each school were invited, and it took place at Argonne National Laboratory near Lemont, IL. More importantly, it was a great opportunity for her to hear from a number of women working in STEM fields about what they do on a day-to-day basis and how they got there.

The keynote speaker was Jillian Arnold, a cinematographer and work flow specialist. You might not think that cinematography has much to do with STEM careers, but that’s before you learn that Arnold shoots video for NASA’s Jet Propulsion Laboratory and that a “workflow specialist” is someone who handles and processes digital media between the time it’s shot in production to the time it’s edited in studio.

Her job involves computers, software and technical equipment, and she has to understand the technology of that equipment as well as the physics of lighting. Her talk was not only inspirational, but also put a face and a personality with the technology.

The event also included break-out sessions where the students were able to do some hands-on projects, such as building a table out of newspaper and masking tape, and constructing a miniature robot. They also heard from a panel of speakers including a computer simulation specialist from Argonne National Laboratory, a mechanical engineer specializing in nuclear power plants and a zookeeper from Brookfield Zoo.

For me, the most important part about this event was connecting the dots. Kids go to school, and they study math and science because they have to, but nobody explains how these often abstract concepts will ever relate to their real life. When will they ever have to solve for X or prove that two corresponding angles are equal? Shooting videos of rocket launches is a lot more interesting to kids than doing math problems. So is being a zookeeper. So is working in a nuclear power plant or programming one of the world’s most powerful supercomputers. There are a wide variety of STEM-related careers, but if kids aren’t exposed to them, they’ll never connect the dots, and they’ll see their schoolwork as drudgery.

If you’re reading this, you probably work in a STEM-related field—maybe even one of the really cool and interesting ones. You probably also know some young people who haven’t yet decided what they want to be when they grow up. I challenge you to share your enthusiasm and help them see the possibilities.

Maybe they’ll learn to love math, too.

Randy Stott

SCHAEFFLER



Stop Downtime from Bottling Up Your Profits!

Uncork Some Schaeffler Reliability with KUBE

Schaeffler's innovative 4-row linear recirculating ball bearing and guideway system, KUBE is designed to keep your packaging machines moving by effectively vanquishing those dreaded causes of downtime: inadequate lubrication and contamination. Featuring our exclusive X-life™ technology, KUBE is synonymous with extra-long maintenance intervals and maximum productivity.

SUPERIOR LUBRICATION • OPTIMUM SEALING

With an integrated, patented lubrication channel in the carriage's load zone that stores grease where it's needed and an innovative one-way lubrication valve that ensures consistent grease flow, **KUBE delivers longer lubrication intervals than any competitor's bearings on the market.** Meanwhile, advanced, low-friction seals offer optimum protection against contamination with minimal displacement resistance.

Choose KUBE and bottle up downtime, not your profits!

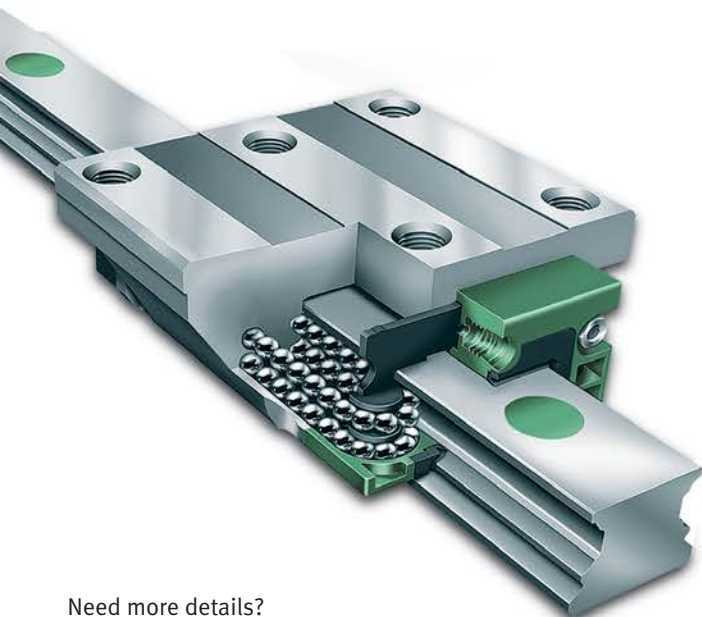

Need more details?
Please contact us at ads.ind@schaeffler.com
www.schaeffler.us

Superior-quality products.
Comprehensive reliable solutions.



The American Industrial Renaissance

Tom Johnstone, President and CEO, SKF Group



At SKF, we believe in the long-term development of the U.S. industrial economy.

The reindustrialization is supported by a strong university-based research network, a competitive workforce and energy supply from domestic energy resources. However, there are still challenges, particularly regarding the availability of skilled labor. Business, education and governments have a responsibility to work together to ensure this is not the bottleneck in U.S. industrial development. I am particularly pleased with and support the work the National Association of Manufacturers is doing in this area.

I also welcome the recent joint U.S.-China announcement on climate change, which states “technological innovation is essential... for new zero- and low-carbon technologies.” I think this will be a driver for upgrading or replacing older, less efficient plants and equipment, whether it’s for the latest generation of electric vehicles, jet engines or multi-megawatt wind turbines. There is a growing demand for highly efficient, highly reliable solutions, and SKF can play an important role in this development.

Over the last few years SKF has stepped up its investment in innovation and in our North American presence. We have been active in the United States since 1912, but during the last five years we have invested over \$2.5 billion in North America in acquisitions, new facilities and upgrades. The single largest SKF Group investment to date has been the acquisition of U.S.-based Kaydon Corporation in 2013. This helped complete our bearing and sealing solution product portfolios, strengthening our offerings in industries from renewables, marine and medical, to oil and gas.

Kaydon also quickly expanded our manufacturing footprint in the U.S.,

adding 13 manufacturing facilities to our existing 33 U.S. plant locations.

Innovation is the lifeblood for a company like SKF, and we are continuing to step up our investments in this area. We have just broken ground on a new \$30 million Global Technical Center - Americas, located near Chicago. It will focus on working closely with our customers to develop even more energy-efficient solutions, which will become part of our BeyondZero portfolio. This portfolio brings together many products and applications that deliver real energy savings for our customers. One good example in the United States is how we have worked closely with Spencer Pump on an aeration blower pump using our magnetic bearing system and permanent magnet motors to help significantly reduce energy used in waste water treatment.

The new U.S. technical center, scheduled to open by the end of next



(From left): Poul Jeppesen, President and CEO of SKF USA Inc., A. George Pradel, Mayor of Naperville, IL, and Tom Johnstone, President and CEO of the SKF Group, break ground on the company's new Global Technical Center - America. The groundbreaking took place in November, and the facility should be open by the end of 2015.



Artist's rendering of the new SKF technical center being built near Chicago.

CUSTOM

BEVEL GEAR MANUFACTURING

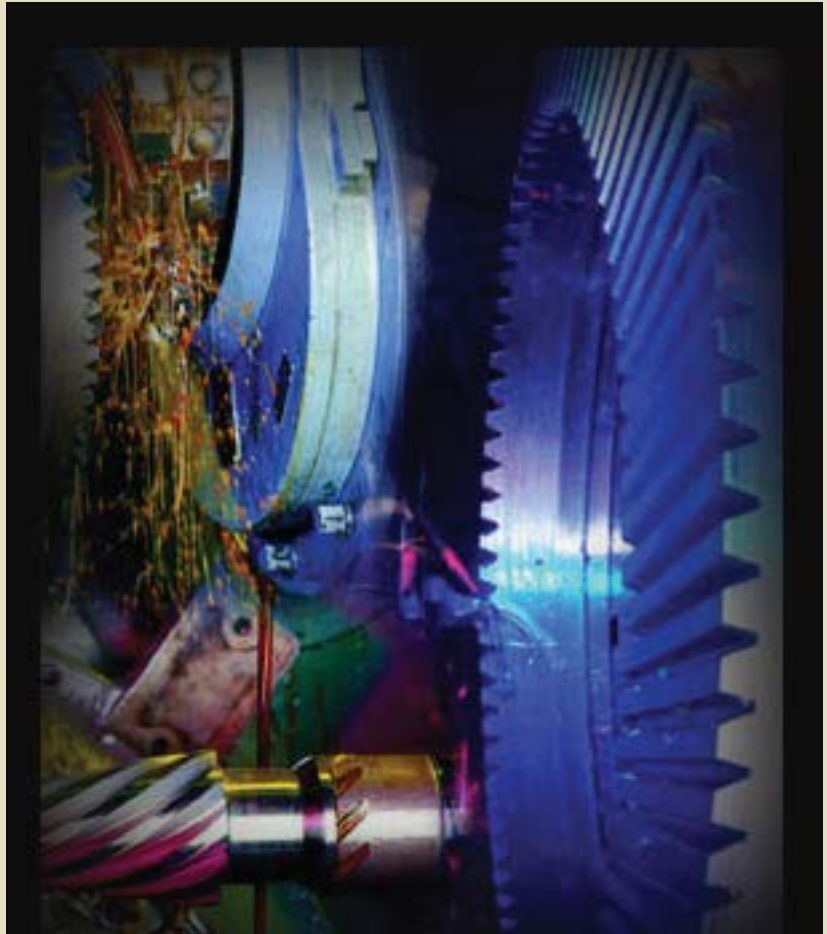
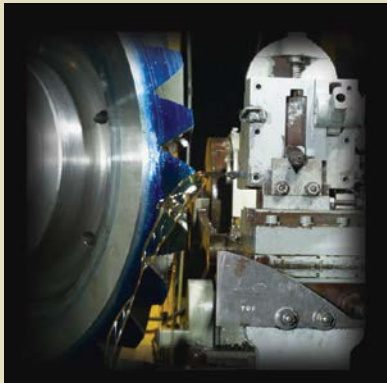
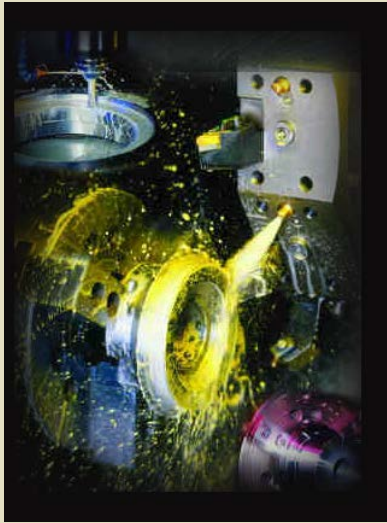

REVERSE ENGINEERING

BREAKDOWN SERVICES

IN-HOUSE STEEL MATERIAL WAREHOUSE

STRAIGHT BEVEL GEARS: 80" PD

SPIRAL BEVEL GEARS: 66" PD

FULL HEAT TREATING SERVICES

SPURS, HELICALS, SPLINE SHAFTS

GEARBOX REPAIR/REBUILDS

EDM WIRE BURNING

B&R

Machine and Gear Corporation

Toll Free: (800) 238-0651

inquiry@brgear.com • www.brgear.com



Extensively Applied to Photovoltaic Power Plants in Upington of South Africa and Lalackama of Chile

- ★ 25-year manufacturing experience
- ★ More than 70 patent products, 50% of our products are sold to all over the world
- ★ Qualified supplier for Chinese army
- ★ Both OEM and ODM available
- ★ With R&D center and testing center (CNAS)



High efficiency and high torque slewing drive

- ◆ High torque-low speed slewing drive for uniaxial or biaxial photovoltaic trackers
- ◆ Using slewing bearing and double enveloping hourglass worm gear enables multi-tooth contact.
- ◆ mesh precision is up to 0°
- ◆ Main components are made of Al bronze and carburizing steel which features high transmission torque, stable operation, and facilitates supporting larger radial, axial load and high tilting moment simultaneously

Aluminum bronze cage with the oil film guided wedge angle



LUOYANG SBI SPECIAL BEARING CO., LTD.

Add: Weisi Road, Luoyang Industrial Park, Xigong, Luoyang,
Henan Province, P.R. China

Tel: +86 379-64122001 | Fax: +86 379-64122006

Email: wd@sbi.com.cn; Judy@sbi.com.cn

Website: www.sbibearings.com



year, completes a global network of centers including new facilities in India, China, the Netherlands and Sweden. It is part of our strategy to more rapidly bring our technology even closer to where it's most needed—to our customers. As part of this effort, the center will include something we call an SKF Solution Factory. It is part engineering center, part manufacturing center, and it helps apply and

“We believe that the United States will play an important role in the development of a new low-carbon economy and in the industrial ‘smart’ revolution, or the internet of things that now includes industrial devices.”

deliver technology solutions to meet the needs of its local customers. We opened our sixth in North America in Birmingham, AL in October and it was our 29th in the world.

In summary, I think we are in the early stages of an industrial renaissance in the United States. We believe that the United States will play an important role in the development of a new low-carbon economy and in the industrial “smart” revolution, or the internet of things that now includes industrial devices. We are embedding sensors in our components and linking them into intelligent systems that can reach new levels of energy efficiency, reliability and cost effectiveness. Today SKF is already a leader in stand-alone condition monitoring systems, and for tomorrow we see these self-powered, micro-sized sensors as key additions to bearings and related components in critical applications.

With our global technologies, combined with the local investments we have been making, I am confident SKF will play a key role in the development of sustainable solutions to secure profitable and responsible growth in this dynamic market. **PTE**

YOUR MECHANICAL ADVANTAGE



Every detail matters. Consistency, precision and quality are key. Fortunately for you, that's where First Gear excels.

Not just the ability to innovate. The ability to ensure each step is done correctly. Prototyping, hobbing, skiving, grinding, shaping, finish rolling, contract inspection, hob sharpening and more, we do it all.

And better yet. We do it all extremely well.

First Gear. YOUR MECHANICAL ADVANTAGE

FIRST GEAR

ENGINEERING & TECHNOLOGY

www.first-gear.com

7606 Freedom Way
Fort Wayne, Indiana 46818
Tel: (260) 490-3238

Maxon Motor

EXPANDS X DRIVES LINE

Two years ago, Maxon Motor introduced a new generation of brushed DC motors – the Maxon X drives.

Now, four more motor sizes are being added to the existing portfolio. The 14, 16, 22 and 26 millimeter diameter models are now each available in a long version (L), which offers higher continuous torque and higher continuous output power.

At the same time, Maxon Motor is introducing four new GPX planetary gearheads, in the sizes 14, 19, 26 and 37 millimeters, compatible with existing products in



the program. These gearheads are designed with scaled gear stages. Each of the new three-stage gearheads can be driven with the next smaller motor. This results in the drive system being smaller, lighter and more economical.

The existing GPX 16 and GPX 32 models are available in various versions and can be equipped with ceramic axles to reduce wear. Customers looking for a particularly low-noise gearhead have the option of choosing plastic planetary gears.

Maxon also expanded its encoder portfolio. The new ENX 16 Easy absolute encoder is available as an SSI or BiSS-C version, according to the customer's requirements.

For more information:

Maxon Motor
Phone: (508) 677-0520 ext. 113
www.maxonmotorusa.com

LM76

DEBUTS THREE NEW LINEAR ROLLER BLOCK AND RAIL SYSTEMS

Low cost, Saibo SB-LGB linear roller block and rail systems are now available from LM76 in three sizes to meet load requirements up to 1,200 newtons (270 pounds).

These narrow profile linear motion systems feature low noise, smooth travel, high speed up to 10 meters per second, high acceleration up to 50 meters per second, low weight, high linear accuracy, sealed radial low friction bearings and low cost. Due to their narrow profile they are easy to install into new and existing applications.

Saibo SB-LGB linear roller block and rail systems have an adjustable preload system to control the required level of precision needed for most applications. The roller block has six drilled and tapped holes for mounting tooling, cameras, test equipment and more. They can be used in robotics, assembly, pick-and-place, sorting, pack-



aging, manufacturing, sampling, laser cutting, wafer handling and other precision applications. The rail systems are protected from debris, dust, chips and contaminates by plastic end caps with spring loaded oil filled felt pads. The felt wiper pads also deliver lubrication to the guide and rollers. The wipers are easily re-lubricated through convenient oil ports in the end cap.

For more information:

LM76
Phone: (413) 525-4166
www.lm76.com

Redex

OFFERS INCREASED VERSATILITY WITH NEW GEARS

Versatility is the key issue for manufacturers of multi-axis milling machines and vertical turning lathes. The same machine must be able to perform various milling and lathing operations so that machining operations can be carried out with the highest accuracy (without part disassembly) and the highest productivity.

Until now, these constraints meant that manufacturers had to use drives that were generally complex and did not necessarily meet every technical requirement. Redex offers two complementary integrated drives for tables used on milling machines and vertical lathes. They allow designers to choose the right drive for each application and

based on their priorities of speed, power, accuracy and rigidity.

Redex's high-speed versions of its DRP, KRP and KRPX ranges complement the features of its MSR range of drives. They simplify the design of the mechanical transmission systems of both large rotary tables used on vertical lathes (over 2,000



From the Forest City Gear Family To You and Yours...Merry Christmas

The Holiday Season gives us an opportunity to pause in our busy schedules and reflect on the many blessings we've received throughout the year. We give thanks for our great customers, our skilled and dedicated family of employees, friends and family and the continued joy of working in the industry we love.

From all of us at Forest City Gear, we wish you a very Merry Christmas and may your 2015 be a joyous and prosperous one.



11715 Main Street, Roscoe, IL 61073

815-623-2168

www.forestcitygear.com

sales@forestcitygear.com

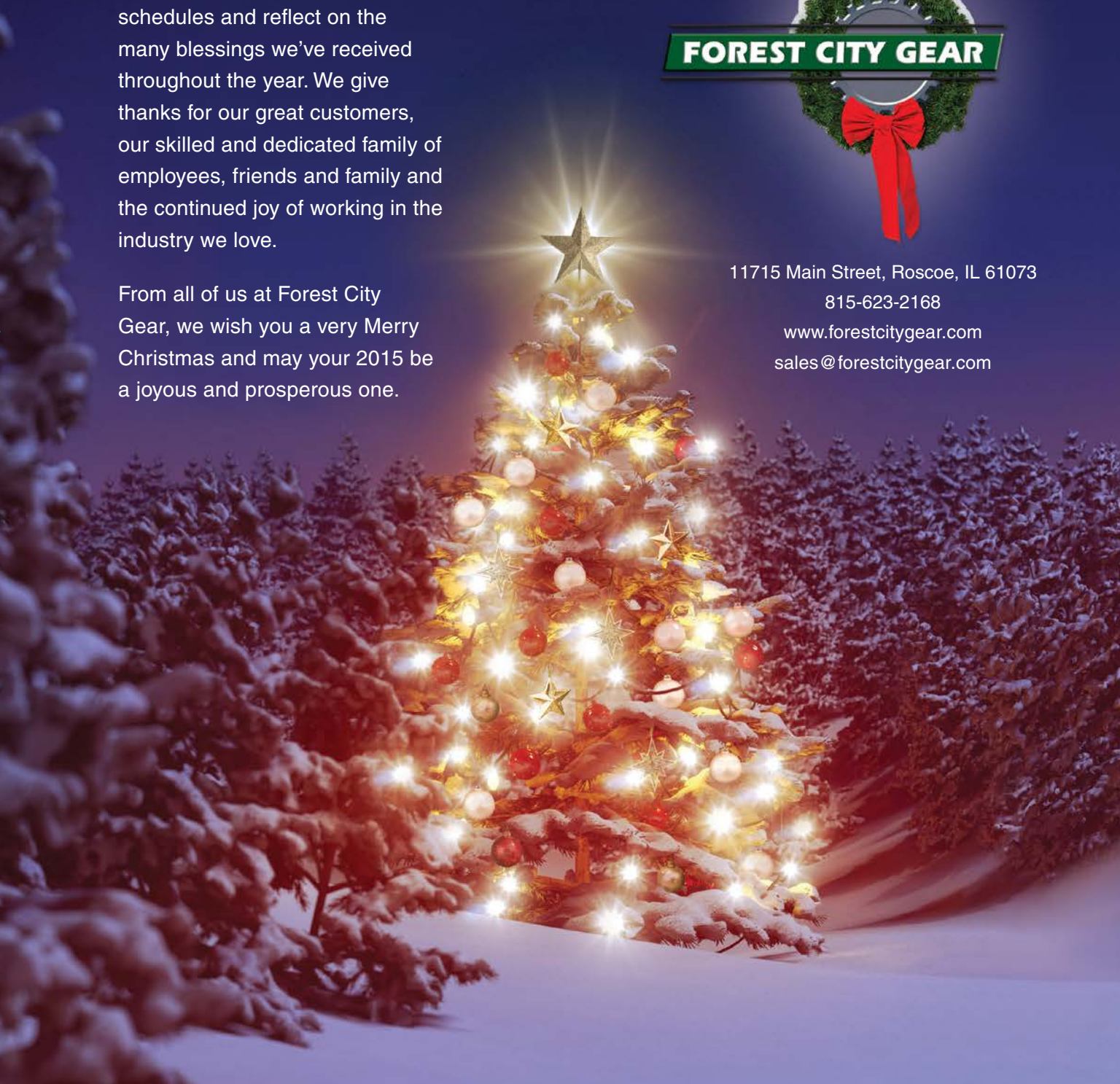

meters) and smaller tables used on milling machines. They also improve machine accuracy and allow for smaller machine footprints.

When meshed with a drive gear, the two reducers on Redex TwinDrive and DualDrive solutions cancel 100 percent of backlash. These high-speed reducers have been hardened to allow continuous operating cycles and meet the specific requirements of rotary tables. As a result, Redex high-speed TwinDrive and DualDrive units can achieve rotational speeds of up to 28 rotations per minute.

Although the Redex MSR range offers higher rotational speeds, the high-speed versions of its DRP, KRP and KRXP drives offer greater accuracy, rigidity and momentum. They are the standard drives with the highest positioning accuracy.

The complementarity of both solutions allows manufacturers to design the right rotary-table drives for specific applications and thus their priorities of speed, power, accuracy and rigidity.

Redex solutions make it possible to execute additional functions on the C-axis without any additional mechanical devices or the use of position locking. This maximum accuracy is maintained during milling and/or positioning operations particularly by the electrical or mechanical preload system, which continuously manages the counter-torque between the pinions.

Solutions that use two reducers, and thus two motors, are more cost effective and easier to manage in most cases. Compared to heavy-duty rotary tables used in conventional configurations that require a 160-kW motor, the TwinDrive solution uses two 80-kW motors, which are more standard and often less expensive. Maintenance and spare-parts management is also simplified by the use of the smaller, standard motors. This simplifies rotary-table design because it eliminates the need for machine-tool manufacturers to design and build their own gearboxes with all the necessary components.

For more information:

Redex SA
Phone: +(33) 2 38 94 42 62
www.cfourtune@redex.fr

Suhner

SOLVES NOISE ABSORPTION FOR POWER SEAT

Less noise, less vibrations, less distractions, more comfort; all this is required in today's global automotive industry. The power seat manufacturers are demanding innovation on the level of the component manufacturer.

Using patented innovations in conjunction with state-of-the-art manufacturing technologies, Suhner addresses these needs.

Through scientific experiments in Suhner's R&D laboratory as well as through a well-respected university in the United States, Suhner has found the ideal combination of materials together with the best manufacturing techniques.

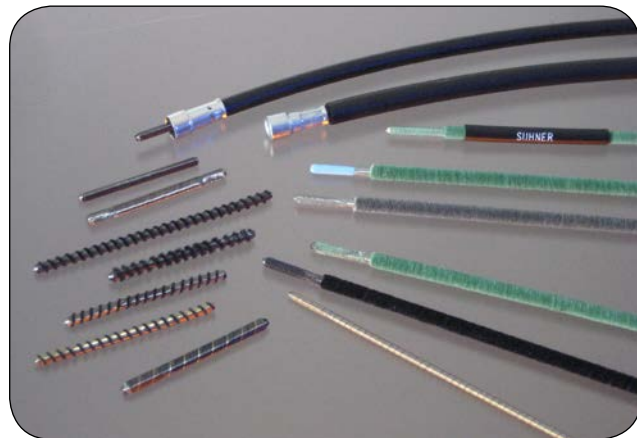

Suhner's research found that the main noise source is the drive motor and its load, so the mission was to dampen these noise levels with the components that Suhner is manufacturing - the flexible drive shaft that is rotating inside a plastic casing. The combination of materials used together with how they are manufactured is the secret to the lowest noise levels for the entire power seat system.

For more information:

Suhner Manufacturing, Inc.
Phone: (706) 235-8046
www.suhner.com

Siemens

UPGRADES SIMATIC 427D MICROBOX IPC WITH THIRD GENERATION INTEL PROCESSOR

Siemens Simatic 427D Microbox IPC has been upgraded with the third generation Intel Core i7 (1.7 GHz) processor for high system performance in demanding industrial applications. A turbo-boost feature delivers up to 2.4 GHz for maximum computing and control performance.

The IPC's DDR3 memory technology offers up to 8-GB RAM. The expandable mass memory is configurable with Fast Cards up to 16 GB, SSD (Solid State Drive) with 50 GB (high endurance) or 80 GB (standard) for robust requirements or a 2.5" hard disk with 250 GB. Memory options include a 250 GB hard disk, a DVD drive and a non-volatile memory of up to 512 KB for non-battery applications.

The fanless IPC operates in temperatures up to 55 degrees Celsius. Highly reliable where vibration and shock loads are present, it safeguards against voltage failure with NVRAM for WINAC RTX (soft PLC). It also offers a retentive signaling buffer for WinCC and image security with an enhanced write filter function.

The rugged housing has good chemical resistance against oil and grease with a smooth front to resist dirt build-up.

Downtime is also reduced and fault recognition enhanced with a self-diagnostic feature.

The unit offers up to two PCIe expansion slots. Four USB 3.0 interfaces located on the back of the IPC and one USB 2.0 interface in front quickly

ATC Diversified Electronics

INTRODUCES LATEST SUMP PUMP MOTOR

ATC Diversified Electronics, a division of Marsh Bellofram Corporation, has introduced the Model SPM 120AAA single-channel shaft seal monitoring module for submersible pump motor applications.

Model SPM 120AAA provides early warning of possible motor shaft seal leakages and failures. When used as part of an effective predictive maintenance strategy, the module can help reduce the risks of premature equipment failure and downtime over 10 million mechanical cycles and fifty thousand electrical operations. Offered with choices of both fixed and adjustable sensitivities, the Model SPM 120AAA detects a pump motor shaft seal leak by sensing the position of a resistive float switch or pair of conductive probes installed within the seal cavity. When the resistance drops below the sensi-



tivity rating and a possible leak is detected, the output relay energizes and the LED illuminates to red. When the submersible pump seal fault condition is cleared, the output relay automatically resets. Units operate from a 120 VAC 50/60 Hz supply voltage.

The Model SPM 120AAA is ideal for OEM submersible pumps, potable or

wastewater sump pumps, industrial or municipal pump monitoring, control package manufacturing and general industrial leak detection. Units are UL Recognized and include a 10-year comprehensive product warranty.

For more information:

ATC Diversified Electronics
Phone: (304) 387-1200
www.marshbellofram.com



connect hardware components. Additionally, the 427D is easily integrated into the fieldbus level with built-in PROFIBUS DP/MPI or PROFINET (IRT, 3 PORTS; CP1616-compatible) and 2-Gigabit Ethernet (IE/PN) ports.

For more information:

Siemens Corporation
www.siemens.com



Providing Innovation for a Greener Tomorrow

Flexible speed solutions made easy!

Lafert's High Performance Permanent Magnet Motors are now in stock. Also available, are one of the most comprehensive and versatile lines of IEC motors and speed reducers. With over 50 years of proven performance, Lafert's power transmission products will let you push through even the most demanding applications.



Toll Free: 1.800.661.6413
Fax: 1.905.629.2852
www.lafertna.com
sales@lafertna.com



Copyright Lafert North America 2014. All rights reserved.

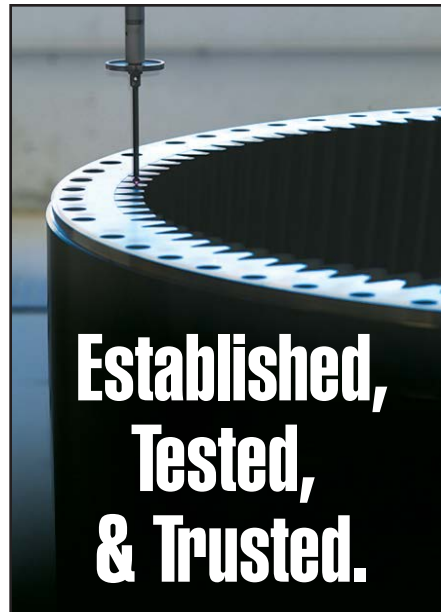

**Established,
Tested,
& Trusted.**



Using technology & innovation to meet your needs – now and into the future.

Brevini Gear:

Offers innovative solutions to complex geartrain challenges with state-of-the-art technologies in engineering, manufacturing and validation.

Focuses only on large, high-precision gears and gear related components.

Commits to meeting your technical, quality and delivery requirements for R&D, quality assurance, serial production or remanufacturing at a competitive price.

The Brevini Advantage

- AGMA Quality Level: 2015-1-A01 Grade 3
- Helical and spur gear capability: 12" (305 mm) to 68.10" (1730 mm)
- Helical and spur ring gear capability: 24" (600 mm) to 94.49" (2400 mm) OD
- In-house deep case, carburizing
- Design, assembly, and gear/gearbox validation

Brevini Gear

2400 N. Priority Way
Yorktown, IN 47396
765-759-2128
info@brevinigeared.com

brevinigeared.com



MotiCont

INTRODUCES HIGH SPEED, ZERO COGGING DDLMS

MotiCont, a manufacturer of motion control products, has introduced a new line of direct-drive linear motors (DDLMS).

MotiCont's DDLMS eliminate backlash and provide an economical solution for users requiring high acceleration, high speed, and long life. They are available in three off-the-shelf models.

The compact DDLM-019-044-01 linear motor is only 0.75 inches in diameter and 1.75 inches long. It has a stroke of 0.46 inches and features 11 ounces of continuous force and a 34.8 ounce peak. The compact, longer stroke DDLM-019-070-01 linear motor is also only 0.75 inches in diameter but is 2.75 inches long. It has a stroke of 0.96 inches and features 10.1 ounces of continuous force and a 32.1 ounce peak. For higher force applications the DDLM-038-051-01 linear motor is 1.5 inches in diameter and 2 inches long. It has a stroke of 0.375 inches with a continuous force of 3.1 pounds and a 9.9 pound peak.

These compact motors can be integrated into new and existing applications using threaded features on the front and rear faces of the motor, as well as each end of the shaft. The feed-

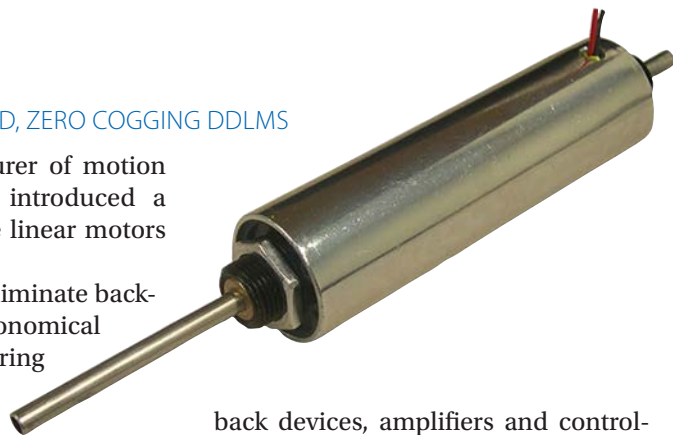

back devices, amplifiers and controllers are also available.

Non-commutated, moving magnet motors have zero cogging and the light mass of the moving part allows for high acceleration/deceleration for higher throughput, and direct coupling to the load increases accuracy. All DDLM linear motors are also available with internal springs to retract the shaft to a home position in the event of a sudden shutdown.

Typical DDLM direct drive motor applications include: Automated assembly, component insertion, fluid dispensing, pick-and-place, robotics, wafer handling, sorting, valve and flow control, labeling, tension control, and laser machining in the processing, manufacturing, medical, inspection, metrology and other industries.

For more information:

MotiCont
Phone: (818) 785-1800
www.moticont.com

GAM

RELEASES LINEAR MOUNT PRODUCTS BROCHURE

GAM, a manufacturer of precision gear reducers, servo couplings and linear mounting kits, announced the release of its new linear mount products brochure on Nov. 11.

GAM's linear mount products are a line of products designed to mount directly to actuators. This offering started with just a single item, the linear slide kit, after GAM noticed customers having difficulty mounting motors to actuators. Over the years, it has evolved into a complete range of gearboxes, couplings, and adapter kits. The product range expanded even further as GAM leveraged its manufacturing operations and engineering resources

to integrate individual products into complete system solutions as a service to customers.

"We really wanted to highlight our flexibility and capabilities beyond what customers may have known about or have seen in previous catalogs," said Craig Van den Avont, president of GAM. "This brochure really captures the essence of the level of value added service that we provide to our customer base."

For more information:

GAM
Phone: (847) 649-2530
Fax: (847) 649-2501
www.gamweb.com

Helix Linear Technologies

UNVEILS MINIATURE LINEAR GUIDANCE PRODUCTS

This new family of linear guidance products from Helix offers precision, accuracy and flexibility, and consists of an embedded inverse hook design. It's designed to tightly secure block components, which in turn helps them to better handle impact forces as they work to distribute stress over a larger area of the system.

Linear guidance systems offer accurate positioning, are often high speed and energy saving and can maintain accuracy for long periods of time in their respective applications.

Additional benefits of the Helix Miniature Linear Guides include:

Unique design: The miniature guides consist of a ball re-circulating design along with an embedded inverse hook design, which helps to reduce noise while at the same time extend life, re-

duce maintenance and improve high speed running capability.

Reinforced plates: The HMR-EE series stainless steel reinforced plates help to make this product line able to handle the operation of high running speeds.

Lubrication: Included in the design is an embedded lubrication pad, which works to oil balls and the raceway.

Greater surface contact: This feature allows the miniature guides to work with high load and high moment capacity when compared to competing products.

Dust-proof: Designed so that dust contamination is restricted, thereby enabling prolonged life.

For more information:

Helix Linear Technologies
Phone: (855) 435-4958
www.helixlinear.com

J.W. Winco

ANNOUNCES EN 450 BALL-SHAPED DOOR CATCHES

J.W. Winco, Inc., a supplier of standard industrial machine components, announced it now offers EN 450 ball-shaped door catches, in metric sizes.

These RoHS-compliant door catches were designed for use with both shutter doors and sliding doors. The ball-shaped door catch consists of a catch body to be fixed to a frame and a ball to be fixed to a door. The catch body is technopolymer plastic and matte black, and the ball is glass fiber reinforced plastic.

Under specific tests, the catch showed constant performances for more than 20,000 cycles.



Also available are EN 450.1 plastic spacers for ball-shaped door catches, made of glass fiber reinforced plastic. In addition to the basic spacing distances of 5, 10 and 15 millimeters, combinations of spacers can provide distances of 20, 25 and 30 millimeters as well.

J.W. Winco offers an extensive selection of inch and metric size adjustable levers, cabinet U-handles, plastic and steel hinges and locking mechanisms, revolving and retractable handles, hand wheels, hand cranks, tube connection and conveyor components, inch and metric construction tubing, shock absorption mounts, leveling mounts, hand knobs, spring, ball and indexing plungers, jig, fixture and fastening components, retaining magnet assemblies, toggle clamps, metric casters and wheels, universal joints, oil sight glasses, and metric tools for the industrial and commercial equipment industries.

For more information:

J.W. Winco, Inc.
Phone: 1 (800) 877-8351
www.jwwinco.com

DieQua offers more gearboxes

plus application experience to help select the best one for your needs

Helical Gearmotors



- 1-75 HP Capacity
- Motorized or Adapters
- Right Angle or Inline
- Shaft Mount Designs
- Multi-Stage Ratios
- Modular Design

Worm Reducers

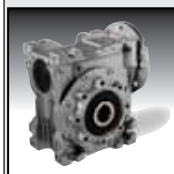

- 7 sizes, 28-110mm CD
- Fret-free Connection
- NEMA or IEC Adapters
- Coupling Input
- Aluminum Housings
- 2-Side Worm Support

Planetary Gearheads



- Precision or Economy
- Inline or Right Angle
- 40-155mm Frames
- Low Backlash
- 1 and 2 Stage Ratios
- Lubricated for Life

Servo Worm Gearheads

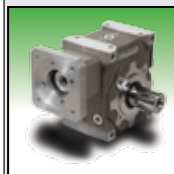

- 3 Backlash Levels
- Shafts or Hollow Bores
- Single or Dual Outputs
- 11 sizes, 25-200mm CD
- Capacity: 10-7000 Nm
- 20,000 Hour Ratings

Spiral Bevel Gearboxes

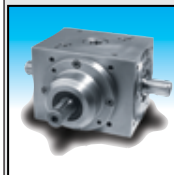

- 9 Sizes
- 1-250 HP Capacity
- Low Backlash Option
- Ratios from 1:1 to 6:1
- Output Shaft Options
- Machined Housings

Special Designs

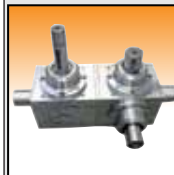

- Add-On Options
- Modified Dimensions
- High Speed Applications
- Special Environments
- Special Duty Needs
- Custom Designs

DIEQUA
Corporation
www.diequa.com
630-980-1133



See our complete product line!

Getting a Piece of that Sweet Coupling Pie

Success of oil and gas buoys industry in 'very, very good year'

Erik Schmidt, Assistant Editor

He was out.

Nine years ago, Ross Rivard left the coupling industry for the shimmering new world of luxury automotive components at Lacks Enterprises, where he was immediately enveloped by platinum trim systems and chrome composite wheels. It was glitz and glam and as sparkly clean as the fresh-from-the-dealership cars his products were embellished onto.

But for a self-proclaimed "shop rat" like Rivard, it was all a smidge too hoity-toity and entirely too hollow.

"I like to see how things work and what they do and how they come together," Rivard said. "The product [at Lacks] was shiny - but it didn't do anything. So I was kind of out of my element. It's a great company, really well run with wonderful products and they do very well in the marketplace. It just wasn't my thing."

So after nearly a decade removed from the industry, Rivard decided to return to his grime-covered roots earlier this year and get down and dirty with couplings once more. Turns out he couldn't have picked a better time.

"The industrial sector by itself is doing very well," Rivard said. "It continues to expand and the various sub-segments of the marketplace are doing very well, like energy and gas and oil. Others, like mining, are not doing as well. But overall it's doing very well."

"It was absolutely a good time to return."

Rivard, who became president of Ringfeder Power Transmission USA in Westwood, NJ back in April, moseys back into town as a prodigal son of sorts, both signifying and confirming the undeniable appeal of an industry that has enjoyed robust growth - most of all in 2014 - since his departure.

Fueling the Fire

Figuratively and literally speaking, oil and gas make most things in this world go - and in 2014 the coupling industry was of little exception.

Buoyed by an increased demand in fossil fuels over the past 12 months, the industry as a whole experienced one of its best calendar years in over a decade, according to Lovejoy (Downers Grove, IL) general manager Elliot Wilson.

"It was one of the best years [in a long time]," Wilson said. "Given the economic conditions we did not do a price increase this year, but we still saw significant growth. It was a very, very good year."

While companies remained tight-lipped and opaquely vague

For Related Articles Search

couplings

at www.powertransmission.com

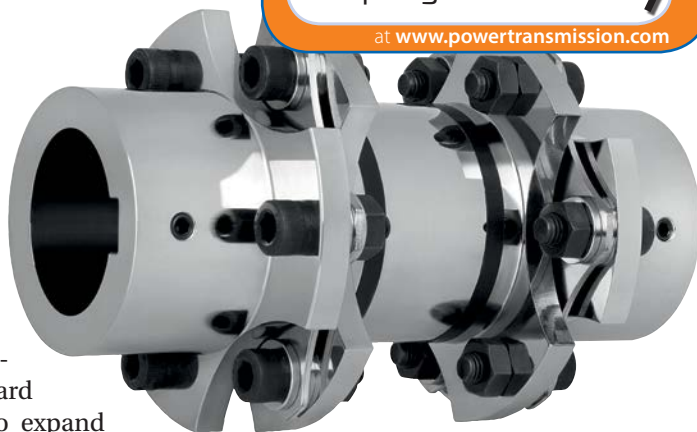

about specific empirical data and exactly *how good* 2014 was, the general consensus was simple: pretty darn.

"My understanding is that there was a very big demand for oil and gas extraction equipment," said Andy Lechner, sales manager of R+W America in Bensenville, IL. "There was kind of a boom over the last couple of years. It's been especially interesting for R+W here in the U.S. because Houston tends to be the technological center for the world when it comes to fossil fuels and petroleum. So a lot of the engineering and capital equipment gets made - if not in Houston - then somehow Houston tends to be involved in some way."

Of course, getting a piece of that sweet, oil and gas-soaked coupling pie wasn't as simple for a smaller, niche company like R+W as, say, a market power such as Lovejoy. The problem is the monolithic bulwark of carefully constructed guidelines and requirements imposed by the American Petroleum Institute (API) that date back to the 1940s.

As a producer of ATEX-certified, explosion-proof elastomer jaw couplings used on centrifugal pumps packages for over 10 years, R+W was already a player in the oil and gas industry in a limited capacity - but it didn't yet manufacture a product that met the regimented restrictions put forth by the API, and thus is stood on the outside looking in as other companies reaped the benefits of the world's newly accessible fuel extraction.

In mid-2013 Lechner and R+W had the opportunity - and the foresight - to



A production supervisor from KTR Corporation loads a large brake disc onto the vertical lathe machine.

EXPERIENCE



We recently came across a two decades old photo of some young up and coming engineers that were part of our drive engineering team at the time.

Guess what?

All those people are still with us. In fact, they are among our company leaders today.

Imagine. Twenty years of experience from each of them going to work for you every day. Incredible knowledge. Penetrating insights. Real results.

Yaskawa puts all of that to work for you every day. Think of what you can do with a partner like that.



**IT'S PERSONAL
YASKAWA**

**YASKAWA AMERICA, INC.
DRIVES & MOTION DIVISION
1-800-YASKAWA YASKAWA.COM**

Follow us:



For more info:
<http://Ez.com/yai701>





Ringfeder Power Transmission USA employee Jaime Fiorilo tests couplings.

expand their coupling offering by introducing its Survivor line of disc pack couplings.

“The (API) specifies that a certain, heavy-duty metallic coupling be used in pump drives – and that’s a disc pack coupling,” Lechner said. “There was an opportunity for R+W to expand its reach in the oil and gas market, and that was through the API version of the disc pack coupling. Our [disc pack coupling] uses a pure-friction drive to transfer the power. So we decided we had an opportunity to bring a technical advantage to that field, while at the same time expanding our offering.

“Out of those disc park couplings that R+W developed, one line called the LPA – which is especially intended for API610 pump systems – was made and marketed, and as we’ve gotten a little bit closer to the users of those couplings in the industry we’ve decided to work on a new series that incorporates some new features that we learned would be desirable for those engineers.

“We’re planning on rolling that product out in 2015.”

Like R+W, Michigan-based KTR Corporation decided to up its metaphorical ante in 2014 in order to fully tap into the thriving oil and gas marketplace.

“I think in general, and you’ll probably get the same response from everybody, is that [2014] was stronger than in years past,” said Chris Hatseras, KTR’s engineering and marketing manager. “Couplings service many different industries; you’re never in the same industry, so it’s just a mix of

different markets coming back up – oil and gas being one of them.”

Though Hatseras said that most of the new products KTR released in the United States over the past year were not technically designed to “spring-board” them off the swelling wave of oil and gas sales in 2014, the company did introduce the Rigiflex-HP – an

API-approved coupling used on turbo compressors, high-speed pump drives, generator drives and turbine drives – overseas in late 2013 specifically to capitalize on the oil and gas boom that carried over into last year.

KTR also released the ROTEX line of couplings with T-PUR improved polyurethane material, as well as the BoWex GT line, in 2014.

“These [products] were more complementary,” Hatseras said of the T-PUR and BoWex GT. “In some years we will introduce something that’s new. For instance, in oil and gas we introduced the [Rigiflex-HP] this year, but not in the U.S. So that’s an example of saying, ‘Here’s a new product, here’s a bunch of new sales and we’re really going to go after it.’ Typically, we’re a little more conservative on how we innovate.”

That last sentiment, though subtle, is a telling one. Even a company priding itself on conservatism, like KTR, found reason to exert itself beyond its normal means in 2014 – an irrefutable sign that

this past year was a grand one indeed, and also a grim revelation that perhaps 2015 won’t enjoy such fortuitousness.

“Oil and gas prices have gotten so low, how can there be a continuing need for this volume of capital equipment, like fuel pumps and so on?” Lechner asked rhetorically.

It’s a question that doesn’t have to be answered just yet, as most companies still seem to be riding high off the euphoric successes of 2014. Yet it’s out there, nonetheless – hovering ominously beyond the gilded sheen of cartoonish Scrooge McDuck money bags and vertical arrows exploding out the top of display charts.

“We think [the coupling industry] is going to be maybe not as strong in 2015 [as in 2014],” Hatseras said.

Reinventing the Wheel

One company that didn’t seem all that infatuated with the rampant rise of oil and gas, nor the (alleged) impending down year to come, was Lovejoy – a giant in the industry that seems to keep churning its massive legs no matter how flat or hilly the horizon.

“We saw an uptick [in 2014] pretty much across the board,” Wilson said. “There were industries that were down, like in the coal industry, but we were encouraged by seeing growth in multiple areas. It wasn’t really limited to just oil and gas.

“One thing about our company, probably more so than a lot of multinationals, is we are U.S.-centric. When you look at the global economy, the U.S. is doing really well right now. Our flexible coupling and our jaw couplings, these are products that go into a tremendous amount of industries;



Pictured are KTR Corporation’s ROTEX coupling and T-PUR spider products, released in 2014.

The First Name in Power Transmission



BALDOR • DODGE

Baldor • Dodge® power transmission products offer reliable service and low maintenance to help reduce your total cost of ownership. Our innovative bearings, gearing and power transmission products have solved the toughest applications for over 130 years.

Our technical sales team can help you with the most challenging applications, and our worldwide distributor network ensures immediate delivery.

When it comes to PT solutions, Baldor • Dodge is the first name in power transmission.

baldor.com 479-646-4711

- Unmatched Quality
- Superior Reliability
- Improved Uptime
- Quick Delivery
- American Made Since 1880

BALDOR

A MEMBER OF THE ABB GROUP



Download a QR reader app
and scan this code for
more information.
<http://qr2.it/Go/1031260>

they're multiuse couplings that go into everything from devices at home to factories all over the country - and those products were up solidly for us.

"So we saw strength universally across the country."

While several companies have recently come out with innovations specifically targeted towards hopping on the oil and gas bandwagon, Lovejoy - already firmly entrenched in the industry - spent 2014 stripping down the

wagon itself and completely reinventing the wheel, so to speak.

"We took a two-year deep-dive into trying to reinvent the gear coupling," Wilson said. "The gear coupling was created long, long before there was proper analysis and modern software. So we used countless optimization techniques and came up with the industry's best gear coupling..."

"...the HercuFlex is what we're calling it."

It's certainly an ambitious name for an ambitious product, and while it doesn't exactly conjure up images of a chiseled Greek demigod lambasting serpentine monsters with a heavy wooden club, the stout, platinum coupling is still a fairly Herculean engineering feat, according to Wilson.

"This is a truly new product," Wilson said. "This is a clean slate approach where we gave

our design engineers a blank canvas and said, 'look at everything out there and come up with what is absolutely the best gear coupling in the marketplace.'"

According to Wilson, the HercuFlex offers "increased torque and bore capacity, combined with a robust design that increases service life."

"There are a lot of people, and we're the same way, where you do little spins or little tweaks and call it a new product or innovation," Wilson said. "I can't tell you the last time the coupling industry saw a clean-slate, newly optimized solution. I've been in the industry five years and I'm not sure I've seen it."

Going Global ... and Beyond

In a loopy, roundabout way, this brings us back to Rivard and Ringfeder, who didn't revolutionize the world of couplings with any bold new products in 2014, but made one of the industry's most audible splashes nonetheless.

For Ringfeder, a global enterprise with a reach expanding from America's East Coast to the literal Far East of Ji-



Pictured are several products from R+W's EK line of elastomer couplings.



EXCEL GEAR, INC.

GEARS 1"-60" - AGMA 15

The **EXCEL** promise;

We'll excel where others fall short.

- Complete gear design, manufacturing and reverse engineering services
- Gear hobbing & grinding from 1"-60" (To AGMA 15)
- Internal gear grinding from 10"-60"
- Gear shaping to 36" diameter (9" face width)
- Wind turbine gear boxes, high speed spindles, gimbal heads and gear boxes
- Competitive prices and quality gear design and manufacturing with delivery commitments you can count on!

A TOTAL SERVICE COMPANY
ISO9001-2008 APPROVED

Introducing Excel-Lent Gear Design Software

providing accurate gear design and analysis that can get anyone up and running fast - www.excel-lentsoftware.com

815-623-3414

quotations@ExcelGear.com

www.ExcelGear.com



Ringfeder Power Transmission USA employee Wanda Boguslawski assembles a metal bellows coupling.

slightly in the rigid disc couplings. It allowed us to penetrate new markets where we had previously played on the fringe.”

And while Ringfeder sets its sights on broadening its global position in 2015, R+W has slightly loftier goals – goals that expand past the constrictions of man’s earthly domain and up towards the heavens.

“Our company is actually branching off into a number of other areas, including torque limiters and couplings for aerospace equipment,” Lechner said. “We’re working on projects for NASA... and we’re in the process of pursuing a certificate called AS90120, which is an aerospace-quality certification that we’re hoping to have wrapped up here in the next six months.

“I wish [I could tell you more], but I’m afraid it’s top secret stuff.”

angsu Province, China, the big news over the past 12 months was the acquisition of Tschan, a German-based producer and developer of shaft-coupling technology.

“It expanded our product line, giving us a full-complement,” Rivard said. “That’s the exciting thing for us.

“We acquired it in June of 2014, and what it did was expand our capability in the elastomer couplings and

So there it is – as 2014’s lucrative year comes to an end and companies look ahead to days and months that are likely to be less fruitful due to falling oil and gas prices, among other depressions, there remains reason for great optimism.

Couplings in space? It doesn’t get any more fulfilling than that.

Yeah, Rivard was right. He came back at the perfect time. **PTE**

For more information:

R+W America
(630) 521-0366
www.rw-america.com

Lovejoy, Inc.
(630) 852-0500
www.lovejoy-inc.com

Ringfeder Power Transmission
+49 (0)6078-9385-0
www.ringfeder.com

KTR Corporation
(219) 879-2792
www.ktr.com

**YOU THINK YOU'RE SO TOUGH?
MEET MY BROTHER.**

One of the most rugged, reliable gearmotors available today.

- High-grade grease standard helps to eliminate costly downtime
- Sealed for life – no refilling and level checks required
- Electrostat paint process delivers tough, chemically-resistant coating for the harshest operating environments
- 16 standard ratio options / 6 voltage options
- Experience and expertise – 10 million units produced in primary gearmotors facility over its 40 year history

Designed for reliability. Built for endurance.

brother
at your side

866.523.6283

BrotherGearmotors.com

The Small Motor Rule, How Will This Affect You?

New Federal Regulations Take Effect in March 2015

Chris Medinger



According to the Department of Energy (DOE), more than half of all electrical energy consumed in the U.S. is used by electric motors. To address this, several years ago, the DOE conducted a technical study as to what could be done to raise the efficiency levels of “small” motors. After years of study and litigation, the Small Motor Rule (SMR) was passed that covers two-digit NEMA frame single- and three-phase ¼ through 3 horsepower motors in open enclosures.

Facility managers are increasingly under pressure to reduce energy costs, increase productivity and reduce greenhouse gas emissions. To that end, this mandate is anticipated to have significant positive effects for products shipped from 2016–2045:

- Save approximately seven quads of energy (one quad is equivalent to the annual energy consumption of ten million U.S. households)
- Reduce \$41.4 billion in energy costs
- Cut 395 million metric tons of carbon dioxide emissions
- Eliminate the need for approximately eight new 250-megawatt (MW) power plants (Ref. 1)

The purchase price for an average motor makes up approximately three percent of the total lifecycle cost to own and operate. Energy costs make up the rest (Ref. 2). Managing motors

could pay big dividends in reducing energy costs and increasing process reliability.

But how will this mandate affect OEMs and end-users? Let’s examine the various aspects needed for complying with the new legislation taking effect March 9, 2015. Motors requiring outside agency approval, such as UL or CSA, have a two year extension and need to comply by March 9, 2017.

Motor Designs

One unique aspect about small electric motors is there are many design possibilities. Some motors’ designs employ magnets to assist with rotation and increase efficiency, while other designs, such as switch reluctance, are being improved with controls, making significant increases in efficiency. Older existing designs, such as shaded pole motors, may be phased out over time as they exhibit efficiencies much lower than new designs and products available. New motors require electronic control, increasing costs, but they have tremendous energy saving benefits (Ref. 3).

Tables 1 and 2 show the new minimum efficiency standard levels, which apply to all small electric motors manufactured for sale in the United States, or imported into the U.S. either as standalone items or as a part of a system (Ref. 4).

“Now, rising energy costs and the new legislation are moving efficiency to the top of everyone’s checklist.”

Who Is Affected?

Prior to this legislation, from an OEM designer’s point of view, motor choice focused primarily, in descending order, on price, size, noise-level, and weight. Until the Energy Independence and Security ACT (EISA) legislation, neither the OEMs nor their customers considered efficiency important enough to factor into a machine’s overall design. Now, rising energy costs and the new legislation are moving efficiency to the top of everyone’s checklist (Ref. 2).

End users will not have to replace machinery currently in use, but if they want to replace a motor in an existing machine, they may have to call the OEM to supply them with a motor that meets the most current regulations.

OEMs considering replacement of shaded pole or capacitor type motors with these new emerging designs will need to re-engineer their products and validate their motors. OEMs will incur costs to redesign their products to accommodate larger, more efficient motors, or to purchase a stockpile of replacement motors of the correct size.

Table 1 Standard levels for polyphase small electric motors

Motor Output Power	Six Poles	Four Poles	Two Poles
0.25 hp/0.18 kW	67.5	69.5	65.6
0.33 hp/0.25 kW	71.4	73.4	69.5
0.5 hp/0.37 kW	75.3	78.2	73.4
0.75 hp/0.55 kW	81.7	81.1	76.8
1 hp/0.75 kW	82.5	83.5	77.0
1.5 hp/1.1 kW	83.8	86.5	84.0
2 hp/1.5 kW	N/A	86.5	85.5
3 hp/2.2 kW	N/A	86.9	85.5

*Standard levels are expressed in terms of full-load efficiency

Table 2 Standard levels for capacitor-start induction-run and capacitor-start capacitor-run small electric motors.

Motor Output Power	Six Poles	Four Poles	Two Poles
0.25 hp/0.18 kW	62.2	68.5	66.6
0.33 hp/0.25 kW	66.6	72.4	70.5
0.5 hp/0.37 kW	76.2	76.2	72.4
0.75 hp/0.55 kW	80.2	81.8	76.2
1 hp/0.75 kW	81.1	82.6	80.4
1.5 hp/1.1 kW	N/A	83.8	81.5
2 hp/1.5 kW	N/A	84.5	82.9
3 hp/2.2 kW	N/A	N/A	84.1

*Standard levels are expressed in terms of full-load efficiency

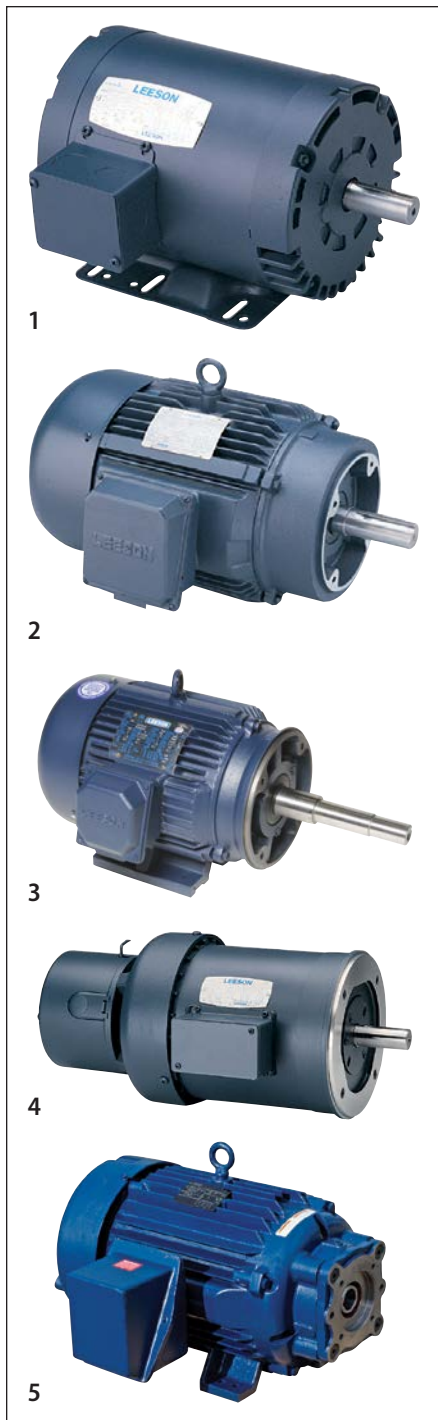

Do you use motors like these? You may soon be affected by the Small Motor Rule, which goes into effect March 9, 2015. Shown here are just some of the motor types that will be affected, including: 1) three-phase ODP motors, designed for air compressor, pump, fan and blower duty applications; 2) three-phase C-Face motors used on pumps, compressors, blowers, fans and other industrial applications; 3) NEMA JP pump motors, used in continuous-duty applications where the pump impeller is mounted directly on the motor shaft; 4) brake motors, used in conveyors, hoists and packaging equipment; and 5) hydraulic SAE pump motors, used in oilfield applications and the hydraulic pump industry.

The proposed rules cover capacitor design motors as described, which impact many different types of OEMs, such as appliance manufacturers, pool pumps, and residential and commercial HVAC equipment.

To comply with the new regulations, motor manufacturers will need to change original motor designs significantly. Since additional active materials, like copper and steel, will be needed in motor designs to increase efficiency, the overall cost of motors

will likely increase. Additionally, manufacturers will face the tooling cost for each separate design at each incremental efficiency level. Besides these capital expenditures, manufacturers will incur equipment conversion expenses such as research and development, testing, and product literature development associated with the new energy conservation standards. The DOE admits that the rule “may require expenditures of \$100 million or more on the private sector...” (Ref. 5).



www.circlegear.com

Circle Gear and Machine

1501 South 55th Ct. • Cicero, IL 60804
Ph: 708-652-1000 • Fax: 708-652-1100

WE'RE EXPANDING!



EQUIPMENT PURCHASES

- Luren LFG-8040 Verticle Gear Profile Grinder
- Gleason 463 spiral/hypoid gear tooth grinder

FACILITY

- Purchased 77,000 sq ft building, expanding to 122,000 sq ft

STRATEGIC PLANS

- Continued growth in spiral bevel/hypoid marketplace
- Expand gearbox service and overhaul business



GEARBOX REPAIR SPECIALISTS

- Prompt, accurate quotations
- Competitive pricing
- Quality repairs/rebuilds

Quality Reducer Service

1501 South 55th Ct. ■ Cicero, IL 60804
708-354-8080 | FAX: 708-652-1133

WE SERVICE ALL TYPES OF INDUSTRIAL GEARBOXES

www.qualityreducer.com

"To comply with the new regulations, motor manufacturers will need to change original motor designs significantly."

The good news for end users at all levels is these regulations will result in reduced energy consumption. End users have no direct compliance requirements with the DOE like motor manufacturers and OEMs. They do not need to concern themselves with equipment design issues related to motor changes nor do they need to submit compliance paperwork to the DOE.

Trouble finding stainless rings?

Spirolox® Retaining Rings: 6,000 Stock Sizes In 302 & 316 Stainless Steel

Spirolox Retaining Rings, Exclusively From Smalley



*Free Samples
Free CAD Models*

Compatible with stamped ring grooves

No Ears To Interfere® with the assembly

Stocked from 1/4" to 16" diameters

No-Tooling-Costs™ on specials; .200" to 120"



Smalley®
Steel Ring Company

847.719.5900 • info@smalley.com



Find out why to use Smalley stainless rings at: www.smalley.com/stainless

A Change in Topology

To meet these higher efficiency levels, many motors will change in topology. Based on meeting higher efficiency levels there may be potential impact on the mounting and alignment.

The Nuts and Bolts (SMR & EISA Expansion)

In May 2014, the DOE released communications with required expansions of three-phase, single-speed, low voltage, integral HP motors, 1-500 HP to meet NEMA Premium efficiency levels, excluding some exceptions. This ruling, which goes into effect on June 1, 2016, expands current motor regulation for motors that were not previously covered in the EISA 2010 regulations. These families of motors are also listed below.

For the SMR, the motors that are in scope include:

- 2-digit frame numbers - 42, 48 and 56 frame motors and their IEC equivalent frame size motors
- The Speed or Poles of the motors would include 2, 4 and 6 pole designs from 1/4 to 3 HP
- Open construction motors that are either 3 phase (Polyphase), Cap Start- Induction Run or Cap Start/ Cap Run designs
- Continuous duty rated and also meet NEMA Service Factor

Exemptions to this rule include:

- Definite or Special Purpose OPEN construction design motors
- Motor speeds that are outside of the 2, 4 and 6-pole speeds
- Enclosed motors
- Motor types that are not classified as being three-phase, cap start-induction run or cap start/cap run
- Intermittent duty motors as well as designs outside the HP and frame size listing as described above
- Motors that are already covered by other efficiency legislation are also not covered by this rule

The Energy Independence and Security Act (EISA) expansion and compliance rule, sometimes referred to as the EISA Expansion Rule, expands the following list of motor designs to meet NEMA Premium efficiency. 1 - 500 HP, NEMA Design A, B & C (1-200 HP only today for Design A & B motors); IEC Design N, H, 8 Pole designs, enclosed

56 Frame IHP (1 HP and larger) that are either of General Purpose, Special or Definite Purpose design electric motors.

The Efficiency levels must meet NEMA Premium levels as listed in Table 12-12 (IE3 – 60Hz).

Motors that are now affected by this Expansion Rule include:

- NEMA Design A & B motors from 201 to 500HP
- NEMA Design C motors from 1 to 500 HP
- All voltages ≤ 600 volts
- 8-pole motors
- Electric motors with non-standard endshields, flanges or shafts
- Motors with moisture resistant windings, like encapsulated or sealed windings
- Motors that use any non-standard mounting like a base or cradle
- Motors that do not have a base or cradle – footless designs
- Partial designed electric motors - but not rotor and stator sets
- Vertical hollow shaft motors
- TENV designed motors
- JM and JP Pump motors
- Electric motors having thrust or roller bearings
- Integral brake motors
- Motors with separately cooled blowers on them
- Enclosed 56 frame 1HP and larger – 56 Open motors are covered by the SMR
- Gearmotors if the motor can be removed from the reducer and work as independent motor

Exempt Motors from the 2010 Expansion Rule include:

- Fire Pump motors
- Liquid cooled motors
- Submersible motors
- Air over design motors
- Component sets (stator, rotor sets)
- Small electric motors below 56 frame – See SMR Rules
- Advanced Motor Technology motors which include PMAC, ECM, Brushless DC, etc.
- Inverter Duty only motors

For Related Articles Search

efficiency

at www.powertransmission.com

Conclusion

The electric motor is a critical component in many plant applications and in most equipment and is used in a wide range of equipment in almost every sector of the economy. Given this, the impact of this regulation will be significant for overall energy consumption in the United States. **PTE**

References

1. www.federalregister.gov/articles/2010/03/09/2010-4358/energy-conservation-program-energy-conservation-standards-for-small-electric-motors#h-11 (accessed September 4, 2014).
2. Kitt Butler, "What Motor Users Need to Know," InTech Magazine, November 2009.
3. "Electric Motor Efficiency Regulations: What Motor Manufacturers, OEMs, and Motor Users Need To Know," *techbriefs.com*, March 2, 2010.
4. Kitt Butler and David Berkowitz, "Electric Motor Efficiency Regulations, Part Two," *Pumps and Systems*, July 10, 2010.
5. www.americanactionforum.org/regulation-review/energy-efficiency-standards-for-commercial-and-industrial-electric-motors (accessed September 5, 2014).

Chris Medinger is product marketing specialist with LEESON Electric and may be reached at (262) 387-5410 or chris.medinger@leeson.com. LEESON is a Regal brand located in Grafton, WI. Regal Beloit Corporation (NYSE:RBC) is a leading manufacturer of electric motors, mechanical and electrical motion controls and power generation products serving markets throughout the world. Regal is headquartered in Beloit, Wisconsin, and has manufacturing, sales and service facilities throughout the United States, Canada, Mexico, Europe and Asia. Regal's common stock is a component of the S&P Mid Cap 400 Index and the Russell 2000 Index.



**McINNES
ROLLED RINGS**

**WHEN WEEKS ARE
JUST TOO LONG...**

WE SHIP IN AS FEW AS 5 DAYS

By combining the latest in ring rolling technology with experienced people, McInnes delivers the best value in carbon, alloy and stainless steel rolled rings.



**CARBON · ALLOY
STAINLESS STEEL
RINGS · 4" - 144" OD**

www.McInnesRolledRings.com

1.800.569.1420

2014 PTE Buyers Guide

About This Directory

The 2014 *Power Transmission Engineering Buyers Guide* was compiled to provide you with a handy resource containing the contact information for significant suppliers of power transmission components.

Accessories..... Page 28
 Actuators Page 29
 Adjustable Speed Drives Page 30
 Bearings Page 32
 Belts & Belt Drives..... Page 34
 Brakes Page 35
 Chain & Chain Drives Page 36
 Clutches..... Page 36
 Controls..... Page 38
 Couplings and U-Joints Page 39
 Fluid Power..... Page 41
 Gear Drives Page 41
 Gear Manufacturing Services..... Page 42
 Gears Page 43
 Industrial Hardware and Machine Parts Page 45
 Linear Motion Devices Page 45
 Lubrication Page 46
 Motors..... Page 46
 Resources Page 47
 Seals..... Page 47
 Sensors..... Page 47
 Software..... Page 47
 A to Z Company Index..... Page 48

Bold Listings throughout the Buyers Guide indicate that a company has an advertisement in this issue of *Power Transmission Engineering*.

How to Get Listed in the Buyers Guide

Although every effort has been made to ensure that this Buyers Guide is as comprehensive, complete and accurate as possible, some companies may have been inadvertently omitted. If you'd like to add your company to the directory, we welcome you. Please visit www.powertransmission.com/getlisted.php to fill out a short form with your company information and Buyers Guide categories. These listings will appear online at www.powertransmission.com, and those listed online will automatically appear in next year's printed Buyers Guide.

Handy Online Resources

The *Power Transmission Engineering Buyers Guide* – The listings printed here are just the basics. Visit our online buyers guide for the most comprehensive directory of suppliers of gears, bearings, motors, clutches, couplings, gear drives and other mechanical power transmission components, broken down into sub-category by type of product manufactured:

www.powertransmission.com/directory/



The *Gear Industry Buyers Guide* – If you manufacture gears or need information on suppliers of machine tools, tooling and services for gear manufacturers, please visit the buyers guide on *Gear Technology's* website:

www.geartechnology.com/dir/

ACCESSORIES

ABL Products Incorporated
 AGI Automation Components
 AISCO Industrial Couplings
 ASI Technologies Inc.
 AST Bearings
 Accent Bearings Co. Inc.
 Ace World Companies
 Acorn Industrial Services
 Advanced Test & Automation Inc.
 Aerotech Inc.
 Akron Gear and Engineering
 All Metric Small Parts (aMsp)
 Amacoil, Inc.
 American Collars & Couplings, inc.
 American Plastics Depot
 Ameridrives Power Transmission
 Ametric / American Metric Corporation
 Area Distributors Inc.
 Ascent Precision Gear Corporation
 Ashutosh Power TransBelts Limited
 Atlanta Drive Systems Inc.
 Autoparts Solutions PvtLtd
 Axu S.r.l.
 B&B Manufacturing, Inc.
 BDI - Bearing Distributors Inc.
 BRECOflex CO., L.L.C.

Baldor Electric Company

5711 R.S. BOREHAM, JR. ST.
 P.O. BOX 2400
 FORT SMITH, AR 72901
 Phone: (479) 646-4711
 Fax: (479) 648-5792
www.baldor.com

SEE OUR AD
P21

Bearing Service Company
 Bearings Limited
 Beijing THC Limited
 Belcon Engineers P. Ltd.
 BellowsTech, LLC
 Best Parts Online
 Bevel Gears India Pvt. Ltd.
 Bibby Transmissions
 Bishop-Wisecarver Corp.
 Brevini Power Transmission - Canada
 Brewer Machine & Gear Co.
 CENTA Corp.
 CMS Vibration Solutions Ltd
 Calicut Engineering Works Limited
 Certified Reducer Rebuilders Inc
 Challenge Power Transmission (Aust) Pty Ltd
 Challenge Power Transmission PLC
 Collars and Coupling
 ComInTec Srl
 Conroll Corporation
 Core Supply LLC
 Cortec Corporation
 Cross + Morse
 Currie Enterprises
 Custom Gear & Machine Inc.
 Custom Machine & Tool Co. Inc.
 Cyclo-Index
 Daido Corporation of America
 Dalton Bearing Service, Inc.
 Danaher Motion and Thomson
 Darbar Belting
 Datasyst Engineering & Testing Services, Inc.
 Daubert Cromwell LLC
 Davall Gears Ltd.
 Del-Tron Precision Inc.
 Desch Canada Ltd.

Designatronics, Inc.

2101 JERICHO TURNPIKE, NEW HYDE PARK, NY 11040
 Phone: (516) 328-3300
 Fax: (516) 326-8827
info@designatronics.com
www.designatronics.com

SEE OUR AD
 BACK COVER
**P34, 35,
 40, 42, 45**

Dn Sales Australia
 Drive Components LLC
 Drive Systems Technology Inc.
 Electro Steel Engineering Company
 Emerson Industrial Automation - Drives & Motor
 Emerson Power Transmission
 Equipment Concepts
 Fife Corporation
 Framo Morat Inc.
 GMB Associates
 Gajra Gears Pvt. Ltd.
 Gates Corporation
 Gayatri Gear Industries
 Gear Master Inc.
 Gleason K2 Plastics
 Great Northern Products Inc.
 HBM
 HEIDENHAIN Corporation
 Hangzhou Xingda Machinery Co. Ltd.
 Hayes Manufacturing Inc.
 Henan Contrust Gear Transmission Co., Ltd.
 Hi-Grade Inc.
 Hydraulic Problems ?, Inc.
 IBT, Inc

IDC-USA

933 WESTERN DRIVE, INDIANAPOLIS, IN 46241
 Phone: (317) 244-9200
 Fax: (317) 244-4600
sswaim@idc-usa.com
www.IDC-USA.com

SEE OUR AD
P29

ITW Heartland
 Industrial Jig & Fixture
 Industrial Pulley & Machine Co, Inc.
 Intech Corporation
 Intellidrives, Inc
 International Distribution Alliance, Inc. (IDA, In
 JVL Industri Elektronik A/S
 Jason Industrial Inc.
 K+S Services

KTR Corporation

122 ANCHOR ROAD, MICHIGAN CITY, IN 46360
 Phone: (219) 872-9100
 Fax: (219) 872-9150
ktr-us@ktr.com
www.ktr.com

SEE OUR AD
P39, 40

Kamar Industries
 Kbk Antriebstechnik Gmbh
 Kinefac Corporation
 Kluber Lubrication North America L.P.
 LM76 Linear Motion Bearings
 Lovejoy, Inc.
 MGT - Magnetic Gearing & Turbine Corp.
 MMB Bearing Co. Inc.
 MROSupply
 MT Tool & Manufacturing
 Magnum Manufacturing
 Magtrol, Inc.
 Maguire Technologies

Martin Sprocket & Gear

3100 SPROCKET DRIVE, ARLINGTON, TX 76015
 Phone: (817) 258-3000
 Fax: (817) 258-3333
mail@martinsprocket.com
www.martinsprocket.com

SEE OUR AD
P31

Maurey Manufacturing Corporation

Micronor Inc.
 Ming Chang Traffic Parts Mfg.
 Mini-Broach Machine Company
 Minsk Gear Works
 Motion Industries
 Moventas Ltd.
 NDE Power Transmissions
 Netshape Technologies, Inc.
 New England Belting Company
 North American Clutch Corp. (noram)
 Norwin Electronics Limited
 Novotec Argentina SRL
 Onvio LLC
 Orttch
 PI (Physik Instrumente) L.P. Piezo Actuator Nano
 PIC Design
 PT Outlet: Power Transmission Distributors
 Paul's Transmission Shenzhen Co.,Ltd
 Peer Bearing Company
 Pix Europe Limited
 Pix Transmissions Limited
 Plastock - Putnam Precision Molding, Inc.
 Popular Mechanical Works
 Potomac Electric
 Power Transmission Engineers
 Powermach Import & Export Co.,Ltd
 Pulley Manufacturers International Inc.

QA1 Precision Products

21730 HANOVER AVE, LAKEVILLE, MN 55044
 Phone: (800) 721-7761
 Fax: (952) 985-5679
 sales@qa1.net
 www.qa1.net/industrial

SEE OUR AD
P2**Quality Transmission Components**

RGW Sales Canada
 RUBENA a.s.
 Rathpolybond Pty Ltd.
 René Baer AG
 Resistoflex Private Limited
 Ringball Corporation
 Ringspann Corporation
 Ritbearing Corp.
 Rockwell Automation
 Romax Technology Limited
 Rotor Clip Company, Inc.
 Rowland Co., The

SEW-Eurodrive

1295 OLD SPARTANBURG HWY., LYMAN, SC 29635
 Phone: (864) 439-7537
 Fax: (864) 439-7830
 www.seweurodrive.com

SEE OUR AD
INSIDE BACK COVER**SIPCO-MLS****SKF USA Inc.**

890 FORTY FOOT ROAD, LANSDALE, PA 19446
 Phone: (267) 436-6000
 www.skf.com

SEE OUR AD
P3**SKG Enterprises**

Schenck Trebel Corporation
 Smart Manufacturing Technology - SMT
 Specialty Motions, Inc.
 Spn Schwaben Praezision
 Sprockets Australia Pty. Ltd.
 Stearns Division / Rexnord Industries Inc.
 Steelmans Broaches Pvt Ltd
 Steinmeyer Inc.

Sterling Instrument

2101 JERICHO TURNPIKE, NEW HYDE PARK, NY 11040
 Phone: (516) 328-3300
 Fax: (516) 326-8827
 sdp-sisupport@sdp-si.com
 www.sdp-si.com

SEE OUR AD
BACK COVER
P42,45**Stock Drive Products**

2101 JERICHO TURNPIKE, NEW HYDE PARK, NY 11040
 Phone: (516) 328-3300
 Fax: (516) 326-8827
 sdp-sisupport@sdp-si.com
 www.sdp-si.com

SEE OUR AD
BACK COVER
P35,40

Sumitomo Machinery Corp. of America
 T.E.A. Machine Components
 TSS Rotterdam B.V.
 Taiwan Precision Gear Corp.
 Tapeswitch Corporation
 Team Industries
 Technico
 Tef - Cap Industries
 Test Equipment Connection
 Tool Masters India
 Torque Transmission
 Transply Inc.
 Tristate Bearing & Supply Co. Inc.
 Trojon Gear Inc.
 Tsubaki of Canada Limited
 V2 Engineering Systems
 VCST LP
 VL Motion Systems Inc.

Vision Quality Components, Inc
 WD Bearing America
 WMH Transmissions Ltd
 Warner Linear
 Whittet-Higgins Company

Worldwide Electric Corp.

1 GROVE ST. #201B
 PITTSFORD, NY 14534
 Phone: (800) 808-2131
 Fax: (800) 711-1616
 www.worldwideelectric.net

SEE OUR AD
P34

Wyko - London & Overseas Supplies
 Zerelli Technologies Inc
 pylon Gears (Pty) Ltd

ACTUATORS

AGI Automation Components
 Acme Gear Co.



**DAY & NIGHT
 WE WORK HARD FOR YOU**

IDC-USA[®]

Your IDC Distributor is on call
 with the products & expertise you need



WWW.IDC-USA.COOP / DIFFERENCE

Acorn Industrial Services
 Aerotech Inc.
 Agro Engineers
 Akgears, LLC
 Amacoil, Inc.
 Ametric / American Metric Corporation
 Anaheim Automation, Inc.
 Atlanta Drive Systems Inc.
 Avion Technologies Inc.
 BDI - Bearing Distributors Inc.
 Bearings and Industrial Supply Co., Inc.
 Beaver Aerospace and Defense Inc.
 Befared
 BellowsTech, LLC
 Bevel Gears India Pvt. Ltd.
 Bharat Gears Ltd.
 Bishop-Wisecarver Corp.
 Buehler Motor, Inc.
 Calicut Engineering Works Limited
 Central Gear & Machine
 Certified Reducer Rebuilders Inc
 Control Switches International Inc (csii)
 Core Supply LLC
 Curtis Machine Co. Inc.
 Custom Sensors & Technologies
 Dalton Bearing Service, Inc.
 Danaher Motion and Thomson
 Del-Tron Precision Inc.

Designatronics, Inc.

2101 JERICHO TURNPIKE, NEW HYDE PARK, NY 11040

Phone: (516) 328-3300

Fax: (516) 326-8827

info@designatronics.com

www.designatronics.com

SEE OUR AD
BACK COVER
P 34, 35,
40, 42, 45

Discovery Technology International, Inc.
 Dn Sales Australia
 Drive Lines Technologies Ltd
 Duff Norton Australia
 Dunkermotoren USA Inc.
 Dynamic Structures and Materials, LLC
 Emerson Industrial Automation - Drives & Motor
 Exlar Corporation
 FMC Engineering
 Festo Corporation
 Fife Corporation
 Framo Morat Inc.
 Gil Equipamentos Industriais Ltda.
 Gleason K2 Plastics
 Hallmark Industries Inc.
 Houston Pump and Gear
 IAI America, Inc.
 IBT, Inc

IDC-USA

933 WESTERN DRIVE, INDIANAPOLIS, IN 46241

Phone: (317) 244-9200

Fax: (317) 244-4600

sswaim@idc-usa.com

www.IDC-USA.com

SEE OUR AD
P 29

ITW Heartland
 Industrial Clutch Parts Ltd.
 Intellidrives, Inc
 K+S Services
 Kamar Industries
 LYC North America Inc
 Lab Threads & Gear Works, Inc.
 MROSupply
 Mavilor Motors, S.a.
 Midwest Motion Products
 Motion Industries
 Ngt Specialty Valves
 Niebuhr Gears

Ningbo Zhongyi Hydraulic Motor Co. Ltd.

NINGBO ZHENHAI ECONOMIC DEVELOPMENT ZONE

ROAD 88, ITALY

NINGBO

CHINA

Phone: +(86) 574-86261172-800

Fax: +(86) 574-86288064

sales@zihyd.com

www.zihyd.com

SEE OUR AD
P 33

North American Clutch Corp. (noram)
 Norwin Electronics Limited
 Novotec Argentina SRL
 PI (Physik Instrumente) L.P. Piezo Actuator Nano
 PTD Outlet: Power Transmission Distributors
 Parker Hannifin Electromechanical Automation Divis
 Performance Gear Systems, Inc.
 Popular Mechanical Works
 Portescap
 Potomac Electric
 Precipart
 Precision Screw Thread
 RGW Sales Canada
 Rex Engineering Corp.
 Ringball Corporation
 Rockwell Automation
 Rowland Co., The
 S.M. Shah & Company

SEW-Eurodrive

1295 OLD SPARTANBURG HWY., LYMAN, SC 29635

Phone: (864) 439-7537

Fax: (864) 439-7830

www.seweurodrive.com

SEE OUR AD
INSIDE BACK COVER**SIPCO-MLS****SKF USA Inc.**

890 FORTY FOOT ROAD, LANSDALE, PA 19446

Phone: (267) 436-6000

www.skf.com

SEE OUR AD
P 3**Sallex Machine Tools****Schaeffler Group USA, Inc**

308 SPRINGHILL FARM ROAD

FORT MILL, SC 29715

Phone: (803) 548-8500

Fax: (803) 548-8599

www.schaeffler.us

SEE OUR AD
P 7

Schneider Electric Motion Competency Center
 Serapid Inc.
 Servometer
 Sesame Motor Corp.
 Specialty Motions, Inc.
 Spn Schwaben Praezision
 Steinmeyer Inc.

Sterling Instrument

2101 JERICHO TURNPIKE, NEW HYDE PARK, NY 11040

Phone: (516) 328-3300

Fax: (516) 326-8827

sdp-sisupport@sdp-si.com

www.sdp-si.com

SEE OUR AD
BACK COVER
P 42, 45

T.E.A. Machine Components
 Technico
 Tolomatic, Inc.
 VL Motion Systems Inc.
 WEG
 Warner Linear
 Wittenstein (formerly alpha gear drives)
 Wyko - London & Overseas Supplies

ADJUSTABLE SPEED DRIVES

AISCO Industrial Couplings
 ASI Technologies Inc.
 Ace World Companies
 Acme Gear Co.
 Acorn Industrial Services
 Aerotech Inc.
 Agro Engineers
 Akgears, LLC
 Allied Motion
 Amacoil, Inc.

Ametric / American Metric Corporation
 Andantex USA Inc.
 Area Distributors Inc.
 Atlanta Gear Works, Inc

Automation Direct

3505 HUTCHINSON ROAD, CUMMING, GA 30040

Phone: (800) 633-0405

Fax: (770) 844-4212

sales@automationdirect.com

www.automationdirect.com

SEE OUR AD
INSIDE FRONT COVER

B&B Manufacturing, Inc.
 BDI - Bearing Distributors Inc.

Baldor Electric Company

5711 R.S. BOREHAM, JR. ST.

P.O. BOX 2400

FORT SMITH, AR 72901

Phone: (479) 646-4711

Fax: (479) 648-5792

www.baldor.com

SEE OUR AD
P 21

Bearing Service Company
 Beaver Aerospace and Defense Inc.
 Bevel Gears India Pvt. Ltd.
 Bison Gear and Engineering Corp.
 Bonfiglioli Riduttori S.p.A.
 Bonfiglioli USA
 Boston Gear
 Brevini Power Transmission - Canada
 Brevini USA
 Brewer Machine & Gear Co.
 Buehler Motor, Inc.
 Calicut Engineering Works Limited
 Carlisle Power Transmission
 Carlyle Johnson Machine Co. LLC, The
 Central Gear & Machine
 Certified Reducer Rebuilders Inc
 Challenge Power Transmission PLC
 Cleveland Gear Co.
 Conroll Corporation
 Custom Motors Inc.
 Cutes Corporation
 D&D Intl. Corp.
 Dalton Bearing Service, Inc.
 Danaher Motion and Thomson
 Davall Gears Ltd.
 Duff Norton Australia
 Dunkermotoren USA Inc.
 Dynex/Rivett Inc.
 Electronic Machine Parts
 Emerson Industrial Automation - Drives & Motor
 Essential Power Transmission Pvt. Ltd.
 FMC Engineering
 Fairchild Industrial Products Co.
 Festo Corporation
 GMB Associates
 Gayatri Gear Industries
 Gil Equipamentos Industriais Ltda.
 HPB Motion Control Co. Ltd.
 Hoffmann Technics Ag
 Houston Pump and Gear
 IBT, Inc

IDC-USA

933 WESTERN DRIVE, INDIANAPOLIS, IN 46241

Phone: (317) 244-9200

Fax: (317) 244-4600

sswaim@idc-usa.com

www.IDC-USA.com

SEE OUR AD
P 29

Intellidrives, Inc
 K+S Services
 KB Controls
 LEESON Electric

Lafert North America

5620 KENNEDY RD.

MISSISSAUGA ON L4Z 2A9

CANADA

Phone: (905) 629-1939 or toll free (800) 661-6413

Fax: (905) 629-2852

ptsales@lafertna.com

www.lafertna.com

SEE OUR AD
P 15

Martin

Flexible Couplings



Jaw Couplings

- No lubrication
- Easy installation
- No metal-to-metal contact
- Oil, dirt, sand, moisture, grease resistant
- Easy inspection of load carrying element (spider)
- Flexibility of angular or parallel misalignment of shafts by Buna-N element permits smooth power transmission
- Two styles of **Jaw Couplings** available:
 - *Martin Super (MS)*, for higher horsepower
 - *Martin Universal (ML)*, completely interchangeable



QUADRA-FLEX®

This couplings come in a variety of styles and designs to meet specific customer needs. These styles include flanges and sleeves of various types and materials. The total product line includes 13 sizes varying in torque ratings up to 72,000 in-lb.

The sleeves are available in 4 different compounds:

- **TPR** (Types JEM, JEMS, EM)
- **EPDM** (Type E)
- **Neoprene** (Type N)
- **Hytrel®** (Type H & HS)



Martin SPROCKET & GEAR, INC.

www.martinsprocket.com • 817-258-3000



Marshall Wolf Automation Inc.
 Maurey Manufacturing Corporation
 Mavilor Motors, S.a.
 Mitsubishi Electric Automation, Inc.
 Motion Industries
 NAC Harmonic Drive
 New Power Electric (USA) LLC
 Norwin Electronics Limited
 Novotec Argentina SRL
 PI (Physik Instrumente) L.P. Piezo Actuator Nano
 PTD Outlet: Power Transmission Distributors
 Parker Hannifin - SSD Drives Div.
 Performance Gear Systems, Inc.
 Phyttron, Inc.
 Potomac Electric
 Precipart
 René Baer AG
 Rockwell Automation
 S.M. Shah & Company

SEW-Eurodrive

1295 OLD SPARTANBURG HWY., LYMAN, SC 29635
 Phone: (864) 439-7537
 Fax: (864) 439-7830
www.seweurodrive.com

SEE OUR AD
INSIDE BACK COVER

Sallex Machine Tools
 Schneider Electric Motion Competency Center
 Serapid Inc.
 Siemens Energy & Automation
 Siemens Industry, Inc.
 Siti Spa Riduttori
 Specialty Motions, Inc.
 Sprockets Australia Pty. Ltd.

Sterling Instrument

2101 JERICHO TURNPIKE, NEW HYDE PARK, NY 11040
 Phone: (516) 328-3300
 Fax: (516) 326-8827
sdp-sisupport@sdp-si.com
www.sdp-si.com

SEE OUR AD
BACK COVER
P42,45

Stober Drives, Inc.
 Suzhou Asia Pacific Metal Co., Ltd.
 TB Wood's
 TVT America, Inc.
 Taiwan Precision Gear Corp.
 Team Industries
 Teco Westinghouse
 Tolomatic, Inc.
 Transply Inc.
 Tristate Bearing & Supply Co. Inc.
 VL Motion Systems Inc.
 Var-Spe Variatori Oleodinamici
 Vision International
 WEG

Worldwide Electric Corp.

1 GROVE ST. #201B
 PITTSFORD, NY 14534
 Phone: (800) 808-2131
 Fax: (800) 711-1616
www.worldwideelectric.net

SEE OUR AD
P34

Wyko - London & Overseas Supplies
 Xuzhou BeiLai Engineering Machinery Co., Ltd
 Zero-Max

BEARINGS

AST Bearings
 Accent Bearings Co. Inc.
 Acorn Industrial Services
 Aerotech Inc.
 American Plastics Depot
 American Swiss Products Co., Inc.
 Ametric / American Metric Corporation
 Area Distributors Inc.
 B&B Manufacturing, Inc.
 BDI - Bearing Distributors Inc.
 Baker Bearing Company

Baldor Electric Company

5711 R.S. BOREHAM, JR. ST.
 P.O. BOX 2400
 FORT SMITH, AR 72901
 Phone: (479) 646-4711
 Fax: (479) 648-5792
www.baldor.com

SEE OUR AD
P21

Barrel Service Company
 Bearing Service Company
 Bearings Limited
 Beijing THC Limited
 Bently Pressurized Bearing Co.
 Bishop-Wisecarver Corp.
 Bison Gear and Engineering Corp.
 Boca Bearing Company
 Boston Gear
 Brewer Machine & Gear Co.

C&U Americas, LLC

45901 FIVE MILE ROAD
 PLYMOUTH, MI 48170
 Phone: (734) 656-0260
 Fax: (734) 656-0261
contact@cubearing.com
www.cubearing.com

SEE OUR AD
P32

CCVI Bearing
 Carlisle Power Transmission
 Central Gear & Machine
 Certified Reducer Builders Inc
 Challenge Power Transmission (Aust) Pty Ltd
 Challenge Power Transmission PLC
 Climax Metal Products Company
 Core Supply LLC
 Craft Bearing Company, Inc.
 Cross + Morse
 D&D Intl. Corp.
 Daemar Inc.
 Dalton Bearing Service, Inc.
 Danaher Motion and Thomson

Del-Tron Precision Inc. Designatronics, Inc.

2101 JERICHO TURNPIKE, NEW HYDE PARK, NY 11040
 Phone: (516) 328-3300
 Fax: (516) 326-8827
info@designatronics.com
www.designatronics.com

SEE OUR AD
BACK COVER
P34,35,
40,42,45

Discovery Technology International, Inc.
 Drive Components LLC
 Drive Lines Technologies Ltd
 EDT Corp
 Electro Static Technology
 Emerson Power Transmission
 F.K. Bearings
 FK Bearing Corp.
 FMC Engineering
 Formsprag Clutch
 Fusion Babbitting Co, Inc
 GMB Associates
 GMN Bearing Usa, Ltd.
 Gil Equipamentos Industriais Ltda.
 Hangzhou Xingda Machinery Co. Ltd.
 Hebei Kaidi Bearing (Group) Co., Ltd.
 Houston Pump and Gear
 IBT, Inc

IDC-USA

933 WESTERN DRIVE, INDIANAPOLIS, IN 46241
 Phone: (317) 244-9200
 Fax: (317) 244-4600
sswaim@idc-usa.com
www.IDC-USA.com

SEE OUR AD
P29

IMO USA Corp.
 Industrial Friction Materials Ltd.
 Intellidrives, Inc
 International Distribution Alliance, Inc. (IDA, In
 Kaydon Corporation Bearings Division
 Kilian Manufacturing Corp.
 Kinefac Corporation
 LM76 Linear Motion Bearings
 LYC North America Inc

Luoyang SBI Special Bearing Co. Ltd.

WEISI ROAD
 LUOYANG INDUSTRIAL PARK
 XIGONG HENAN PROVINCE
 CHINA
 Phone: +(86) 379-64122001
 Fax: +(86) 379-64122002
judy@sbi.com.cn
www.sbibearings.com

SEE OUR AD
P10

MMB Bearing Co. Inc.
 MT Tool & Manufacturing
 Maguire Technologies

Martin Sprocket & Gear

3100 SPROCKET DRIVE, ARLINGTON, TX 76015
 Phone: (817) 258-3000
 Fax: (817) 258-3333
mail@martinsprocket.com
www.martinsprocket.com

SEE OUR AD
P31

Micronor Inc.
 Mineral Circles Bearings
 Modern Linear Inc.
 Motion Industries
 Moventas Ltd.

1.88ThinkNSK (888.446.5675) www.nskamericas.com

NSK Corporation

4200 GOSS ROAD
 ANN ARBOR, MI 48105
 Phone: (888) 446-5675
strackh@nsk-corp.com
www.nskamericas.com

SEE OUR AD
P32

Nachi America Inc.
 Napoleon Engineering Services
 Netshape Technologies, Inc.
 Novotec Argentina SRL
 Ondrives Ltd
 Onvio LLC
 PIC Design
 PTD Outlet: Power Transmission Distributors
 Pacamor Kubar Bearings (pkb)
 Pacific Bearing
 Pacific Industries
 Paul's Transmission Shenzhen Co.,Ltd
 Peer Bearing Company
 Pioneer Bearing Company
 Powermach Import & Export Co.,Ltd
 Pulley Manufacturers International Inc.

QA1 Precision Products

21730 HANOVER AVE, LAKEVILLE, MN 55044
 Phone: (800) 721-7761
 Fax: (952) 985-5679
sales@qa1.net
www.qa1.net/industrial

SEE OUR AD
P2



THOTH

Quality Achievement Dream

Ningbo Zhongyi Hydraulic Motor Co, Ltd was found in 1971, which is the high tech mfg. expert of orbital motors, steering control units, transmission and mobile motors. At present we have two manufacturing bases, one is in Ningbo city covering an area of 44,000 square meters, the other one is in Wuhu city with an area of 80,000 square meters. Our manufacturing workshop meets the international standards and the manufacture and test equipments are leading technologically home and abroad. The staffs of Zhongyi will creat first class products, services and brand hands in hands with you.

For more information, pls visit www.zihyd.com.

Email: sales@zihyd.com Linda@zihyd.com

Tel: 0086-574-86378895 Fax: 0086-574-86378310



QBC the Bearing Marketplace

Configurable Bearings
Press Bearings
Thin Section
Rod Ends



www.qbcbearings.com

Designatronics inc.

Quality Bearings & Components

2101 JERICHO TURNPIKE, NEW HYDE PARK, NY 11040

Phone: (516) 616-0436

Fax: (516) 616-0443

qbcsupport@qbcbearings.com

www.qbcbearings.com

SEE OUR AD
P34

RBI Bearing Inc.
RGW Sales Canada
RUBENA a.s.
Rathipolybond Pty Ltd.
René Baer AG
Ringball Corporation
Ritbearing Corp.
Rockwell Automation

SKF USA Inc.

890 FORTY FOOT ROAD, LANSDALE, PA 19446

Phone: (267) 436-6000

www.skf.com

SEE OUR AD
P3

SKG Enterprises
SYX Bearing

Schaeffler Group USA, Inc

308 SPRINGHILL FARM ROAD
FORT MILL, SC 29715

Phone: (803) 548-1800

Fax: (803) 548-8599

www.schaeffler.us

SEE OUR AD
P7

Specialty Motions, Inc.
Sprockets Australia Pty. Ltd.

Sterling Instrument

2101 JERICHO TURNPIKE, NEW HYDE PARK, NY 11040

Phone: (516) 328-3300

Fax: (516) 326-8827

sdp-sisupport@sdp-si.com

www.sdp-si.com

SEE OUR AD
BACK COVER
P42,45

Stock Drive Products

2101 JERICHO TURNPIKE, NEW HYDE PARK, NY 11040

Phone: (516) 328-3300

Fax: (516) 326-8827

sdp-sisupport@sdp-si.com

www.sdp-si.com

SEE OUR AD
BACK COVER
P35,40

Supreme Gear Co.
T.E.A. Machine Components
TB Wood's
TSS Rotterdam B.V.
Tef - Cap Industries
Top Machinery & Equipment (Zhengzhou) Ltd
Torque Transmission
Transply Inc.
Tristate Bearing & Supply Co. Inc.
Trojan Gear Inc.
Tsubaki of Canada Limited
VL Motion Systems Inc.
Vision Quality Components, Inc
WD Bearing America
WMH Transmissions Ltd
Wyko - London & Overseas Supplies
Xuzhou BeiLai Engineering Machinery Co., Ltd
Yogi Bearings
pylon Gears (Pty) Ltd

SEE OUR AD
P21

Ace World Companies
Acorn Industrial Services
Agro Engineers
Akron Gear and Engineering
Amacoil, Inc.
Aman Transmission Co
American Gear & Engineering
American Gear, Inc.
American Plastics Depot
Ametric / American Metric Corporation
Area Distributors Inc.
Ascent Precision Gear Corporation
Ashutosh Power TransBelts Limited
Avion Technologies Inc.
B&B Manufacturing, Inc.
BDI - Bearing Distributors Inc.
BRECOflex CO., L.L.C.

Baldor Electric Company

5711 R.S. BOREHAM, JR. ST.

P.O. BOX 2400

FORT SMITH, AR 72901

Phone: (479) 646-4711

Fax: (479) 648-5792

www.baldor.com

Bearing Service Company
Beijing THC Limited
Belcon Engineers P. Ltd.
Bervina
Bishop-Wisecarver Corp.
Boca Bearing Company
Bowman Hollis Mfg
Brevini Power Transmission - Canada
Brewer Machine & Gear Co.
Butler Gear
Calicut Engineering Works Limited
Capstan Atlantic
Carlisle Power Transmission
Carnes-Miller Gear Co., Inc.

BELTS & BELT DRIVES

ABL Products Incorporated
Accent Bearings Co. Inc.

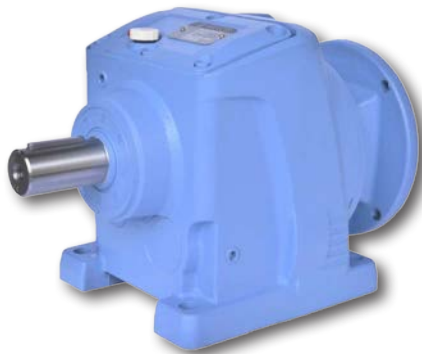

In Stock!

Helical Inline Speed Reducers:

- 1/4 HP - 75 HP; ALL RATINGS IN STOCK
- Box sizes: 37 - 147; Ratios: 5:1 - 120:1
- Cast iron housing is precision processed for better rotation and quieter operation
- Drop-in replacement for most major inline reducer brands
- 2 year warranty

CALL US NOW TO GET YOUR SPECIAL PRICING!



WorldWide Electric Corporation

1-800-808-2131

www.worldwideelectric.net

Certified Reducer Rebuilders Inc
Challenge Power Transmission (Aust) Pty Ltd
Challenge Power Transmission PLC
Clark Gear Works, Inc.
Clarke Engineering Inc. (Clarke Gear Co.)
ComInTec Srl
Commercial Gear & Sprocket Co. Inc.

Cone Drive

240 EAST 12TH STREET
TRAVERSE CITY, MI 49685-0272
Phone: (888) 994-2663
Fax: (888) 907-2663
orders@conedrive.com
www.conedrive.com

SEE OUR AD
P39

Conroll Corporation



Continental

ContiTech

ContiTech North America

136 SUMMIT AVENUE
MONTVALE, NJ 07645
Phone: (201) 930-0600
info@contitech-usa.com
www.contitech.us

SEE OUR AD
P35

Core Supply LLC

Cross + Morse
Custom Machine & Tool Co. Inc.
D&D Intl. Corp.
Dalton Bearing Service, Inc.
Darbar Belting
Davall Gears Ltd.
Dee Bee Enterprise
Del-Tron Precision Inc.
Delta Gear Corp.

Designatronics, Inc.

2101 JERICHO TURNPIKE, NEW HYDE PARK, NY 11040
Phone: (516) 328-3300
Fax: (516) 326-8827
info@designatronics.com
www.designatronics.com

SEE OUR AD
BACK COVER
P34, 35,
40, 42, 45

Dimatic Die & Tool Co.

Drive Components LLC
Dura-Belt
Dymco, Co
Electro Steel Engineering Company
Emerson Power Transmission

Excel Gear, Inc.

11865 MAIN STREET, ROSCOE, IL 61073
Phone: 815-623-3414
Fax: 815-623-3314
chinn@excelgear.com
www.excelgear.com

SEE OUR AD
P22

First Gear Engineering & Technology

7606 FREEDOM WAY
FORT WAYNE, IN 46818
Phone: (260) 490-3238
Fax: (260) 490-4093
greg@first-gear.com
www.first-gear.com

SEE OUR AD
P11

Forest City Gear Co.

11715 MAIN STREET
ROSCOE, IL 61073
Phone: (815) 623-2168
Fax: (815) 623-6620
rmikel@fcgear.com
www.fcgear.com

SEE OUR AD
P13

GMB Associates
Gates Corporation

Gayatri Gear Industries
Gear Design & Service Pty. Ltd.
George Lane & Sons Ltd
Gil Equipamentos Industriais Ltda.
Hangzhou Xingda Machinery Co. Ltd.
Hayes Manufacturing Inc.
IBT, Inc

IDC-USA

933 WESTERN DRIVE, INDIANAPOLIS, IN 46241
Phone: (317) 244-9200
Fax: (317) 244-4600
sswaim@idc-usa.com
www.IDC-USA.com

SEE OUR AD
P29

Industrial Jig & Fixture
Industrial Pulley & Machine Co, Inc.
Intech Corporation
Jason Industrial Inc.
Kamar Industries
Kapsyn Manufacturing Company
LEESON Electric
Lovejoy, Inc.
MGT - Magnetic Gearing & Turbine Corp.
MT Tool & Manufacturing
Maguire Technologies

Martin Sprocket & Gear

3100 SPROCKET DRIVE, ARLINGTON, TX 76015
Phone: (817) 258-3000
Fax: (817) 258-3333
mail@martinsprocket.com
www.martinsprocket.com

SEE OUR AD
P31

Maurey Manufacturing Corporation
Midwest Brake
Milltex Engineering Company
Ming Chang Traffic Parts Mfg.
Motion Industries
Nav Auxichem Pvt. Ltd
Neelkanth Belting
Netshape Technologies, Inc.
New England Belting Company
North American Clutch Corp. (noram)
Novotec Argentina SRL
Ongears - Ondrives Export Gears
Ontario Gear and Spline
Onvio LLC
PIC Design

PTD Outlet: Power Transmission Distributors
Paul's Transmission Shenzhen Co.,Ltd
Pix Europe Limited
Pix Transmissions Limited
Plastock - Putnam Precision Molding, Inc.
Popular Mechanical Works
Powermach Import & Export Co.,Ltd
Premier Udyog
Pulley Manufacturers International Inc.
Quality Transmission Components
RUBENA a.s.
René Baer AG
Ringball Corporation
Rockwell Automation
Rowland Co., The
Rush Gears Inc.

SKF USA Inc.

890 FORTY FOOT ROAD, LANSDALE, PA 19446
Phone: (267) 436-6000
www.skf.com

SEE OUR AD
P3

SKG Enterprises
Sallex Machine Tools
Schafer Industries
Sprockets Australia Pty. Ltd.

SDP Stock Drive Products

Setting Ideas into Motion

Engineered Synchronous
Drive Solutions

Off-the-shelf

www.sdp-si.com

Designatronics inc.



Stock Drive Products

2101 JERICHO TURNPIKE, NEW HYDE PARK, NY 11040
Phone: (516) 328-3300
Fax: (516) 326-8827
sdp-sisupport@sdp-si.com
www.sdp-si.com

SEE OUR AD
BACK COVER
P35, 40

Supreme Gear Co.
T.E.A. Machine Components
TB Wood's
TSS Rotterdam B.V.
TVT America, Inc.
Team Industries
Tolomatic, Inc.
Tool Masters India
Top Machinery & Equipment (Zhengzhou) Ltd
Torque Transmission
Transply Inc.
Tristate Bearing & Supply Co. Inc.
Trojon Gear Inc.
Tsubaki of Canada Limited
VL Motion Systems Inc.
Vision International
Vision Quality Components, Inc
Volta Belting
WMH Transmissions Ltd
Wyko - London & Overseas Supplies
Yogi Bearings
Zeon Belts Pvt. Ltd.
pylon Gears (Pty) Ltd

BRAKES

Acionac Indústria E Comércio
Andantex USA Inc.
Applied Power Solutions
Area Distributors Inc.
BDI - Bearing Distributors Inc.
Beaver Aerospace and Defense Inc.
Bison Gear and Engineering Corp.
Brevini Power Transmission - Canada
Carlyle Johnson Machine Co. LLC, The
Certified Reducer Rebuilders Inc
Coremo Ocmea S.r.l.
Cryotron Magnadrives
Currie Enterprises
Dalton Bearing Service, Inc.
Danaher Motion and Thomson
Dellner Brakes AB

Designatronics, Inc.

2101 JERICHO TURNPIKE, NEW HYDE PARK, NY 11040
Phone: (516) 328-3300
Fax: (516) 326-8827
info@designatronics.com
www.designatronics.com

SEE OUR AD
BACK COVER
P34, 35,
40, 42, 45

Dings Company
Drive Lines Technologies Ltd
Dunkermotoren USA Inc.
Electromatic Engineers Pvt. Ltd
Emco Dynatorq Pvt. Ltd. (Formerly Emco Lenze Pvt.
Force Control Industries
GMB Associates
Gummi Usa
Hilliard Corp., The
Hoffmann Technics Ag
IBT, Inc
Industrial Clutch Parts Ltd.

Industrial Friction Materials Ltd.
Inertia Dynamics, Inc.
JVL Industri Elektronik A/S
Johnson Industries Ltd.

KTR Corporation

122 ANCHOR ROAD, MICHIGAN CITY, IN 46360
Phone: (219) 872-9100
Fax: (219) 872-9150
ktr-us@ktr.com
www.ktr.com

SEE OUR AD
P39,40**Klam America Corporation****Lafert North America**

5620 KENNEDY RD.
MISSISSAUGA ON L4Z 2A9
CANADA
Phone: (905) 629-1939 or toll free (800) 661-6413
Fax: (905) 629-2852
ptsales@lafertna.com
www.lafertna.com

SEE OUR AD
P15

MICO, Incorporated
Mach III Clutch Inc.
Magnetic Technologies Ltd
Magtrol, Inc.
Marshall Wolf Automation Inc.
Matrix International
Mayr Corporation
Midwest Brake
Midwest Motion Products
Motion Industries
New Torque, Inc.

Ningbo Zhongyi Hydraulic Motor Co. Ltd.

NINGBO ZHENHAI ECONOMIC DEVELOPMENT ZONE
ROAD 88, ITALY
NINGBO
CHINA
Phone: +(86) 574-86261172-800
Fax: +(86) 574-86288064
sales@zihyd.com
www.zihyd.com

SEE OUR AD
P33**North American Clutch Corp. (noram)**

Novotec Argentina SRL
Onvio LLC
Orttech
PIC Design
PTD Outlet: Power Transmission Distributors
Palmer Johnson Power Systems
Pethe Engineering Private Limited
Power Transmission Engineers
Precipart
Ringspann Corporation
Rockwell Automation
Rowland Co., The
Sprockets Australia Pty. Ltd.
Stearns Division / Rexnord Industries Inc.
Stephenson Gobin Transmissions

Sterling Instrument

2101 JERICHO TURNPIKE, NEW HYDE PARK, NY 11040
Phone: (516) 328-3300
Fax: (516) 326-8827
sdp-sisupport@sdp-si.com
www.sdp-si.com

SEE OUR AD
BACK COVER
P42,45**Stock Drive Products**

2101 JERICHO TURNPIKE, NEW HYDE PARK, NY 11040
Phone: (516) 328-3300
Fax: (516) 326-8827
sdp-sisupport@sdp-si.com
www.sdp-si.com

SEE OUR AD
BACK COVER
P35,40

TB Wood's
Taiwan Precision Gear Corp.
Team Industries
Tolomatic, Inc.
Transply Inc.
Twiflex Limited
VL Motion Systems Inc.
Vortex Engineering Works
WPT Power Corporation
Wyko - London & Overseas Supplies

CHAIN & CHAIN DRIVES

ABL Products Incorporated
Accent Bearings Co. Inc.
Accurate Gear and Machine, Inc.
Acorn Industrial Services
Agro Engineers
Akron Gear and Engineering
American Plastics Depot
Ametric / American Metric Corporation
Area Distributors Inc.
Ascent Precision Gear Corporation
B&B Manufacturing, Inc.

B&R Machine and Gear Corp.

4809 U.S. HWY. 45
SHARON TN 38255
Phone: (731) 456-2636 or (800) 238-0651
Fax: (731) 456-3073
inquiry@brgear.com
www.brgear.com

SEE OUR AD
P9

BDI - Bearing Distributors Inc.
Bearing Service Company
Bearings Limited
Beijing THC Limited
Bishop-Wisecarver Corp.
Bowman Hollis Mfg
Brevini Power Transmission - Canada
Brewer Machine & Gear Co.
C-B Gear & Machine
Calicut Engineering Works Limited
Central Gear & Machine
Certified Reducer Builders Inc
Challenge Power Transmission (Aust) Pty Ltd
Challenge Power Transmission PLC
Cloyes Gear & Products Inc.
Commercial Gear & Sprocket Co. Inc.
Core Supply LLC
Cross + Morse
D&D Intl. Corp.
Daido Corporation of America
Dalton Bearing Service, Inc.
Darbar Belting
Davall Gears Ltd.

Designatronics, Inc.

2101 JERICHO TURNPIKE, NEW HYDE PARK, NY 11040
Phone: (516) 328-3300
Fax: (516) 326-8827
info@designatronics.com
www.designatronics.com

SEE OUR AD
BACK COVER
**P34,35,
40,42,45**

Diamond Chain Company
Electro Steel Engineering Company
Emerson Power Transmission

First Gear Engineering & Technology

7606 FREEDOM WAY
FORT WAYNE, IN 46818
Phone: (260) 490-3238
Fax: (260) 490-4093
greg@first-gear.com
www.first-gear.com

SEE OUR AD
P11

Framo Morat Inc.
GMB Associates
Gates Corporation
Gayatri Gear Industries
Gear Master Inc.
Hangzhou Xingda Machinery Co. Ltd.
Henan Contrust Gear Transmission Co., Ltd.
IBT, Inc

IDC-USA

933 WESTERN DRIVE, INDIANAPOLIS, IN 46241
Phone: (317) 244-9200
Fax: (317) 244-4600
sswaim@idc-usa.com
www.IDC-USA.com

SEE OUR AD
P29

Kamar Industries
MGT - Magnetic Gearing & Turbine Corp.
MT Tool & Manufacturing

Martin Sprocket & Gear

3100 SPROCKET DRIVE, ARLINGTON, TX 76015
Phone: (817) 258-3000
Fax: (817) 258-3333
mail@martinsprocket.com
www.martinsprocket.com

SEE OUR AD
P31

Ming Chang Traffic Parts Mfg.
Motion Industries
Moventas Ltd.
North American Clutch Corp. (noram)
Nu-Teck Couplings Pvt. Ltd
PIC Design
PTD Outlet: Power Transmission Distributors
Pacific Industries
Paul's Transmission Shenzhen Co.,ltd
Peer Bearing Company
Performance Gear Systems, Inc.
Pix Europe Limited
Pix Transmissions Limited
Plastock - Putnam Precision Molding, Inc.
Powermach Import & Export Co.,ltd
Pulley Manufacturers International Inc.
Quality Transmission Components
RBI Bearing Inc.
René Baer AG
Ringball Corporation
Rockwell Automation
Rowland Co., The

SKF USA Inc.

890 FORTY FOOT ROAD, LANSDALE, PA 19446
Phone: (267) 436-6000
www.skf.com

SEE OUR AD
P3

SKG Enterprises
ST Gear & Machine LLC
Serapid Inc.
Sprockets Australia Pty. Ltd.

Stock Drive Products

2101 JERICHO TURNPIKE, NEW HYDE PARK, NY 11040
Phone: (516) 328-3300
Fax: (516) 326-8827
sdp-sisupport@sdp-si.com
www.sdp-si.com

SEE OUR AD
BACK COVER
P35,40

Team Industries
Torque Transmission
Transply Inc.
Tristate Bearing & Supply Co. Inc.
Trojan Gear Inc.
Tsubaki of Canada Limited
VL Motion Systems Inc.
WMH Transmissions Ltd
Wyko - London & Overseas Supplies
Yogi Bearings

CLUTCHES

AISCO Industrial Couplings
Accent Bearings Co. Inc.
Acionac Indústria E Comércio
Andantex USA Inc.
Applied Power Solutions
Area Distributors Inc.
Ascent Precision Gear Corporation
Bearing Service Company
Bibby Transmissions
Boston Gear
CENTA Corp.

Cabat Inc.

5501 21ST STREET
RACINE WI 53401-1616
Phone: (262) 898-5937
Fax: (262) 554-7503
Bgreuel@cabatinc.com
www.cabatinc.com

SEE OUR AD
P2

Carlyle Johnson Machine Co. LLC, The
Certified Reducer Builders Inc
ComInTec Srl
Commercial Gear & Sprocket Co. Inc.
Coremo Omcea S.r.l.



THE SURVIVOR

FOR EXTREME DUTY POWER TRANSMISSION:
OUR ZERO MAINTENANCE DISC PACK COUPLINGS.

Cross + Morse
Cryotron Magnadrives
D G Steel & Son Engineering Ltd.
Dalton Bearing Service, Inc.
Danaher Motion and Thomson
Davall Gears Ltd.
Desch Canada Ltd.

Designatronics, Inc.

2101 JERICHO TURNPIKE, NEW HYDE PARK, NY 11040

Phone: (516) 328-3300

Fax: (516) 326-8827

info@designatronics.com

www.designatronics.com

SEE OUR AD
BACK COVER
P34,35,
40,42,45

DieQua Corp.

180 COVINGTON DRIVE, BLOOMINGDALE, IL 60108

Phone: (630) 980-1133

Fax: (630) 980-1232

info@diequa.com

www.diequa.com

SEE OUR AD
P17

Drive Lines Technologies Ltd
Electromatic Engineers Pvt. Ltd
Emco Dynatorq Pvt. Ltd. (Formerly Emco Lenze Pvt.
Equipment Concepts
Force Control Industries
Formsprag Clutch
GMB Associates
GMN Bearing Usa, Ltd.
Ghatge Patil Industries
Gummi Usa
Hilliard Corp., The
Howdon Power Transmission Limited
Huco Dynatork
IBT, Inc
Industrial Clutch Parts Ltd.
Industrial Friction Materials Ltd.
Inertia Dynamics, Inc.

KTR Corporation

122 ANCHOR ROAD, MICHIGAN CITY, IN 46360

Phone: (219) 872-9100

Fax: (219) 872-9150

ktr-us@ktr.com

www.ktr.com

SEE OUR AD
P39,40

Bkb Antriebstechnik GmbH
Mach III Clutch Inc.
Magnetic Technologies Ltd
Magtrol, Inc.
Marine Specialties, Inc.
Marshall Wolf Automation Inc.
Matrix International
Mayr Corporation
Means Industries, Inc.
Midwest Brake
Motion Industries
Moventas Ltd.
New Torque, Inc.
North American Clutch & Driveline
North American Clutch Corp. (noram)
Novotec Argentina SRL
Orttech
PIC Design
PTD Outlet: Power Transmission Distributors
Palmer Johnson Power Systems
Pethe Engineering Private Limited
Power Transmission Engineers
Precipart

R+W America

1120 TOWER LANE, BENSENVILLE, IL 60106

Phone: (630) 521-9911

Fax: (630) 521-0366

info@rw-america.com

www.rw-america.com

SEE OUR AD
P37

René Baer AG
Ringspann Corporation
Rockwell Automation
Rowland Co., The
SIPCO-MLS
Sprockets Australia Pty. Ltd.

Stearns Division / Rexnord Industries Inc.
Stephenson Gobin Transmissions

Sterling Instrument

2101 JERICHO TURNPIKE, NEW HYDE PARK, NY 11040

Phone: (516) 328-3300

Fax: (516) 326-8827

sdp-sisupport@sdp-si.com

www.sdp-si.com

SEE OUR AD
BACK COVER
P42,45

Stieber Clutch

Stock Drive Products

2101 JERICHO TURNPIKE, NEW HYDE PARK, NY 11040

Phone: (516) 328-3300

Fax: (516) 326-8827

sdp-sisupport@sdp-si.com

www.sdp-si.com

SEE OUR AD
BACK COVER
P35,40

Supreme Gear Co.

T.E.A. Machine Components

TB Wood's

Taiwan Precision Gear Corp.

Team Industries

Tolomatic, Inc.

Transply Inc.

Tristate Bearing & Supply Co. Inc.

Twiflex Limited

VL Motion Systems Inc.

Vortex Engineering Works

WPT Power Corporation

Wyko - London & Overseas Supplies

CONTROLS

ACS Motion Control
Ace World Companies
Advanced Control Systems Corporation
Aerotech Inc.
Allied Motion
American Rotary Industrial Power Source
Anaheim Automation, Inc.
Applied Power Solutions
Area Distributors Inc.

Automation Direct

3505 HUTCHINSON ROAD, CUMMING, GA 30040

Phone: (800) 633-0405

Fax: (770) 844-4212

sales@automationdirect.com

www.automationdirect.com

SEE OUR AD
INSIDE FRONT COVER

BDI - Bearing Distributors Inc.

Baldor Electric Company

5711 R.S. BOREHAM, JR. ST.

P.O. BOX 2400

FORT SMITH, AR 72901

Phone: (479) 646-4711

Fax: (479) 648-5792

www.baldor.com

SEE OUR AD
P21

Bearing Service Company
Binsfeld Engineering Inc.
Bodine Electric Company
Bonfiglioli Riduttori S.p.A.
Bonfiglioli USA
Boston Gear
Carlyle Johnson Machine Co. LLC, The
Conroll Corporation
Control Switches International Inc (csii)
Core Supply LLC
Custom Sensors & Technologies
Cutes Corporation
Dalton Bearing Service, Inc.
Danaher Motion and Thomson
Dellner Brakes AB

DieQua Corp.

180 COVINGTON DRIVE, BLOOMINGDALE, IL 60108

Phone: (630) 980-1133

Fax: (630) 980-1232

info@diequa.com

www.diequa.com

SEE OUR AD
P17

Dn Sales Australia
Drive Lines Technologies Ltd

Dunkermotoren USA Inc.
Dynamic Structures and Materials, LLC
Electronic Machine Parts
Emerson Industrial Automation - Drives & Motor
FSI Technologies Inc.
Festo Corporation
Fife Corporation
Force Control Industries
GMB Associates
HEIDENHAIN Corporation
HPB Motion Control Co. Ltd.
Hallmark Industries Inc.
Hansen Motor Corporation
Hoffmann Technics Ag
IBT, Inc

IDC-USA

933 WESTERN DRIVE, INDIANAPOLIS, IN 46241

Phone: (317) 244-9200

Fax: (317) 244-4600

sswaim@idc-usa.com

www.IDC-USA.com

SEE OUR AD
P29

Industrial Clutch Parts Ltd.
Inertia Dynamics, Inc.
Intellidrives, Inc
JVL Industri Elektronik A/S
Johnson Industries Ltd.
K+S Services
KB Controls
LEESON Electric
MICO, Incorporated
MROSupply
Magtrol, Inc.
Marshall Wolf Automation Inc.
Mavilor Motors, S.a.
Maxon Precision Motors Inc
Micronor Inc.
Midwest Motion Products
Mitsubishi Electric Automation, Inc.
Motion Industries
New Power Electric (USA) LLC
New Torque, Inc.
Norwin Electronics Limited
Novotec Argentina SRL
Onvio LLC
Ormec
PI (Physik Instrumente) L.P. Piezo Actuator Nano
PTD Outlet: Power Transmission Distributors
Parker Hannifin - SSD Drives Div.
Parker Hannifin Electromechanical Automation Divis
Phytron, Inc.
Potomac Electric
Precipart
Regent Controls, Inc
Rockwell Automation
Rowland Co., The

SEW-Eurodrive

1295 OLD SPARTANBURG HWY., LYMAN, SC 29635

Phone: (864) 439-7537

Fax: (864) 439-7830

www.seweurodrive.com

SEE OUR AD
INSIDE BACK COVER

SKF USA Inc.

890 FORTY FOOT ROAD, LANSDALE, PA 19446

Phone: (267) 436-6000

www.skf.com

SEE OUR AD
P3

Sesame Motor Corp.
Siemens Industry, Inc.
Siti Spa Riduttori
Source Engineering Inc.
Specialty Motions, Inc.
Stearns Division / Rexnord Industries Inc.
Taiwan Precision Gear Corp.
Tapeswitch Corporation
Team Industries
Teco Westinghouse
TelcoMotion
Tolomatic, Inc.
Transply Inc.

Twiflex Limited
VL Motion Systems Inc.
WEG

Worldwide Electric Corp.
1 GROVE ST. #201B
PITTSFORD, NY 14534
Phone: (800) 808-2131
Fax: (800) 711-1616
www.worldwideelectric.net

SEE OUR AD
P34

Wyko - London & Overseas Supplies

Yaskawa America, Inc.
DRIVES & MOTORS DIVISION
2121 NORMAN DRIVE SOUTH
WAUKEGAN, IL 60085
Phone: (800) 927-5292
Fax: (847) 887-7310
tom_kutcher@yaskawa.com
www.yaskawa.com

SEE OUR AD
P19

COUPLINGS & U-JOINTS

AGI Automation Components
AISCO Industrial Couplings
Accent Bearings Co. Inc.
Accurate Gear and Machine, Inc.
Acicon Equipos Indls Ltda
Acionac Indústria E Comércio
Acorn Industrial Services
Agro Engineers
Ameridrives
Ameridrives Power Transmission
Ametric / American Metric Corporation
Annflex Bellows & Compensators
Applied Power Solutions
Area Distributors Inc.
Ascent Precision Gear Corporation
Atlanta Gear Works, Inc
Axu S.r.l.

B&R Machine and Gear Corp.
4809 U.S. HWY. 45
SHARON TN 38255
Phone: (731) 456-2636 or (800) 238-0651
Fax: (731) 456-3073
inquiry@brgear.com
www.brgear.com

SEE OUR AD
P9

BDI - Bearing Distributors Inc.
BRECOflex CO., L.L.C.
Baker Bearing Company
Bearing Service Company
Beijing THC Limited
Belcon Engineers P. Ltd.
Belden Inc.
BellowsTech, LLC
Bervina
Bevel Gears India Pvt. Ltd.
Bibby Transmissions
Boneng Transmission USA LLC
Boston Gear
Brevini Power Transmission - Canada
C-B Gear & Machine
CENTA Corp.

Cabat Inc.
5501 21ST STREET
RACINE WI 53401-1616
Phone: (262) 898-5937
Fax: (262) 554-7503
Bgreuel@cabatinc.com
www.cabatinc.com

SEE OUR AD
P2

Calicut Engineering Works Limited
Carlyle Johnson Machine Co. LLC, The
Certified Reducer Rebuilders Inc
Cestari Industrial e Comercial S.A.
Challenge Power Transmission (Aust) Pty Ltd
Challenge Power Transmission PLC
Chengdu Talent Industrial Co., Ltd.
Climax Metal Products Company
ComInTec Srl
Commercial Gear & Sprocket Co. Inc.



SYNTAX®
Torque Limiter

BoWex® GT
Coupling

ROTEX®
Curved Jaw Coupling

Power Transmission Solutions

- One-stop shopping for power transmission components
- Quality, reliability & compact design
- Online selection tools

KTR Corporation
219-872-9100
www.ktr.com

STAINLESS Steel



Our **NEW** Stainless Steel gearboxes are IP 69K rated. The smooth and rounded surface allows for easy cleaning.

- Non-fretting motor connection
- IP 69K rated
- Dimensional drop-in for most worm gear manufacturers
- Cone Drive TRUE Double-Enveloping worm gearing



ENGINEERED TO KEEP YOU MOVING.
(888) 994-2663 www.conedrive.com

Made for Motion



BoWex® HE



BoWex® with GT Sleeve



ROTEX® with Split Hubs



ROTEX® GS Zero Backlash



RIGIFLEX® N

Solutions for every application.
KTR Couplings keep you
up and running.

KTR Corporation
219-872-9100
www.ktr.com

Core Supply LLC
Cross + Morse
Custom Machine & Tool Co. Inc.
Dalton Bearing Service, Inc.
Davall Gears Ltd.
David Brown
DePe Gear Company Ltd
Desch Canada Ltd.

Designatronics, Inc.

2101 JERICHO TURNPIKE, NEW HYDE PARK, NY 11040

Phone: (516) 328-3300

Fax: (516) 326-8827

info@designatronics.com

www.designatronics.com

SEE OUR AD
BACK COVER
P34,35,
40,42,45

DieQua Corp.

180 COVINGTON DRIVE, BLOOMINGDALE, IL 60108

Phone: (630) 980-1133

Fax: (630) 980-1232

info@diequa.com

www.diequa.com

SEE OUR AD
P17

Dn Sales Australia
Drive Lines Technologies Ltd
Duff Norton Australia
Electro Steel Engineering Company
Electromatic Engineers Pvt. Ltd
Emerson Power Transmission
Equipment Concepts
Flexocon Engineers Private Limited
Formsprag Clutch
GAM Gear
GMB Associates
Gayatri Gear Industries
Gear Master Inc.
Ghatge Patil Industries
Gleason K2 Plastics
Gummi USA
Hangzhou Xingda Machinery Co. Ltd.
Hayes Manufacturing Inc.
Henan Contrust Gear Transmission Co., Ltd.
Hi-Grade Inc.
Houston Pump and Gear
Huco Dynatork
IBT, Inc

IDC-USA

933 WESTERN DRIVE, INDIANAPOLIS, IN 46241

Phone: (317) 244-9200

Fax: (317) 244-4600

sswaim@idc-usa.com

www.IDC-USA.com

SEE OUR AD
P29

Industrial Clutch Parts Ltd.
Inertia Dynamics, Inc.

Couplings,
Hydraulic Coolers
& Components,
Brake Systems

Made for Motion



122 Anchor Rd
Michigan City, IN 46360
Phone: 219-872-9100
ktr_us@ktr.com
www.ktr.com

**KTR Corporation**

122 ANCHOR ROAD, MICHIGAN CITY, IN 46360

Phone: (219) 872-9100

Fax: (219) 872-9150

ktr-us@ktr.com

www.ktr.com

SEE OUR AD
P39,40

Kbk Antriebstechnik GmbH
Kinefac Corporation
Lovejoy, Inc.
MAV S.p.A.
MGT - Magnetic Gearing & Turbine Corp.
Mach III Clutch Inc.
Magnetic Technologies Ltd
Marine Specialties, Inc.

Martin Sprocket & Gear

3100 SPROCKET DRIVE, ARLINGTON, TX 76015

Phone: (817) 258-3000

Fax: (817) 258-3333

mail@martinsprocket.com

www.martinsprocket.com

SEE OUR AD
P31

Master Bond, Inc.
Matrix International
Maurey Manufacturing Corporation
Mayr Corporation
Minsk Gear Works
Motion Industries
Moventas Ltd.
NDE Power Transmissions
Netshape Technologies, Inc.
North American Clutch Corp. (noram)
Novotec Argentina SRL
Nu-Teck Couplings Pvt. Ltd
OEP Couplings, a Division of Oren Elliott Products
Ondrives Ltd
Orttech
PIC Design
PTD Outlet: Power Transmission Distributors
Pacific Industries
Palmer Johnson Power Systems
Paul's Transmission Shenzhen Co., Ltd
Pix Europe Limited
Pix Transmissions Limited
Popular Mechanical Works
Powermach Import & Export Co. Ltd.

R+W America

1120 TOWER LANE, BENSENVILLE, IL 60106

Phone: (630) 521-9911

Fax: (630) 521-0366

info@rw-america.com

www.rw-america.com

SEE OUR AD
P37

RUBENA a.s.
Rathipolybond Pty Ltd.
René Baer AG
Ringball Corporation
Ringspann Corporation
Rowland Co., The
SIPCO-MLS

SKF USA Inc.

890 FORTY FOOT ROAD, LANSDALE, PA 19446

Phone: (267) 436-6000

www.skf.com

SEE OUR AD
P3

Servometer
Siemens Energy & Automation
Siemens Industry, Inc.
Sprockets Australia Pty. Ltd.

Sterling Instrument

2101 JERICHO TURNPIKE, NEW HYDE PARK, NY 11040

Phone: (516) 328-3300

Fax: (516) 326-8827

sdp-sisupport@sdp-si.com

www.sdp-si.com

SEE OUR AD
BACK COVER
P42,45

SDP Stock Drive Products

Setting Ideas into Motion

Engineered Coupling Solutions

Off-the-shelf

www.sdp-si.com

Designatronics^{inc.}**Stock Drive Products**

2101 JERICHO TURNPIKE, NEW HYDE PARK, NY 11040

Phone: (516) 328-3300

Fax: (516) 326-8827

sdp-sisupport@sdp-si.com

www.sdp-si.com

SEE OUR AD
BACK COVER
P35,40

Supreme Gear Co.

T.E.A. Machine Components
 TB Wood's
 TSS Rotterdam B.V.
 TVT America, Inc.
 Taiwan Precision Gear Corp.
 Team Industries
 Timothy Holding Co., Ltd.
 Transply Inc.
 Tristate Bearing & Supply Co. Inc.
 Tsubaki of Canada Limited
 Twiflex Limited
 VL Motion Systems Inc.
 Vision International
 Vision Quality Components, Inc
 WMH Transmissions Ltd
 Wellman Wacoma Limited
 Wittenstein (formerly alpha gear drives)
 Wyko - London & Overseas Supplies
 Xtek, Inc.
 Yogi Bearings
 ZRIME
 Zero-Max
 pylon Gears (Pty) Ltd

FLUID POWER

Acorn Industrial Services
 BDI - Bearing Distributors Inc.
 Brevini Power Transmission - Canada
 CENTA Corp.

Cone Drive

240 EAST 12TH STREET
 TRAVERSE CITY, MI 49685-0272
 Phone: (888) 994-2663
 Fax: (888) 907-2663
 orders@conedrive.com
 www.conedrive.com

SEE OUR AD
P39

Cotta Transmission Co. LLC
 Dalton Bearing Service, Inc.
 Dynex/Rivett Inc.
 Future Technologies, Inc.
 Hayes Manufacturing Inc.
 Helium Leak Testing, Inc.
 Houston Pump and Gear
 Hydraulic Problems ?, Inc.
 IBT, Inc

IDC-USA

933 WESTERN DRIVE, INDIANAPOLIS, IN 46241
 Phone: (317) 244-9200
 Fax: (317) 244-4600
 sswaim@idc-usa.com
 www.IDC-USA.com

SEE OUR AD
P29

K+S Services

KTR Corporation

122 ANCHOR ROAD, MICHIGAN CITY, IN 46360
 Phone: (219) 872-9100
 Fax: (219) 872-9150
 ktr-us@ktr.com
 www.ktr.com

SEE OUR AD
P39,40

Lovejoy, Inc.

MICO, Incorporated
 Motion Industries
 Netshape Technologies, Inc.
 Ngt Specialty Valves

Ningbo Zhongyi Hydraulic Motor Co. Ltd.

NINGBO ZHENHAI ECONOMIC DEVELOPMENT ZONE
 ROAD 88, ITALY
 NINGBO
 CHINA
 Phone: +(86) 574-86261172-800
 Fax: +(86) 574-86288064
 sales@zihyd.com
 www.zihyd.com

SEE OUR AD
P33

OEM International Inc.

Orttech
 Palmer Johnson Power Systems
 Popular Mechanical Works
 RUBENA a.s.

Rowland Co., The
 S.M. Shah & Company
 T.E.A. Machine Components
 TSS Rotterdam B.V.
 TVT America, Inc.
 Var-Spe Variatori Oleodinamici
 Wyko - London & Overseas Supplies
 Zero-Max

GEAR DRIVES

ASI Technologies Inc.
 Accent Bearings Co. Inc.
 Accurate Gear and Machine, Inc.
 Ace World Companies
 Acionac Indústria E Comércio
 Acme Gear Co.
 Acorn Industrial Services
 Aero Gear Inc.
 Agro Engineers
 Akgears, LLC
 Akron Gear and Engineering
 Allen Gears Ltd.
 Allied Motion
 American Gear & Engineering
 American Plastics Depot
 Ametric / American Metric Corporation
 Ancon Gear & Instrument Corp.
 Andantex USA Inc.
 Area Drives Inc.

Arrow Gear Co.

2301 CURTISS STREET
 DOWNERS GROVE, IL 60515
 Phone: (630) 969-7640
 Fax: (630) 969-0253
 quote@arrowgear.com
 www.arrowgear.com

SEE OUR AD
P5

Atlanta Drive Systems Inc.

Atlanta Gear Works, Inc
 Autoparts Solutions PvtLtd
 Avion Technologies Inc.
 B&B Manufacturing, Inc.

B&R Machine and Gear Corp.

4809 U.S. HWY. 45
 SHARON TN 38255
 Phone: (731) 456-2636 or (800) 238-0651
 Fax: (731) 456-3073
 inquiry@brgear.com
 www.brgear.com

SEE OUR AD
P9

BDI - Bearing Distributors Inc.

Baldor Electric Company

5711 R.S. BOREHAM, JR. ST.
 P.O. BOX 2400
 FORT SMITH, AR 72901
 Phone: (479) 646-4711
 Fax: (479) 648-5792
 www.baldor.com

SEE OUR AD
P21

Bauer Gear Motor

Bearing Service Company
 Bevel Gears India Pvt. Ltd.
 Bison Gear and Engineering Corp.
 Bodine Electric Company
 Boneng Transmission (Suzhou) Co., Ltd.
 Boneng Transmission USA LLC
 Bonfiglioli Riduttori S.p.A.
 Bonfiglioli USA
 Boston Gear
 Brad Foote Gear Works, Inc
 Brevini Power Transmission - Canada



brevini
 gear systems

**Established, Tested,
 and Trusted.**

Using technology & innovation to meet
 your needs - now and into the future.

765-759-2128 • info@brevinigeared.com
 brevinigeared.com

Brevini Wind USA

2400 N. PRIORITY WAY
 YORKTOWN, IN 47396
 Phone: (765) 759-2128
 Fax: (765) 759-4728
 dale.harder@brevini.com
 www.breviniwind.com

SEE OUR AD
P16,41,43,44

Broadway Gear

Brother Gearmotors

200 CROSSING BLVD.
 BRIDGEWATER NJ 08807
 Phone: (866) 523-6283
 gearmotors@brother.com
 www.brother-usa.com

SEE OUR AD
P23

Buehler Motor, Inc.

C-B Gear & Machine
 Calicut Engineering Works Limited
 Central Gear & Machine
 Certified Reducer Rebuilders Inc
 Cestari Industrial e Comercial S.A.
 Challenge Power Transmission (Aust) Pty Ltd
 Chenta USA
 Cleveland Gear Co.
 Cogmatic, Inc.
 Columbia Gear Corp.

Cone Drive

240 EAST 12TH STREET
 TRAVERSE CITY, MI 49685-0272
 Phone: (888) 994-2663
 Fax: (888) 907-2663
 orders@conedrive.com
 www.conedrive.com

SEE OUR AD
P39

Cotta Transmission Co. LLC

Currie Enterprises
 Curtis Machine Co. Inc.
 Custom Sensors & Technologies
 Dalton Bearing Service, Inc.
 Danaher Motion and Thomson
 Davall Gears Ltd.
 David Brown
 Delroyd Worm Gear
 Delta Gear Company
 Desch Canada Ltd.

Designatronics, Inc.

2101 JERICHO TURNPIKE, NEW HYDE PARK, NY 11040
 Phone: (516) 328-3300
 Fax: (516) 326-8827
 info@designatronics.com
 www.designatronics.com

SEE OUR AD
 BACK COVER
**P34,35,
 40,42,45**

DieQua Corp.

180 COVINGTON DRIVE, BLOOMINGDALE, IL 60108
 Phone: (630) 980-1133
 Fax: (630) 980-1232
 info@diequa.com
 www.diequa.com

SEE OUR AD
P17

Drive Lines Technologies Ltd

Duff Norton Australia
 Dunkermotoren USA Inc.
 EM Gear / Dae Seong Gear
 Electronic Machine Parts
 Emerson Industrial Automation - Drives & Motor
 Emerson Power Transmission
 Essential Power Transmission Pvt. Ltd.

Excel Gear, Inc.

11865 MAIN STREET, ROSCOE, IL 61073
 Phone: 815-623-3414
 Fax: 815-623-3314
chinn@excelsgear.com
www.excelsgear.com

SEE OUR AD
P22

Plastock - Putnam Precision Molding, Inc.
 Popular Mechanical Works
 Portescap
 Power Engineering and Manufacturing
 Power Transmission Engineers
 Precipart
 Precision Microdrives Limited
 QTC Metric Gears
 Quality Reducer Service
 Quality Transmission Components
 RJ Link International, Inc.
 Renk Test Systems
 Rex Engineering Corp.
 Ringball Corporation
 Rockwell Automation
 Rowland Co., The

SEW-Eurodrive

1295 OLD SPARTANBURG HWY., LYMAN, SC 29635
 Phone: (864) 439-7537
 Fax: (864) 439-7830
www.seweurodrive.com

SEE OUR AD
INSIDE BACK COVER**SIPCO-MLS**

Sallex Machine Tools
 Sam Gears India Pvt.Ltd
 Sesame Motor Corp.
 Setco Precision Spindles, Slides & Service
 Siemens Energy & Automation
 Siemens Industry, Inc.
 Sinotech
 Siti Spa Riduttori
 Sokhi Heli-Wom Gears Pvt. Ltd.
 Source Engineering Inc.
 Spencer Pettus
 Spline Gauges
 Spn Schwaben Praezision
 Star Gears

SEE OUR AD
P29**Exlar Corporation**

FMC Engineering
 Fairchild Industrial Products Co.
 Framo Morat Inc.
 GAM Gear
 GKN Driveline
 GMB Associates
 Gayatri Gear Industries
 Ghatge Patil Industries
 Gleason K2 Plastics
 Groschopp Inc.
 HPB Motion Control Co. Ltd.
 Hallmark Industries Inc.
 Hangzhou Xingda Machinery Co. Ltd.
 Harmonic Drive (Canada)
 Haumea Srl
 Henan Contrust Gear Transmission Co., Ltd.
 Hoffmann Technics Ag
 Houston Pump and Gear
 IBT, Inc

IDC-USA

933 WESTERN DRIVE, INDIANAPOLIS, IN 46241
 Phone: (317) 244-9200
 Fax: (317) 244-4600
sswaim@idc-usa.com
www.IDC-USA.com

ITW Heartland

Industrial Jig & Fixture
 JVL Industri Elektronik A/S
 Jahnelt - Kestermann Gmbh & Co. Kg
 K+S Services
 Kamar Industries
 LEESON Electric

SEE OUR AD
P15**Lafert North America**

5620 KENNEDY RD.
 MISSISSAUGA ON L4Z 2A9
 CANADA
 Phone: (905) 629-1939 or toll free (800) 661-6413
 Fax: (905) 629-2852
ptsales@lafertna.com
www.lafertna.com

Marswell Engineering Ltd.
 Maxon Precision Motors Inc
 Midwest Gear & Tool, Inc.
 Midwest Motion Products
 Mijno Precision Gearing
 Minsk Gear Works
 Motion Industries
 Moventas Ltd.
 NAC Harmonic Drive
 Niebuhr Gears

Ningbo Zhongyi Hydraulic Motor Co. Ltd.

NINGBO ZHENHAI ECONOMIC DEVELOPMENT ZONE
 ROAD 88, ITALY
 NINGBO
 CHINA
 Phone: +(86) 574-86261172-800
 Fax: +(86) 574-86288064
sales@zihyd.com
www.zihyd.com

SEE OUR AD
P33**Nord Drivesystems**

Norwin Electronics Limited
 Ondrives Ltd
 Onvio LLC
 Ormec
 P. G. DRIVE
 PIC Design
 PTD Outlet: Power Transmission Distributors
 Palmer Johnson Power Systems
 Parker Hannifin Electromechanical Automation Divis
 Performance Gear Systems, Inc.
 Phytion, Inc.

Sterling Instrument

2101 JERICHO TURNPIKE, NEW HYDE PARK, NY 11040
 Phone: (516) 328-3300
 Fax: (516) 326-8827
sdp-sisupport@sdp-si.com
www.sdp-si.com

SEE OUR AD
BACK COVER
P42,45**Stober Drives, Inc.****Stock Drive Products**

2101 JERICHO TURNPIKE, NEW HYDE PARK, NY 11040
 Phone: (516) 328-3300
 Fax: (516) 326-8827
sdp-sisupport@sdp-si.com
www.sdp-si.com

SEE OUR AD
BACK COVER
P35,40**Sumitomo Machinery Corp. of America**

Supreme Gear Co.
 T.E.A. Machine Components
 TVT America, Inc.
 Taiwan Precision Gear Corp.
 Team Industries
 TelcoMotion
 Toledo Gearmotor A Bluffton Motor Works Company
 Tolomatic, Inc.
 Tool Masters India
 Torque Transmission
 Transply Inc.
 Tristate Bearing & Supply Co. Inc.
 Triumph Gear Systems - Acr Industries
 Trojan Gear Inc.
 VL Motion Systems Inc.

Var-Spe Variatori Oleodinamici

WEG
 WMH Transmissions Ltd
 WPT Power Corporation
 Wittenstein (formerly alpha gear drives)

Worldwide Electric Corp.

1 GROVE ST. #201B
 PITTSFORD, NY 14534
 Phone: (800) 808-2131
 Fax: (800) 711-1616
www.worldwideelectric.net

SEE OUR AD
P34**Wyko - London & Overseas Supplies**

Xtek, Inc.
 Xuzhou BeiLai Engineering Machinery Co., Ltd
 ZRIME
 ZZN Transmission Plant
 Zero-Max
 pylon Gears (Pty) Ltd

GEAR MANUFACTURING SERVICES

ABL Products Incorporated
 ASI Technologies Inc.
 Accent Bearings Co. Inc.
 Accurate Gear and Machine, Inc.
 Ace World Companies
 Acme Gear Co.
 Acorn Industrial Services
 Agro Engineers
 Allen Gears Ltd.
 Allied Gear Co.
 Allied Specialty Precision Inc.
 American Gear & Engineering
 American Gear, Inc.
 American Plastics Depot
 American Swiss Products Co., Inc.
 Ametric / American Metric Corporation
 Ancon Gear & Instrument Corp.
 Ascent Precision Gear Corporation
 Atlanta Gear Works, Inc
 Autoparts Solutions PvtLtd
 Avion Technologies Inc.
 B&B Manufacturing, Inc.

B&R Machine and Gear Corp.

4809 U.S. HWY. 45
 SHARON TN 38255
 Phone: (731) 456-2636 or (800) 238-0651
 Fax: (731) 456-3073
inquiry@brgear.com
www.brgear.com

SEE OUR AD
P9**BC Gear Inc**

BC Manufacturing
 Bearing Service Company
 Beaver Aerospace and Defense Inc.

Beyta Gear Services

ON230 COUNTY FARM ROAD
 WINFIELD, IL 60190
 Phone: (630) 209-1652
chuck@beytagear.com
www.beytagear.com

SEE OUR AD
P88**Bharat Gears Ltd.**

Brelie Gear Company, Inc
 Brevini Power Transmission – Canada



**Established, Tested,
and Trusted.**

*Using technology & innovation to meet
your needs – now and into the future.*

765-759-2128 • info@brevinigeared.com
brevinigeared.com

Brevini Wind USA

2400 N. PRIORITY WAY
YORKTOWN, IN 47396
Phone: (765) 759-2128
Fax: (765) 759-4728
dale.harder@brevini.com
www.breviniwind.com

SEE OUR AD
P16,41,43,44

Broadway Gear
Buffalo Gear, Inc.
Butler Gear
C-B Gear & Machine
Calicut Engineering Works Limited
Carnes-Miller Gear Co., Inc.
Cattini & Figlio S.r.l.
Central Gear & Machine
Certified Reducer Builders Inc
Chenta USA

Circle Gear & Machine Co.

1501 S. 55TH COURT
CICERO, IL 60804
Phone: (708) 652-1000
Fax: (708) 652-1100
cirgeared@circlegear.com
www.circlegear.com

SEE OUR AD
P25

Clark Gear Works, Inc.
Clarke Engineering Inc. (Clarke Gear Co.)
Cleveland Gear Co.
Cloyes Gear & Products Inc.
Cogmatic, Inc.
Columbia Gear Corp.
Commercial Gear & Sprocket Co. Inc.

Cone Drive

240 EAST 12TH STREET
TRAVERSE CITY, MI 49685-0272
Phone: (888) 994-2663
Fax: (888) 907-2663
orders@conedrive.com
www.conedrive.com

SEE OUR AD
P39

Cross + Morse
Curtis Machine Co. Inc.
Custom Machine & Tool Co. Inc.
D G Steel & Son Engineering Ltd.
Dalton Bearing Service, Inc.
Davall Gears Ltd.
David Brown
Delroyd Worm Gear
Delta Gear Company
Delta Gear Corp.

Designatronics, Inc.

2101 JERICHO TURNPIKE, NEW HYDE PARK, NY 11040
Phone: (516) 328-3300
Fax: (516) 326-8827
info@designatronics.com
www.designatronics.com

SEE OUR AD
BACK COVER
**P34,35,
40,42,45**

Drive Lines Technologies Ltd
EM Gear / Dae Seong Gear
Electronic Machine Parts

Excel Gear, Inc.

11865 MAIN STREET, ROSCOE, IL 61073
Phone: 815-623-3414
Fax: 815-623-3314
chinn@excelgear.com
www.excelgear.com

SEE OUR AD
P22

FMC Engineering

Forest City Gear Co.

11715 MAIN STREET
ROSCOE, IL 61073
Phone: (815) 623-2168
Fax: (815) 623-6620
rmikel@fcgear.com
www.fcgear.com

SEE OUR AD
P13

GKN Driveline
GMB Associates
Gajra Gears Pvt. Ltd.
Gayatri Gear Industries
Gear Design & Service Pty. Ltd.
Gear Master Inc.
GearVisions, Inc.
Gleason K2 Plastics
Havlik Gear
Hayes Manufacturing Inc.
Hoffmann Technics Ag
Houston Pump and Gear
IBT, Inc
ITW Heartland
Industrial Jig & Fixture
Jahnel - Kestermann Gmbh & Co. Kg
Kamar Industries
Kinefac Corporation
Kleiss Gears, Inc.
MT Tool & Manufacturing
Magnum Manufacturing
Marswell Engineering Ltd.

Martin Sprocket & Gear

3100 SPROCKET DRIVE, ARLINGTON, TX 76015
Phone: (817) 258-3000
Fax: (817) 258-3333
mail@martinsprocket.com
www.martinsprocket.com

SEE OUR AD
P31

Mijno Precision Gearing
Mini-Broach Machine Company
Minsk Gear Works
Moventas Ltd.
New Allenberry Works (Deepak Industries Ltd.)
Niebuhr Gears
Nissei Corporation of America
Ontario Gear and Spline
Onvio LLC
P. G. DRIVE
PIC Design
PTD Outlet: Power Transmission Distributors
Performance Gear Systems, Inc.
Popular Mechanical Works
Power Engineering and Manufacturing
Pragati Transmission Pvt Ltd
Precipart
Precision Screw Thread
Precision Technologies Group (PTG) Ltd.
Pulley Manufacturers International Inc.
QTC Metric Gears
Quality Reducer Service
RJ Link International, Inc.
Rave Gears LLC
Renk Test Systems
Ronson Gears Pty. Ltd.
Rotek
Rush Gears Inc.
SIPCO-MLS
ST Gear & Machine LLC
Sam Gears India Pvt.Ltd
Schafer Industries
Shivam Autotech Ltd.
Sokhi Heli-Wom Gears Pvt. Ltd.
Spencer Pettus
Spn Schwaben Praezision
Sprockets Australia Pty. Ltd.
Steelmans Broaches Pvt Ltd

Sterling Instrument

2101 JERICHO TURNPIKE, NEW HYDE PARK, NY 11040
Phone: (516) 328-3300
Fax: (516) 326-8827
sdp-sisupport@sdp-si.com
www.sdp-si.com

SEE OUR AD
BACK COVER
P42,45**Stock Drive Products**

2101 JERICHO TURNPIKE, NEW HYDE PARK, NY 11040
Phone: (516) 328-3300
Fax: (516) 326-8827
sdp-sisupport@sdp-si.com
www.sdp-si.com

SEE OUR AD
BACK COVER
P35,40

Suhner Manufacturing Corp.
Supreme Gear Co.
Suzhou Asia Pacific Metal Co., Ltd.
Taiwan Precision Gear Corp.
Team Industries
Toledo Gearmotor A Bluffton Motor Works Company
Tool Masters India
Trojon Gear Inc.
Unigear Industries
VCST LP
VW Broaching Service Inc.
Vision Quality Components, Inc
WEG
WMH Transmissions Ltd
Wyko - London & Overseas Supplies
ZRIME
ZZN Transmission Plant
pylon Gears (Pty) Ltd

GEARS

ABL Products Incorporated
ASI Technologies Inc.
AST Bearings
ATA Gears Ltd.
Accent Bearings Co. Inc.
Accurate Gear and Machine, Inc.
Acme Gear Co.
Aero Gear Inc.
Agro Engineers
Akgears, LLC
Akron Gear and Engineering
Allen Gears Ltd.
Allied Gear Co.
Allied Specialty Precision Inc.
American Gear & Engineering
American Gear, Inc.
American Plastics Depot
American Swiss Products Co., Inc.
Ameridrives Power Transmission
Ametric / American Metric Corporation
Ancon Gear & Instrument Corp.
Andantex USA Inc.
Area Distributors Inc.

Arrow Gear Co.

2301 CURTISS STREET
DOWNERS GROVE, IL 60515
Phone: (630) 969-7640
Fax: (630) 969-0253
quote@arrowgear.com
www.arrowgear.com

SEE OUR AD
P5

Ascent Precision Gear Corporation
Atlanta Drive Systems Inc.
Atlanta Gear Works, Inc
Autoparts Solutions PvtLtd
Avion Technologies Inc.
B&B Manufacturing, Inc.

B&R Machine and Gear Corp.

4809 U.S. HWY. 45
SHARON TN 38255
Phone: (731) 456-2636 or (800) 238-0651
Fax: (731) 456-3073
inquiry@brgear.com
www.brgear.com

SEE OUR AD
P9

BC Gear Inc
BC Manufacturing

BDI - Bearing Distributors Inc.

Baldor Electric Company

5711 R.S. BOREHAM, JR. ST.
P.O. BOX 2400
FORT SMITH, AR 72901
Phone: (479) 646-4711
Fax: (479) 648-5792
www.baldor.com

SEE OUR AD
P21

Bearings Limited

Beaver Aerospace and Defense Inc.

Befared

Beijing THC Limited

Bevel Gears India Pvt. Ltd.

Bharat Gears Ltd.

Bison Gear and Engineering Corp.

Bonfiglioli Riduttori S.p.A.

Boston Gear

Brad Foote Gear Works, Inc

Brelie Gear Company, Inc

Brevini Power Transmission - Canada

Brevini USA



**Established, Tested,
and Trusted.**

*Using technology & innovation to meet
your needs - now and into the future.*

765-759-2128 • info@brevinegear.com

brevinegear.com

Brevini Wind USA

2400 N. PRIORITY WAY
YORKTOWN, IN 47396
Phone: (765) 759-2128
Fax: (765) 759-4728
dale.harder@brevini.com
www.breviniwind.com

SEE OUR AD
P16,41,43,44

Brewer Machine & Gear Co.

Broadway Gear

Brother Gearmotors

200 CROSSING BLVD.
BRIDGEWATER NJ 08807
Phone: (866) 523-6283
gearmotors@brother.com
www.brother-usa.com

SEE OUR AD
P23

Buffalo Gear, Inc.

Butler Gear

C&U Americas, LLC

45901 FIVE MILE ROAD
PLYMOUTH, MI 48170
Phone: (734) 656-0260
Fax: (734) 656-0261
contact@cubearing.com
www.cubearing.com

SEE OUR AD
P32

C-B Gear & Machine

CIMA S.p.A.

Calicut Engineering Works Limited

Capstan Atlantic

Carnes-Miller Gear Co., Inc.

Cattini & Figlio S.r.l.

Central Gear & Machine

Certified Reducer Rebuilders Inc

Chenta USA

Chongqing Rainbow M&E Co., Ltd

Circle Gear & Machine Co.

1501 S. 55TH COURT
CICERO, IL 60804
Phone: (708) 652-1000
Fax: (708) 652-1100
circular@circlegear.com
www.circlegear.com

SEE OUR AD
P25

Clark Gear Works, Inc.

Clarke Engineering Inc. (Clarke Gear Co.)

Cleveland Gear Co.

Cloyes Gear & Products Inc.

Cogmatic, Inc.

Columbia Gear Corp.

Commercial Gear & Sprocket Co. Inc.

Cone Drive

240 EAST 12TH STREET
TRAVERSE CITY, MI 49685-0272
Phone: (888) 994-2663
Fax: (888) 907-2663
orders@conedrive.com
www.conedrive.com

SEE OUR AD
P39

Cross + Morse

Curtis Machine Co. Inc.

Custom Gear & Machine Inc.

Custom Machine & Tool Co. Inc.

D G Steel & Son Engineering Ltd.

D&D Intl. Corp.

Dalton Bearing Service, Inc.

Davall Gears Ltd.

David Brown

DePe Gear Company Ltd

Delroyd Worm Gear

Delta Gear Company

Delta Gear Corp.

Delta Research Corp.

Designatronics, Inc.

2101 JERICHO TURNPIKE, NEW HYDE PARK, NY 11040
Phone: (516) 328-3300
Fax: (516) 326-8827
info@designatronics.com
www.designatronics.com

SEE OUR AD
BACK COVER
P34,35,
40,42,45

Drive Lines Technologies Ltd

Dunkermotoren USA Inc.

EM Gear / Dae Seong Gear

Electronic Machine Parts

Emerson Power Transmission

Essential Power Transmission Pvt. Ltd.

Excel Gear, Inc.

11865 MAIN STREET, ROSCOE, IL 61073
Phone: 815-623-3414
Fax: 815-623-3314
chinn@excelgear.com
www.excelgear.com

SEE OUR AD
P22

FMC Engineering

First Gear Engineering & Technology

7606 FREEDOM WAY
FORT WAYNE, IN 46818
Phone: (260) 490-3238
Fax: (260) 490-4093
greg@first-gear.com
www.first-gear.com

SEE OUR AD
P11**Forest City Gear Co.**

11715 MAIN STREET
ROSCOE, IL 61073
Phone: (815) 623-2168
Fax: (815) 623-6620
rmikel@fcgear.com
www.fcgear.com

SEE OUR AD
P13

Framo Morat Inc.

GKN Driveline

GMB Associates

GMN Bearing Usa, Ltd.

Gajra Gears Pvt. Ltd.

Gayatri Gear Industries

Gear Design & Service Pty. Ltd.

Gear Manufacturing Inc.

Gear Master Inc.

GearVisions, Inc.

Gleason K2 Plastics

Groschopp Inc.

Hangzhou Xingda Machinery Co. Ltd.

Havlik Gear

Hayes Manufacturing Inc.

Henan Contrust Gear Transmission Co., Ltd.

Hoffmann Technics Ag

Houston Pump and Gear

IBT, Inc

IDC-USA

933 WESTERN DRIVE, INDIANAPOLIS, IN 46241
Phone: (317) 244-9200
Fax: (317) 244-4600
sswaim@idc-usa.com
www.IDC-USA.com

SEE OUR AD
P29

IG Watteeuw

ITW Heartland

Industrial Jig & Fixture

Industrial Pulley & Machine Co, Inc.

Intech Corporation

Involute Simulation Software Inc.

JVL Industri Elektronik A/S

Jahnel - Kestermann GmbH & Co. Kg

Kamar Industries

Kaydon Corporation Bearings Division

Kleiss Gears, Inc.

LYC North America Inc

MT Tool & Manufacturing

Magnum Manufacturing

Marswell Engineering Ltd.

Martin Sprocket & Gear

3100 SPROCKET DRIVE, ARLINGTON, TX 76015
Phone: (817) 258-3000
Fax: (817) 258-3333
mail@martinsprocket.com
www.martinsprocket.com

SEE OUR AD
P31**McInnes Rolled Rings**

1533 EAST 12TH STREET
ERIE, PA 16511
Phone: (814) 459-4495
Fax: (814) 459-8443
sales@mcrings.com
www.mcinnrolledrings.com

SEE OUR AD
P27

Midwest Gear & Tool, Inc.

Midwest Motion Products

Mijno Precision Gearing

Mini Gears (Stockport) Ltd.

Mini-Broach Machine Company

Minsk Gear Works

Motion Industries

Moventas Ltd.

Netshape Technologies, Inc.

New Allenberry Works (Deepak Industries Ltd.)

Niebuhr Gears

Nisse Corporation of America

Nu-Teck Couplings Pvt. Ltd

Ongears - Ondrives Export Gears

Ontario Gear and Spline

P. G. DRIVE

PIC Design

PTD Outlet: Power Transmission Distributors

Performance Gear Systems, Inc.

Plastock - Putnam Precision Molding, Inc.

Popular Mechanical Works

Portescap

Pragati Transmission Pvt Ltd

Precipart

Precision Screw Thread

Precision Technologies Group (PTG) Ltd.

Pulley Manufacturers International Inc.

QTC Metric Gears

Supplying North America

Modules
0.5-10

Customized Design
www.qtcgears.com



Designatronics inc.

QTC Metric Gears

2101 JERICHO TURNPIKE, NEW HYDE PARK, NY 11040

Phone: (516) 437-6700

Fax: (516) 328-3343

qtcsupport@qtcgears.com

www.qtcgears.com

SEE OUR AD
P45

Quality Bearings & Components

RBI Bearing Inc.

RJ Link International, Inc.

Rave Gears LLC

Ringball Corporation

Ritbearing Corp.

Ronson Gears Pty. Ltd.

Rotek

Rush Gears Inc.

SIPCO-MLS

SKF USA Inc.

890 FORTY FOOT ROAD, LANSDALE, PA 19446

Phone: (267) 436-6000

www.skf.com

SEE OUR AD
P3

ST Gear & Machine LLC

Sallex Machine Tools

Sam Gears India Pvt. Ltd.

Schaeffler Group USA, Inc

308 SPRINGHILL FARM ROAD

FORT MILL, SC 29715

Phone: (803) 548-8500

Fax: (803) 548-8599

www.schaeffler.us

SEE OUR AD
P7

Schafer Industries

Shivam Autotech Ltd.

Sinotech

Siti Spa Riduttori

Sokhi Heli-Wom Gears Pvt. Ltd.

Source Engineering Inc.

South Bend Gear LLC

Spencer Pettus

Spline Gauges

Spn Schwaben Praezision

Sprockets Australia Pty. Ltd.

SI Sterling Instrument

Your Partner in Innovation

Engineered Precision
Gear Solutions

Large Production Capacity
www.sdp-si.com



Designatronics inc.

Sterling Instrument

2101 JERICHO TURNPIKE, NEW HYDE PARK, NY 11040

Phone: (516) 328-3300

Fax: (516) 326-8827

sdp-sisupport@sdp-si.com

www.sdp-si.com

SEE OUR AD
BACK COVER
P42,45

Stock Drive Products

2101 JERICHO TURNPIKE, NEW HYDE PARK, NY 11040

Phone: (516) 328-3300

Fax: (516) 326-8827

sdp-sisupport@sdp-si.com

www.sdp-si.com

SEE OUR AD
BACK COVER
P35,40

Suhner Manufacturing Corp.
Sumitomo Machinery Corp. of America
Supreme Gear Co.
Suzhou Asia Pacific Metal Co., Ltd.
T.E.A. Machine Components
Taiwan Precision Gear Corp.
Team Industries
Toledo Gearmotor A Bluffton Motor Works Company
Tool Masters India
Torque Transmission
Transply Inc.
Tristate Bearing & Supply Co. Inc.
Triumph Gear Systems - Acr Industries
Trojon Gear Inc.
Tsubaki of Canada Limited
Unigear Industries
VCST LP
VW Broaching Service Inc.
Venture Products International
Vision Quality Components, Inc
WMH Transmissions Ltd
Wyko - London & Overseas Supplies
Xtek, Inc.
Yieh Chen Machinery (Six Star Group)
ZRIME
ZZN Transmission Plant
Zero-Max
pylon Gears (Pty) Ltd

INDUSTRIAL HARDWARE AND MACHINE PARTS

All Metric Small Parts (aMsp)

American Plastics Depot

Daemar Inc.

Delta Gear Company

Designatronics, Inc.

2101 JERICHO TURNPIKE, NEW HYDE PARK, NY 11040

Phone: (516) 328-3300

Fax: (516) 326-8827

info@designatronics.com

www.designatronics.com

SEE OUR AD
BACK COVER
P34,35,
40,42,45

Gear Master Inc.

Hi-Grade Inc.

Houston Pump and Gear

Martin Sprocket & Gear

3100 SPROCKET DRIVE, ARLINGTON, TX 76015

Phone: (817) 258-3000

Fax: (817) 258-3333

mail@martinsprocket.com

www.martinsprocket.com

SEE OUR AD
P31

Motion Industries

Netshape Technologies, Inc.

Powermach Import & Export Co.,Ltd

Premier Udyog

SKG Enterprises

Sterling Instrument

2101 JERICHO TURNPIKE, NEW HYDE PARK, NY 11040

Phone: (516) 328-3300

Fax: (516) 326-8827

sdp-sisupport@sdp-si.com

www.sdp-si.com

SEE OUR AD
BACK COVER
P42,45

Stock Drive Products

2101 JERICHO TURNPIKE, NEW HYDE PARK, NY 11040

Phone: (516) 328-3300

Fax: (516) 326-8827

sdp-sisupport@sdp-si.com

www.sdp-si.com

SEE OUR AD
BACK COVER
P35,40

LINEAR MOTION DEVICES

AGI Automation Components
AISCO Industrial Couplings
AST Bearings
Accent Bearings Co. Inc.
Acorn Industrial Services
Advanced Control Systems Corporation

Aerotech Inc.
Amacoil, Inc.
Ametric / American Metric Corporation
Andantex USA Inc.
Area Distributors Inc.
Atlanta Drive Systems Inc.
BDI - Bearing Distributors Inc.

Baldor Electric Company

5711 R.S. BOREHAM, JR. ST.

P.O. BOX 2400

FORT SMITH, AR 72901

Phone: (479) 646-4711

Fax: (479) 648-5792

www.baldor.com

SEE OUR AD
P21

Beaver Aerospace and Defense Inc.

Bishop-Wisecarver Corp.

CUI Inc

Certified Reducer Builders Inc

Clarke Engineering Inc. (Clarke Gear Co.)

Custom Gear & Machine Inc.

Custom Sensors & Technologies

Dalton Bearing Service, Inc.

Danaher Motion and Thomson

Davall Gears Ltd.

David Brown

Del-Tron Precision Inc.

Designatronics, Inc.

2101 JERICHO TURNPIKE, NEW HYDE PARK, NY 11040

Phone: (516) 328-3300

Fax: (516) 326-8827

info@designatronics.com

www.designatronics.com

SEE OUR AD
BACK COVER
P34,35,
40,42,45

DieQua Corp.

180 COVINGTON DRIVE, BLOOMINGDALE, IL 60108

Phone: (630) 980-1133

Fax: (630) 980-1232

info@diequa.com

www.diequa.com

SEE OUR AD
P17

Discovery Technology International, Inc.

Dn Sales Australia

Drive Lines Technologies Ltd

Duff Norton Australia

Dunkermotoren USA Inc.

Durabond Slides

Dynamic Structures and Materials, LLC

Dynex/Rivett Inc.

Emerson Industrial Automation - Drives & Motor

Exlar Corporation

FMC Engineering

Festo Corporation

Framo Morat Inc.

HPB Motion Control Co. Ltd.

Hallmark Industries Inc.

Houston Pump and Gear

IAI America, Inc.

IBT, Inc

IDC-USA

933 WESTERN DRIVE, INDIANAPOLIS, IN 46241

Phone: (317) 244-9200

Fax: (317) 244-4600

sswaim@idc-usa.com

www.IDC-USA.com

SEE OUR AD
P29

Industrial Clutch Parts Ltd.

Intellidrives, Inc

International Distribution Alliance, Inc. (IDA, In

InvenSense

K+S Services

LEESON Electric

Mavilor Motors, S.a.

Midwest Motion Products

Mitsubishi Electric Automation, Inc.

Modern Linear Inc.

Motion Industries

North American Clutch Corp. (noram)

Novotec Argentina SRL

Ondrives Ltd

Ormec

Orttech
PI (Physik Instrumente) L.P. Piezo Actuator Nano
PIC Design
PTD Outlet: Power Transmission Distributors
Parker Hannifin Electromechanical Automation Divis
Performance Gear Systems, Inc.
Phytron, Inc.
Portescap
Precipart
Precision Screw Thread
Precision Technologies Group (PTG) Ltd.
Rex Engineering Corp.
Ringball Corporation
Rockwell Automation
Rowland Co., The

SEW-Eurodrive

1295 OLD SPARTANBURG HWY., LYMAN, SC 29635
Phone: (864) 439-7537
Fax: (864) 439-7830
www.seweurodrive.com

SEE OUR AD
INSIDE BACK COVER**SIPCO-MLS****SKF USA Inc.**

890 FORTY FOOT ROAD, LANSDALE, PA 19446
Phone: (267) 436-6000
www.skf.com

SEE OUR AD
P3**Schaeffler Group USA, Inc**

308 SPRINGHILL FARM ROAD
FORT MILL, SC 29715
Phone: (803) 548-8500
Fax: (803) 548-8599
www.schaeffler.us

SEE OUR AD
P7**Serapid Inc.****Servometer****Sesame Motor Corp.****Siemens Industry, Inc.****Specialty Motions, Inc.****Spn Schwaben Praezision****Steinmeyer Inc.****Sterling Instrument**

2101 JERICHO TURNPIKE, NEW HYDE PARK, NY 11040
Phone: (516) 328-3300
Fax: (516) 326-8827
sdp-sisupport@sdp-si.com
www.sdp-si.com

SEE OUR AD
BACK COVER
P42,45**Stock Drive Products**

2101 JERICHO TURNPIKE, NEW HYDE PARK, NY 11040
Phone: (516) 328-3300
Fax: (516) 326-8827
sdp-sisupport@sdp-si.com
www.sdp-si.com

SEE OUR AD
BACK COVER
P35,40**T.E.A. Machine Components****Technico****Tecnotion BV****TelcoMotion****Tolomatic, Inc.****Tristate Bearing & Supply Co. Inc.****VL Motion Systems Inc.****WEG****WMH Transmissions Ltd****Warner Linear****Whittet-Higgins Company****Wittenstein (formerly alpha gear drives)****Wyko - London & Overseas Supplies****Yaskawa America, Inc.**

DRIVES & MOTORS DIVISION
2121 NORMAN DRIVE SOUTH
WAUKEGAN, IL 60085
Phone: (800) 927-5292
Fax: (847) 887-7310
tom_kutcher@yaskawa.com
www.yaskawa.com

SEE OUR AD
P19**LUBRICATION****Acorn Industrial Services****Daubert Cromwell LLC****Hydraulic Problems ?, Inc.****Isel Inc.****SKF USA Inc.**

890 FORTY FOOT ROAD, LANSDALE, PA 19446
Phone: (267) 436-6000
www.skf.com

SEE OUR AD
P3**Schaeffler Group USA, Inc**

308 SPRINGHILL FARM ROAD
FORT MILL, SC 29715
Phone: (803) 548-8500
Fax: (803) 548-8599
www.schaeffler.us

SEE OUR AD
P7**Tristate Bearing & Supply Co. Inc.****MATERIALS****McInnes Rolled Rings**

1533 EAST 12TH STREET
ERIE, PA 16511
Phone: (814) 459-4495
Fax: (814) 459-8443
sales@mcrings.com
www.mcinnrolledrings.com

SEE OUR AD
P27**MOTORS****ASI Technologies Inc.****Accent Bearings Co. Inc.****Acorn Industrial Services****Advanced Control Systems Corporation****Aerotech Inc.****Allied Motion****Ametric / American Metric Corporation****Arc Systems, Inc****Area Distributors Inc.****Automation Direct**

3505 HUTCHINSON ROAD, CUMMING, GA 30040
Phone: (800) 633-0405
Fax: (770) 844-4212
sales@automationdirect.com
www.automationdirect.com

SEE OUR AD
INSIDE FRONT COVER**BDI - Bearing Distributors Inc.****Baldor Electric Company**

5711 R.S. BOREHAM, JR. ST.
P.O. BOX 2400
FORT SMITH, AR 72901
Phone: (479) 646-4711
Fax: (479) 648-5792
www.baldor.com

SEE OUR AD
P21**Bison Gear and Engineering Corp.****Bodine Electric Company****Bonfiglioli Riduttori S.p.A.****Bonfiglioli USA****Boston Gear****Buehler Motor, Inc.****Cone Drive**

240 EAST 12TH STREET
TRAVERSE CITY, MI 49685-0272
Phone: (888) 994-2663
Fax: (888) 907-2663
orders@conedrive.com
www.conedrive.com

SEE OUR AD
P39**Conroll Corporation****Custom Motors Inc.****Custom Sensors & Technologies****Cutes Corporation****D&D Intl. Corp.****Dalton Bearing Service, Inc.****Danaher Motion and Thomson****Davall Gears Ltd.****David Brown****Designatronics, Inc.**

2101 JERICHO TURNPIKE, NEW HYDE PARK, NY 11040
Phone: (516) 328-3300
Fax: (516) 326-8827
info@designatronics.com
www.designatronics.com

SEE OUR AD
BACK COVER
P34,35,
40,42,45**DieQua Corp.**

180 COVINGTON DRIVE, BLOOMINGDALE, IL 60108
Phone: (630) 980-1133
Fax: (630) 980-1232
info@diequa.com
www.diequa.com

SEE OUR AD
P17**Discovery Technology International, Inc.****Drive Lines Technologies Ltd****Duff Norton Australia****Dunkermotoren USA Inc.****Dynex/Rivett Inc.****Electro Static Technology****Electronic Machine Parts****Elektrim Motors****Emerson Industrial Automation - Drives & Motor****Emerson Power Transmission****Exlar Corporation****Festo Corporation****GMB Associates****Groschopp Inc.****HPB Motion Control Co. Ltd.****Hallmark Industries Inc.****Hansen Motor Corporation****Hoffmann Technics Ag****IBT, Inc****IDC-USA**

933 WESTERN DRIVE, INDIANAPOLIS, IN 46241
Phone: (317) 244-9200
Fax: (317) 244-4600
sswaim@idc-usa.com
www.IDC-USA.com

SEE OUR AD
P29**Intellidrives, Inc****JVL Industri Elektronik A/S****K+S Services****LEESON Electric****Lafert North America**

5620 KENNEDY RD.
MISSISSAUGA ON L4Z 2A9
CANADA
Phone: (905) 629-1939 or toll free (800) 661-6413
Fax: (905) 629-2852
ptsales@lafertna.com
www.lafertna.com

SEE OUR AD
P15**MT Tool & Manufacturing****Mark Elektriks****Mavilor Motors, S.a.****Maxon Precision Motors Inc****Midwest Motion Products****Mitsubishi Electric Automation, Inc.****Motion Industries****Navyug Electric Motors & Pumps Ltd****New Power Electric (USA) LLC****Norwin Electronics Limited****Novotec Argentina SRL****Onvio LLC****OrmeC****PI (Physik Instrumente) L.P. Piezo Actuator Nano****PTD Outlet: Power Transmission Distributors****Parker Hannifin - SSD Drives Div.****Parker Hannifin Electromechanical Automation Divis****Performance Gear Systems, Inc.****Phytron, Inc.****Popular Mechanical Works****Portescap****Precision Microdrives Limited****Rex Engineering Corp.****Rockwell Automation****SEW-Eurodrive**

1295 OLD SPARTANBURG HWY., LYMAN, SC 29635
Phone: (864) 439-7537
Fax: (864) 439-7830
www.seweurodrive.com

SEE OUR AD
INSIDE BACK COVER**SIPCO-MLS****SKF USA Inc.**

890 FORTY FOOT ROAD, LANSDALE, PA 19446
Phone: (267) 436-6000
www.skf.com

SEE OUR AD
P3

Schaeffler Group USA, Inc

308 SPRINGHILL FARM ROAD
FORT MILL, SC 29715
Phone: (803) 548-8500
Fax: (803) 548-8599
www.schaeffler.us

SEE OUR AD
P7**Schneider Electric Motion Competency Center**

Sesame Motor Corp.
Siemens Energy & Automation
Siemens Industry, Inc.
Sinotech
Siti Spa Riduttori
Source Engineering Inc.
Star Gears

Stock Drive Products

2101 JERICHO TURNPIKE, NEW HYDE PARK, NY 11040
Phone: (516) 328-3300
Fax: (516) 326-8827
sdp-sisupport@sdp-si.com
www.sdp-si.com

SEE OUR AD
BACK COVER
P35,40**Sumitomo Machinery Corp. of America**

TSS Rotterdam B.V.
TVT America, Inc.
Taiwan Precision Gear Corp.
Tecnotion BV
Teco Westinghouse
Tef - Cap Industries
TelcoMotion
Tolomatic, Inc.
Transply Inc.
VL Motion Systems Inc.
WEG
Wittenstein (formerly alpha gear drives)

Worldwide Electric Corp.

1 GROVE ST. #201B
PITTSFORD, NY 14534
Phone: (800) 808-2131
Fax: (800) 711-1616
www.worldwideelectric.net

SEE OUR AD
P34**Wyko - London & Overseas Supplies****Yaskawa America, Inc.**

DRIVES & MOTORS DIVISION
2121 NORMAN DRIVE SOUTH
WAUKEGAN, IL 60085
Phone: (800) 927-5292
Fax: (847) 887-7310
tom_kutcher@yaskawa.com
www.yaskawa.com

SEE OUR AD
P19**RESOURCES****AGMA**

Beyta Gear Services

Deutsche Messe AG

MESSEGELÄNDE
30521 HANNOVER
GERMANY
Phone: +(49) 511-89-0
Fax: +(49) 511-89-32626
www.messe.de

SEE OUR AD
P77

Randall Publications LLC

SEALS

Accent Bearings Co. Inc.
Acorn Industrial Services
All Metric Small Parts (aMsp)
Ametric / American Metric Corporation
Area Distributors Inc.
BDI - Bearing Distributors Inc.
Bearing Service Company
Centritec Seals, LLC
Certified Reducer Rebuilders Inc
Core Supply LLC
Dalton Bearing Service, Inc.
Darbar Belting
GMN Bearing Usa, Ltd.
Houston Pump and Gear
IBT, Inc

IDC-USA

933 WESTERN DRIVE, INDIANAPOLIS, IN 46241
Phone: (317) 244-9200
Fax: (317) 244-4600
sswaim@idc-usa.com
www.IDC-USA.com

SEE OUR AD
P29**MROSupply**

Motion Industries
Moventas Ltd.
PTD Outlet: Power Transmission Distributors
RUBENA a.s.

SKF USA Inc.

890 FORTY FOOT ROAD, LANSDALE, PA 19446
Phone: (267) 436-6000
www.skf.com

SEE OUR AD
P3**Smalley Steel Ring Company**

555 OAKWOOD ROAD, LAKE ZURICH, IL 60047
Phone: (847) 719-5900
Fax: (847) 719-5999
info@smalley.com
www.smalley.com

SEE OUR AD
P26

Wyko - London & Overseas Supplies
Zerelli Technologies Inc

SENSORS

Acorn Industrial Services
AeroScout Industrial
Akron Gear and Engineering
Allied Motion
Area Distributors Inc.

Automation Direct

3505 HUTCHINSON ROAD, CUMMING, GA 30040
Phone: (800) 633-0405
Fax: (770) 844-4212
sales@automationdirect.com
www.automationdirect.com

SEE OUR AD
INSIDE FRONT COVER**Axu S.r.l.**

BDI - Bearing Distributors Inc.
BEI Industrial Encoders
Binsfeld Engineering Inc.
Bison Gear and Engineering Corp.
CUI Inc
Conroll Corporation
Custom Sensors & Technologies
Dalton Bearing Service, Inc.
Drive Lines Technologies Ltd
Duff Norton Australia
Dunkermotoren USA Inc.
Electronic Machine Parts
FSI Technologies Inc.
Fagor Automation
Festo Corporation
Fife Corporation
GMB Associates
GP:50 Corporation
Great Northern Products Inc.
HBM
HEIDENHAIN Corporation
HPB Motion Control Co. Ltd.
IBT, Inc

IDC-USA

933 WESTERN DRIVE, INDIANAPOLIS, IN 46241
Phone: (317) 244-9200
Fax: (317) 244-4600
sswaim@idc-usa.com
www.IDC-USA.com

SEE OUR AD
P29

Industrial Clutch Parts Ltd.
Intellidrives, Inc
InvenSense
JVL Industri Elektronik A/S
K+S Services
Kavlico Corporation
Magtrol, Inc.
Marshall Wolf Automation Inc.
Maxon Precision Motors Inc
Mayr Corporation

Micronor Inc.

Midwest Motion Products
Motion Industries
Norwin Electronics Limited
Novotec Argentina SRL
PI (Physik Instrumente) L.P. Piezo Actuator Nano
Portescap
Potomac Electric
Precipart
Rdf Corporation
Rockwell Automation
Rowland Co., The

SKF USA Inc.

890 FORTY FOOT ROAD, LANSDALE, PA 19446
Phone: (267) 436-6000
www.skf.com

SEE OUR AD
P3**Schenck Trebel Corporation**

Sensor Developments, Inc
Sensor Products Inc.
Sensor Technology Ltd
Sinotech
Source Engineering Inc.
Stellar Technology, Inc.
Tef - Cap Industries
Transply Inc.
Wyko - London & Overseas Supplies
Xtek, Inc.

SOFTWARE**Excel Gear, Inc.**

11865 MAIN STREET, ROSCOE, IL 61073
Phone: 815-623-3414
Fax: 815-623-3314
chinn@excelgear.com
www.excelgear.com

SEE OUR AD
P22**Inolute Simulation Software Inc.**

Mark Elektriks
ZRIME

A. Fischer Phase Drives

4615 W. PRIME PARKWAY
MCHENRY, IL 60050-7037
Phone: (815) 385-3500
Fax: (815) 363-1641
sales@afischerphasedrives.com
www.afischerphasedrives.com

ABL Products Incorporated

3726 RIDGE ROAD
CLEVELAND, OH 44144
Phone: (216) 281-2400
Fax: (216) 281-7753
lesgicej@ablproducts.com
www.ablproducts.com

ABT Bearing

345 PRODUCTION DRIVE
SOUTH ELGIN, IL 60177
Phone: (800) 931-1860
Fax: (847) 931-9411
sales@abtbearing.com
www.abtbearing.com

Accent Bearings Co. Inc.

367-G S. ROHLWING ROAD
ADDISON, IL 60101
Phone: (630) 916-1930
Fax: (630) 916-7740
accentbrg@sbcglobal.net
www.accentbearing.com

Accurate Gear and Machine, Inc.

2864 BURTON AVE.
WATERLOO, IA 50703
Phone: (319) 233-1997
Fax: (319) 233-7677
sales@accurategear.com
accurategear.com

Ace World Companies

10200 JACKSBORO HIGHWAY
FORT WORTH, TX 76135
Phone: (817) 237-7700
Fax: (817) 237-7777
alberto@aceworldcompanies.com
www.aceworldcompanies.com

Acidon Equipos Indls Ltda

acicl@acicl.com.br
570 PAULO SP 05639120
BRAZIL
Phone: 551137433251
acicl@acicl.com.br
www.acicl.com.br

Acionac Indªstria E Comª©

eduardo@acionac.com.br
SÃO PAULO SP 02186-020
BRAZIL
Phone: +(55) 11 6954-6121
eduardo@acionac.com.br
www.acionac.com.br

Acme Gear Co.

130 WEST FOREST AVE.
ENGLEWOOD, NJ 07631
Phone: (201) 568-2245
Fax: (201) 568-0282
info@acmegear.com
www.acmegear.com

Acorn Industrial Services

UNIT A, DENBY WAY
HELLABY IND. EST.
ROTHERHAM SOUTH YORKSHIRE S66 8HR
UNITED KINGDOM
Phone: +(44) 0845-602-9946
Fax: +(44) 01709-789-988
www.acorn-ind.co.uk

ACS Motion Control

14700 28TH AVE N
SUITE 25
PLYMOUTH, MN 55447
Phone: (763) 559-7669
Fax: (763) 559-0110
sales@acsmotioncontrol.com
www.acsmotioncontrol.com

Adams Company

8040 CHAVENELLE ROAD
DUBUQUE, IA 52002
Phone: (563) 583-3591
Fax: (563) 583-8048
sales@theadamscompany.com
www.theadamscompany.com

Advanced Control Systems Corporation

35 CORPORATE PARK DRIVE
PEMBROKE, MA 02359
Phone: (781) 829-9228
Fax: (781) 829-9875
sales.desk@acsmotion.com
www.acsmotion.com

Advanced Test & Automation Inc.

641 MAIN STREET EAST MILTON
MILTON ONTARIO L9T 3J2
CANADA
Phone: (647) 477-6247
anthony.advancedta@gmail.com
www.advancedta.com

Aero Gear Inc.

1050 DAY HILL ROAD
WINDSOR, CT 06095
Phone: (860) 688-0888
Fax: (860) 285-8514
buygears@aerogear.com
aerogear.com

Aerocom Industries Inc.

1921 MILLER DRIVE
LONGMONT, CO 80501
Phone: (303) 776-4300
Fax: (303) 776-4723
toml@aerocom-industries.com
www.aerocom-industries.com

AeroScout Industrial

335 WILLOW STREET
NORTH ANDOVER, MA 01845
Phone: (888) 925-5570
Industrial@aeroscout.com
www.aeroscout.com/industrial

Aerotech Inc.

101 ZETA DRIVE
PITTSBURGH, PA 15238-2897
Phone: (412) 963-7470
Fax: (412) 963-7459
sales@aerotech.com
www.aerotech.com

AGI Automation Components

171 SPRING HILL RD
TRUMBULL, CT 06611
Phone: (203) 459-8345
Fax: (203) 459-5943
amerigrip@aol.com
www.agi-automation.com

AGMA

1001 N. FAIRFAX STREET, SUITE 500
ALEXANDRIA, VA 22314-1587
Phone: (703) 684-0211
Fax: (703) 684-0242
webmaster@agma.org
www.agma.org

Agro Engineers

E-3, INDUSTRIAL ESTATE
INDIA
KOTA RAJASTHAN 324007
INDIA
Phone: +(91)-744-2363799
Fax: +(91)-744-2360835
info@agroengineers.com
www.agroengineers.com

AISCO Industrial Couplings

701 RALPH LEMORANDE DR.
OCONTO FALLS, WI 54154
Phone: (920) 336-5111
Fax: (920) 336-2690
dan.zahn@aiscoinc.com
www.aiscoinc.com

Akgears, Llc

316 OAKWOOD DRIVE
SHOREVIEW, MN 55126
Phone: (651) 308-8899
Fax: (651) 486-2716
ak@akgears.com
www.akgears.com

Akron Gear and Engineering

501 MORGAN AVE.
AKRON, OH 44311
Phone: (800) 258-6608
Fax: (330) 773-9005
steve@akrongear.com
www.akrongear.com

All Metric Small Parts (aMsp)

2101 JERICHO TURNPIKE
NEW HYDE PARK, NY 11040
Phone: (516) 302-0107
Fax: (516) 326-8827
hrarum@aol.com
www.allmetricsmallparts.com

Allen Gears Ltd.

ATLAS WORKS
STATION ROAD
PERSHORE WORCESTERSHIRE WR10 2BZ
UNITED KINGDOM
Phone: +(44) 1386-552-211
Fax: +(44) 1386-554-491
sales@allengears.com
www.allengears.com

Allied Gear Co.

4901 W. ARTHINGTON ST.
CHICAGO, IL 60644
Phone: (773) 287-8742
Fax: (773) 287-4720
nt350@thealliedgearco.com
www.thealliedgearco.com

Allied Motion

23 INVERNESS WAY EAST
STE 150
ENGLEWOOD, CO 80113-5711
Phone: (303) 799-8520
ken.wyman@alliedmotion.com
catalog.alliedmotion.com

Allied Specialty Precision Inc.

815 E LOWELL AVE. P.O. BOX 543
MISHAWAKA, IN 46546
Phone: (574) 255-4718
Fax: (574) 255-4713
larry.delater@aspi-nc.com
www.aspi-nc.com

Amacoil, Inc.

PO BOX 2228
2100 BRIDGEWATER ROAD
ASTON, PA 19014
Phone: (610) 485-8300
Fax: (610) 485-2357
amacoil@amacoil.com
www.amacoil.com

Aman Transmission Co

info@amantransbelt.com
2475, AMAN HOUSE, OPP.NAVISHERY,
TAJPUR MOMINWAD, JAMALPUR,
AHMEDABAD GUJARAT 380001
INDIA
Phone: 0091-982 425 7006
Fax: 0091- 79 25395863
info@amantransbelt.com
www.amantransbelt.com

American Collars & Couplings, inc.

88 HUBBARD STREET
WINSTED, CT 06098
Phone: (860) 379-7043
Fax: (860) 379-7063
info@americancollars.com
www.americancollars.com

American Gear & Engineering

38200 ABRUZZI DR.
WESTLAND, MI 48185
Phone: (734) 595-6400
Fax: (734) 595-0149
agear@worldnet.att.net
www.americangeareng.com

American Gear, Inc.

P.O. BOX 156
910 SWANSON DR
PROPHETSTOWN, IL 61277
Phone: (815) 537-5111
Fax: (815) 537-2871
info@americangearinc.com
www.americangearinc.com

American Plastics Depot

10194 SW CONCHO COURT
TUALATIN, OR 97062-9570
Phone: (503) 885-2049
Fax: (877) 709-9790
sales@americanplasticsdepot.com
www.americanplasticsdepot.com

American Rotary Industrial Power Source

215 S PARK STREET
PORT WASHINGTON, WI 53074
Phone: (262) 268-7014
Fax: (262) 268-7015
info@americanrotary.com
www.americanrotary.com/home.php

American Swiss Products Co., Inc.

1987 JEFFERSON RD., WEST
PITTSFORD, NY 14534
Phone: (585) 292-1720
Fax: (585) 292-5525
sales@americanswiss.com
www.americanswiss.com

Ameridrives

1802 PITTSBURGH AVE.
ERIE, PA 16502
Phone: (814) 480-5000
Fax: (814) 453-5891
info@ameridrives.com
www.ameridrives.com

Ameridrives Power Transmission

1680 CORNELL RD.
GREEN BAY, WI 54313
Phone: (920) 593-2444
Fax: (920) 593-2440
info@altramotion.com
www.ameridrivespowertransmission.com

Ametric / American Metric Corporation

52 METRIC ROAD
LAURENS, SC 29360
Phone: (864) 876-2011
Fax: (864) 876-2566
marketing@ametric.com
www.ametric.com

Anaheim Automation, Inc.

910 EAST ORANGEFAIR LANE
ANAHEIM, CA 92801
Phone: (714) 992-6990
Fax: (714) 992-0471
info@anaheimautomation.com
www.anaheimautomation.com

Ancon Gear & Instrument Corp.

149 VERDI ST.
FARMINGDALE, NY 11735
Phone: (631) 694-5255
Fax: (631) 694-5056
info@ancongear.com
www.ancongear.com

Andantex USA Inc.

1705 VALLEY RD.
WANAMASSA, NJ 07712
Phone: (800) 713-6170
Fax: (732) 493-2949
info@andantex.com
www.andantex.com

Annflex Bellows & Compensators

D/21, GOKULDHAM SOCIETY, B/HUNION
BANK-SAMA BR.
POST-EME, SAMA, VADODARA
VADODARA GUJARAT 390008
INDIA
Phone: 0091 265 2714685
Fax: 0091 265 2781809
annbellow@hotmail.com
www.annflex.com

Applied Power Solutions
1718 WEST ARMITAGE COURT
ADDISON, IL 60101
Phone: (888) 277-9901
Fax: (630) 599-3001
chris.s@apscorp.com
apscorp.com

Arc Systems, Inc
2090 JOSHUAS PATH
HAUPPAUGE, NY 11788
Phone: (631) 582-8020
Fax: (631) 582-8038
mail@arcsystemsinc.com
www.arcsystemsinc.com

Area Distributors Inc.
61-02 31ST AVE.
WOODSIDE, NY 11377
Phone: (718) 726-9200
Fax: (718) 626-0712
mike@areadist.com
areadist.com

Arrow Gear Co.
2301 CURTISS STREET
DOWNERS GROVE, IL 60515
Phone: (630) 969-7640
Fax: (630) 969-0253
quote@arrowgear.com
www.arrowgear.com

SEE OUR AD
P5

Ascent Precision Gear Corporation
12180 S.E. CR137
JASPER, FL 32052
Phone: (386) 792-3215
Fax: (386) 792-3216
sales@ascentgear.com
www.ascentgear.com

Ashot Ashkelon Industries Ltd.
1 EZRA YESODI STREET
ASHKELON 78100
ISRAEL
Phone: +(972) 8-6721511
Fax: +(972) 8-6721711
yaron.gilboa@ashot.co.il
www.ashot.co.il

Ashutosh Power TransBelts Limited
707, HEMKOOT BUILDING,
OPP. CAPITAL COMMERCIAL CENTRE,
ASHRAM ROAD,
AHMEDABAD GUJARAT 380009
INDIA
Phone: +(91)-79-26580282
Fax: +(91)-79-26581238
aptbelts@gmail.com
www.aptbelts.com

ASI Technologies Inc.
405 CAREDEAN DRIVE
HORSHAM, PA 19044
Phone: (215) 674-8910
Fax: (215) 672-1816
rbanion@asidrives.com
www.asidrives.com

AST Bearings
115 MAIN ROAD
MONTVILLE, NJ 07045-9299
Phone: (800) 526-1250
Fax: (973) 335-6987
Inquiry@ASTBearings.com
www.ASTBearings.com

ATA Gears Ltd.
P.O. BOX 120
TAMPERE FIN-33101
FINLAND
Phone: +(358) 3287-0111
Fax: +(358) 3287-0249
postmaster@ata-gears.fi
www.ata-gears.fi

Atlanta Drive Systems Inc.
1775 ROUTE 34, UNIT D-10
WALL, NJ 07727
Phone: (732) 282-0480
Fax: (732) 282-0450
brad@atlantadrives.com
www.atlantadrives.com

Atlanta Gear Works, Inc
433 HIGHTOWER PARKWAY
DAWSONVILLE, GA 30534
Phone: (706) 216-5040
Fax: (706) 216-5052
jconway@atlantagear.com
www.atlantagear.com

Automation Direct SEE OUR AD
INSIDE FRONT COVER
3505 HUTCHINSON ROAD
CUMMING, GA 30040
Phone: (800) 633-0405
Fax: (770) 844-4212
sales@automationdirect.com
www.automationdirect.com

Autoparts Solutions Pvt Ltd
307, SAKET NAGAR
INDORE MADHYA PRADESH 452018
INDIA
Phone: 09303223845
Fax: 0731 4061351
sksagodbole@gmail.com
www.autopartssolutions.net

Avion Technologies Inc.
1203 LORIMAR DR.
MISSISSAUGA ON L5S 1M9
CANADA
Phone: (905) 670-1570
Fax: (905) 670-1568
sales@avion-tech.com
www.avion-tech.com

Axu s.r.l.
VIA POSTUMIA 12
MILAN ITALY 20153
ITALY
Phone: +39 0248202437
info@axu.it
www.axu.it/en

B&B Manufacturing, Inc.
1712 GENESIS DRIVE
LAPORTE, IN 46350
Phone: (888) 889-1896
Fax: (219) 324-2694
bob@bbman.com
www.bbman.com

B&R Machine and Gear Corp. SEE OUR AD
P9
4809 U.S. HWY. 45
SHARON, TN 38255
Phone: (731) 456-2636, OR (800)
238-0651
Fax: (731) 456-3073
inquiry@brgear.com
www.brgear.com

Bajrang Engineering Works
B-51 INDUSTRIAL AREA
G.T. KARNAL ROAD
DELHI NEW DELHI 110033
INDIA
Phone: +(91) 9810-024-875
Fax: +(91) 1127-459-563
bajrang51@rediffmail.com
www.bajranggears.com

Baker Bearing Company
13560 SE PHEASANT COURT
PORTLAND, OR 97222
Phone: (800) 875-6211
Fax: (503) 654-3701
john@bakerbearing.com
www.bakerbearing.com

Baldor Electric Company SEE OUR AD
P21
5711 R.S. BOREHAM, JR. ST.
P.O. BOX 2400
FORT SMITH, AR 72901
Phone: (479) 646-4711
Fax: (479) 648-5792
www.baldor.com

Barrel Service Company
105 S. PACIFIC ST.
SAN MARCOS, CA 92078
Phone: (800) 437-9079
Fax: (760) 744-5167
wbramble@sbcglobal.net
www.barrelservice.com



Bauer Gear Motor
EBERHARD BAUER STRASSE 36-60
ESSLINGEN 73734
GERMANY
Phone: +(49) 711 3518-0
Fax: +(49) 7113518-381
marketing@bauergears.com
www.bauergears.com

BC Gear Inc
3215 INDUSTRY DRIVE
N CHARLESTON, SC 29418
Phone: (843) 207-8700
Fax: (843) 207-1007
bcgear@aol.com
www.precisiongearmanufacturers.com

BC Manufacturing
705 SW 10TH ST.
BLUE SPRINGS, MO 64015
Phone: (816) 229-3300 x42
Fax: (816) 874-4984
markw@bc-mfg.com
bc-mfg.com

BDI - Bearing Distributors Inc.
8000 HUB PARKWAY
CLEVELAND, OH 44125
Phone: (216) 642-9100
Fax: (216) 642-9573
info@bdi-usa.com
www.bdi-usa.com

Bearing Service Company
630 ALPHA DRIVE
PITTSBURGH, PA 15238
Phone: (412) 963-7710
Fax: (412) 963-8005
GEARHUNTER@AOL.COM
www.bearing-service.com

Bearings and Industrial Supply Co., Inc.
431 IRMEN DRIVE
ADDISON, IL 60101
Phone: 630-628-1966
Fax: 630-628-0116
bearings4u@aol.com
bearingsnow.com

Bearings Limited
2100 PACIFIC STREET
HAUPPAUGE, NY 11788
Phone: (631) 273-8200
Fax: (631) 273-8257
sales@bearingslimited.com
www.bearingslimited.com

Beaver Aerospace and Defense Inc.
11850 MAYFIELD
LIVONIA, MI 48150
Phone: (734) 853-5155
Fax: (734) 853-5043
terry.roach@psi-corp.com
www.beaver-online.com

Befared
oferty@befared.com.pl
BIELSKO-BIALA EUROPE
POLAND
Phone: +48 (33) 8126031
Fax: +48 (33) 8164505
gadrianis2001@yahoo.fr
www.befared.com.pl

BEI Industrial Encoders
7230 HOLLISTER AVE
GOLETA, CA 93117
Phone: (800) 362-6337
Fax: (800) 960-2726
encoders@beied.com
www.beied.com

Beijing THC Limited
2 YANJINGXILI CHAOWAI CHAOYANG DISTRICT
BEIJING BEIJING 10025
CHINA
Phone: 86 (10) 8795-2546
Fax: 86 (10) 8795-2541
sales@beijingthc.com
www.beijingthc.com

Belcon Engineers P. Ltd.
A9 NEW SONAL INDL. ESTATE,
SAKI VIHAR ROAD,
MUMBAI MH 400072
INDIA
Phone: (022) 2857-5318/19
Fax: (022) 2857-5321
sales@belcon.co.in
www.belconengineers.com

Belden Inc.
2500 BRAGA DRIVE
BROAD VIEW, IL 60153
Phone: (708) 344-4600
Fax: (708) 344-0245
info@beldenuniversal.com
www.beldenuniversal.com

BellowsTech, LLC
1289 N. US HIGHWAY 1, STE. #1
ORMOND BEACH, FL 32174
Phone: (386) 615-7530
Fax: (386) 615-7973
bellows@bellowstech.com
www.bellowstech.com

Bently Pressurized Bearing Co.
1711 ORBIT WAY
MINDEN, NV 89423-4114
Phone: (775) 783-4600
Fax: (775) 783-4650
sales@bpb-co.com
www.bentlypressurizedbearing.com

Bervina
ERZSEBET KIRNÉ 41/B
BUDAPEST 1145
HUNGARY
Phone: +36 1 222-2079
Fax: +36 1 2524829
bervina@bervina.com
www.bervina.com

Best Parts Online
17752 COWAN ST
IRVINE, CA 92614
Phone: (949) 863-3126
sales@bestpartsonline.com
www.bestpartsonline.com/servlet/
StoreFront

Bevel Gears India Pvt. Ltd.
17 B, SADARAMANGALA INDUSTRIAL AREA,
WHITEFIELD ROAD,
BANGALORE 560048
INDIA
Phone: +(91) 8084-102-39 or 84-
103-12
Fax: +(91) 8084-101-85 or 52-823-
87
sulaimanjamal@yahoo.com
www.jamalgears.co.in

Beyta Gear Services SEE OUR AD
P88
ON230 COUNTY FARM ROAD
WINFIELD, IL 60190
Phone: (630) 209-1652
chuck@beytagear.com
www.beytagear.com

Bharat Gears Ltd.
HOECHST HOUSE, NARIMAN POINT
MUMBAI MAHARASHTRA 400021
INDIA
Phone: +(91) 2225-494-842
Fax: +(91) 2225-351-651
bphshah@bharatgears.com
www.bharatgears.com

Bibby Transmissions
CANNON WAY
DEWSBURY WEST YORKSHIRE WF13-1EH UK
UNITED KINGDOM
Phone: +(44) 1924460801
sales@bibbytransmissions.co.uk
www.bibbytransmissions.co.uk

Binsfeld Engineering Inc.
4571 W. MACFARLANE
MAPLE CREEK, MI 49664
Phone: (231) 334-4383
Fax: (231) 334-4903
sales@binsfeld.com
www.binsfeld.com

Bishop-Wisecarver Corp.
2104 MARTIN WAY
PITTSBURGH, PA 15205-5027
Phone: (925) 439-8272, OR (888)
580-8272
Fax: (925) 439-5931
sales@bwc.com
www.bwc.com

Bison Gear and Engineering Corp.
3850 OHIO AVE.
ST. CHARLES, IL 60174
Phone: (800) 282-4766
Fax: (630) 377-6777
info@bisongear.com
www.bisongear.com

Boca Bearing Company
1420 NEPTUNE DRIVE
SUITE A
BOYNTON BEACH, FL 33426
Phone: (800) 332-3256
Fax: (800) 409-9191
info@bocabearings.com
www.bocabearings.com

Bodine Electric Company
201 NORTHFIELD ROAD
NORTHFIELD, IL 60093
Phone: (773) 478-3515
Fax: (773) 478-3232
info@bodine-electric.com
www.bodine-electric.com

Boneng Transmission (Suzhou) Co., Ltd.
SUZHOU, P.R.CHINA
SUZHOU JIANGSU 215121
P.R.CHINA
Phone: +86-512-6618 9922
Fax: +86-512-6618-9966
norris@boneng.com
www.boneng.com

Boneng Transmission USA LLC
1670 ENTERPRISE PKWY.
TWINSBURG, OH 44087
Phone: (330) 425-1516
Fax: (330) 425-1519
america@boneng.com
www.boneng.com/English

Bonfiglioli Riduttori S.p.A.
VIA GIOVANNI XXIII, 7/A
40012 LIPPO DI CALDERARA BOLOGNA
ITALY
Phone: +(39) 051-6473-111
Fax: +(39) 051-6473-126
bonfiglioli@bonfiglioli.com
www.bonfiglioli.com

Bonfiglioli USA
3541 HARGRAVE DRIVE
HEBRON KY 41048
Phone: (859) 334-3333
Fax: (859) 334-8888
dan.bair@bonfiglioli.com
www.BonfiglioliUSA.com

Boston Gear
701 CARRIER DR.
CHARLOTTE, NC 28216
Phone: (704) 588-5610
Fax: (704) 588-7181
info@altramotion.com
www.bostongear.com

Bowman Hollis Mfg
2925 OLD STEELE CREEK ROAD
CHARLOTTE, NC 28208
Phone: (704) 374-1500
Fax: (704) 333-5520
sbroadwell@bowmanhollis.com
www.bowmanhollis.com

Bowmar LLC
8000 BLUFFTON ROAD
FORT WAYNE, IN 46809
Phone: (260) 747-3121
Fax: (260) 747-9601
jstephens@bowmarllc.com
www.bowmarllc.com

Brad Foote Gear Works, Inc
3250 S CENTRAL AVE
CICERO, IL 60804
Phone: (708) 298-1100
Sergio.Gamboa@BradFoote.com
www.bradfoote.com

BRECOflex CO., L.L.C.
222 INDUSTRIAL WAY WEST
P.O. BOX 829
EATONTOWN, NJ 07724
Phone: (732) 460-9500
Fax: (732) 542-6725
info@brecoflex.com
www.brecoflex.com

Brelie Gear Company, Inc
2715 S GLADSTONE PLACE
MILWAUKEE, WI 53207
Phone: (414) 481-5488
sjanke@breliegear.com
www.breliegear.com

Brevini Power Transmission - Canada
236 GALAXY BLVD.
TORONTO ONTARIO M9W 5R8
CANADA
Phone: (416) 674-2591
Fax: (416) 674-1478
amurphy@brevini.ca
www.brevini.com

Brevini USA
14141 W. BREVINI DRIVE
YORKTOWN, IN 47396
Phone: (765) 759-2300
Fax: (765) 759-2301
orderdesk@breviniusa.com
www.breviniusa.com/index.asp

Brevini Wind USA SEE OUR AD
P16,41,43,44
2400 N. PRIORITY WAY
YORKTOWN, IN 47396
Phone: (765) 759-2128
Fax: (765) 759-4728
dale.harder@brevini.com
www.breviniwind.com

Brewer Machine & Gear Co.
P.O. BOX 14726
ST. LOUIS, MO 63178
Phone: (314) 534-4021
info@brewertensioner.com
www.brewertensioner.com

Brighton Laboratories
11871 GRAND RIVER
BRIGHTON, MI 48116
Phone: (810) 225-9520
Fax: (810) 225-9528
support@brightonlabs.com
www.brightonlabs.com

Broadway Gear
2217 EXECUTIVE DRIVE
GARLAND, TX 75041
Phone: (972) 351-8737
info@broadwaygear.com
www.broadwaygear.com

Brother Gearmotors SEE OUR AD
P23
200 CROSSING BLVD.
BRIDGEWATER, NJ 08807
Phone: (866) 523-6283
gearmotors@brother.com
www.brother-usa.com

Buehler Motor, Inc.
860 AVIATION PARKWAY
SUITE 300
MORRISVILLE, NC 27560
Phone: (919) 380-3333
Fax: (919) 380-3256
ute.hickman@buehlermotor.com
www.buehlermotor.com

Buffalo Gear, Inc.
3635 LOCKPORT ROAD
SANBORN, NY 14132
Phone: (888) BUFF-GEAR
Fax: (716) 731-2553
info@buffalogear.com
www.buffalogear.com

Butler Gear
12819 WEST SILVER SPRING RD.
BUTLER, WI 53007
Phone: (262) 781-3270
Fax: (262) 781-1896
gears@butlertgear.com
www.butlertgear.com

C&U Americas, LLC
45901 FIVE MILE ROAD
PLYMOUTH, MI 48170
Phone: (734) 656-0260
Fax: (734) 656-0261
contact@cubearing.com
www.cubearing.com

SEE OUR AD
P32

C-B Gear & Machine
P.O. BOX 111278
HOUSTON TEXAS 77293
Phone: (281) 449-0777
Fax: (281) 590-9127
tom@cbgear.com
www.cbgear.com

Cabat Inc.
5501 21ST STREET
RACINE, WI 53401-1616
Phone: (262) 898-5937
Fax: (262) 554-7503
Bgreuel@cabatinc.com
www.cabatinc.com

SEE OUR AD
P2

Calicut Engineering Works Limited
"DUMRAON HOUSE", 2ND FLOOR, SUITE# 6,
26A, CAMAC STREET,
P. O. BOX# 9119,
CALCUTTA / KOLKATA WEST BENGAL 700 016
INDIA
Phone: +91 33 2287 1979 / 5693
Fax: +91 33 2287 6072
calicut@hotmail.com
www.calicutengineering.com

Capstan Atlantic
10 CUSHING DRIVE
WRENTHAM, MA 02093
Phone: (508) 384-3100
Fax: (508) 384-3196
sales@capstanatlantic.com
www.capstanatlantic.com

Carlisle Power Transmission
2601 WEST BATTLEFIELD ROAD
SPRINGFIELD, MO 65807
Phone: (866) 773-2926
info@carlislebelts.com
www.carlislebelts.com

Carlyle Johnson Machine Co. LLC, The
P.O. BOX 9546
BOLTON, CT 06043-9546
Phone: (860) 643-1531
Fax: (860) 646-2645
tomt@cjmco.com
www.cjmco.com

Carnes-Miller Gear Co., Inc.
PO BOX 268
LOCUST, NC 28097
Phone: (800) 273-6814
Fax: (740) 888-4554
info@cmgear.com
www.cmgear.com

Cattini & Figlio s.r.l.
VIA DELL'ECOLOGIA 1
CASARILE 20080
ITALY
Phone: +(39) 0290-0531
Fax: +(39) 0290-053-218
info@cattini.com
www.cattini.com

CCVI Bearing
27561 HILLVIEW CT
MUNDELEIN, IL 60060
Phone: (847) 540-8196
Fax: (847) 540-9130
tryan@ccvibearing.com
www.ccvibearing.com

CENTA Corp.
2570 BEVERLY DRIVE #128
AURORA, IL 60502
Phone: (630) 236-3500 ext.117
Fax: (630) 236-3565
PTE@centacorp.com
www.centa.info

Central Gear & Machine
10 GLENLAKE PARKWAY #130
ATLANTA, GA 30328
Phone: (678) 895-5383
Fax: (678) 222-3401
centralgear4@aol.com
www.cgmtatlanta.com/

Centritec Seals, LLC
291 BOSTON TURNPIKE
BOLTON, CT 06043
Phone: (860) 643-1531
Fax: (860) 646-2645
www.centritecseals.com

Certified Reducer Rebuilders Inc
32079 MILTON
MADISON HEIGHTS, MI 48071
Phone: (248) 585-0883
Fax: (248) 589-1166
mrugercrr@aol.com
www.certifiedreducer.net

Cestari Industrial e Comercial S.A.
ROD. MONTE ALTO - VISTA ALEGRE, KM3
MONTE ALTO S/O PAULO 15910-000
BRAZIL
Phone: +55 (16) 3244 1022
Fax: +55 (16) 3244 1025
cestari@cestari.com.br
www.cestari.com.br

CHA Industries, Inc.
1720 WALLACE AVE., UNIT B
ST. CHARLES, IL 60174
Phone: (877) 432-7738
Fax: (866) 806-7738
sales@chagear.com
www.chagear.com

**Challenge Power Transmission (Aust)
Pty Ltd**
B11 SCORESBY INDUSTRY PARK
JANINE STREET
SCORESBY VICTORIA 3179
AUSTRALIA
Phone: +61 (03) - 9763 6701
Fax: +61 (03) - 9764 5639
graham@challengept.com
www.challengept.com

Challenge Power Transmission PLC
MERRYHILLS ENTERPRISE PARK
PARK LANE
WOLVERHAMPTON WV10 9TJ
UNITED KINGDOM
Phone: 0044 1902 866116
Fax: 0044 1902 866117
uksales@challengept.com
www.challengept.com

Chengdu Talent Industrial Co., Ltd.
NO.8, JULIDI BEI ROAD,
CHENGDU, SICHUAN
CHINA
CHENGDU SICHUAN 610031
CHINA
Phone: 0086-28-83836380
Fax: 0086-28-87609330
tt@ttindustrial.com
www.ttindustrial.com

Chenta USA
26241 ENTERPRISE CT.
LAKE FOREST, CA 92630
Phone: (949) 579-2789
Fax: (949) 206-0868
albert@chenta.com
www.chenta.com

Chongqing Rainbow M&E Co., Ltd
NO 18-22, YANGHE ERCUN JIANGBEI DISTRICT
CHONGQING CITY
CHINA
CHONGQING CHONGQING 400020
CHINA
Phone: 8623-67705315-806
Fax: 8623-67705763
ie@cqrainbow.com
www.cqrainbow.com

CIMA S.p.A.
VIA CAIROLI, 8
VILLANOVA DI CASTENASO 40050
ITALY
Phone: +(39) 0516-053-088
Fax: +(39) 0516-053-292
salesdept@cimaingranaggi.it
www.cimaingranaggi.it

Circle Gear & Machine Co.
1501 S. 55TH COURT
CICERO, IL 60804
Phone: (708) 652-1000
Fax: (708) 652-1100
cirtgear@circlegear.com
www.circlegear.com

SEE OUR AD
P25

Clark Gear Works, Inc.
1218 SARATOGA DRIVE
CAROL STREAM, IL 60188
Phone: (630) 561-2320
Fax: (630) 293-3444
dppapro@msn.com
www.clarkgearworks.com

Clarke Engineering Inc. (Clarke Gear Co.)
8058 LANKERSHIM BLVD.
NORTH HOLLYWOOD, CA 91605
Phone: (818) 768-0690
Fax: (818) 767-5577
clarkegear@earthlink.net
clarkegear.com

Cleveland Gear Co.
3249 E. 80TH STREET
CLEVELAND, OH 44104
Phone: (800) 423-3169
Fax: (216) 641-0616
sales@clevelandgear.com
www.clevelandgear.com

Climax Metal Products Company
8141 TYLER BLVD.
MENTOR, OH 44060
Phone: (800) 542-6552
Fax: (800) 860-5553
tina@climaxmetal.com
climaxmetal.com

Cloyes Gear & Products Inc.
3939 W. HAMLIN RD.
ROCHESTER HILLS, MI 48309
Phone: (248) 340-9704
mmadley@cloyes.com
www.cloyes.com

CMS Vibration Solutions Ltd
4 EAGLE PARK
EAGLE PARK DRIVE
WARRINGTON CHESHIRE WA2 8JA
UNITED KINGDOM
Phone: 0044 (0)1925 582 899
Fax: 0044 (0)1925 582 898
info@cmsantivibration.co.uk
www.cmsantivibration.co.uk

Cogmatic, Inc.
6601 N. 40TH ST
MILWAUKEE, WI 53209
Phone: (414) 353-7500
Fax: (414) 353-7507
mike@cogmatic.com
www.cogmatic.com

Collars and Coupling
PO BOX 1168
WEST SPRINGFIELD, MA 01090
Phone: (800) 593-2323
info@collarsandcouplings.com
www.collarsandcouplings.com

Columbia Gear Corp.
530 COUNTY ROAD 50
AVON, MN 56310
Phone: (800) 323-9838
Fax: (320) 356-2131
info@columbiagear.com
www.columbiagear.com

ComInTec Srl
VIA DELL'ARTIGIANO, 9
40055, VILLANOVA (BO)
ITALY
Phone: +39 051 780216
Fax: +39 051 782256
export@comintec.it
www.comintec.it

Commercial Gear & Sprocket Co. Inc.
618 WASHINGTON STREET
E. WALPOLE, MA 02032
Phone: (508) 668-1073
Fax: (508) 668-6625
info@commercialgear.com
www.commercialgear.com

Comtec Mfg., Inc.
P.O. BOX 940
1012 DELAUM ROAD
ST. MARYS, PA 15857
Phone: (814) 834-9300
Fax: (814) 834-2303
sales@comtecmfg.com
www.comtecmfg.com

Cone Drive
240 EAST 12TH STREET
TRAVERSE CITY, MI 49685-0272
Phone: (888) 994-2663
Fax: (888) 907-2663
orders@conedrive.com
www.conedrive.com

SEE OUR AD
P39

Conroll Corporation
3302 KITTY HAWK ROAD
WILMINGTON, NC 28405
Phone: (910) 202-4290
Fax: (910) 202-4280
chuck@conroll.com
www.conroll.com

ContiTech North America
136 SUMMIT AVENUE
MONTVALE NEW JERSEY 07645
Phone: (201) 930-0600
info@contitech-usa.com
www.contitech.com

SEE OUR AD
P35

Control Switches International Inc (csii)
2425 MIRA MAR AVE
LONG BEACH, CA 90815
Phone: (562) 498-7331
Fax: (562) 498-2402
sales_info@controlswitches.com
www.controlswitches.com

Core Supply LLC
1954 N. FAYETTEVILLE ST
ASHEBORO, NC 27203
Phone: (336) 672-3000
Fax: (336) 672-2900
admin@coresupplyllc.com
www.coresupplyllc.com

Coremo Ocmea S.r.l.
VIA GALILEI 12
ASSAGO (MI) I-20090
ITALY
Phone: +(39) 0248-806-97
Fax: +(39) 0248-819-40
coremo@ocmea.it
www.coremo.ocmea.it

Cori Engineers Private Limited
79, VALMIKI STREET
THIRUVANMIYUR
CHENNAI - 600041 TAMIL NADU
INDIA
Phone: +(91) 44-24420608
Fax: +(91) 44-24405152
igp@vsnl.com
www.igp-group.com

Cortec Corporation
4119 WHITE BEAR PARKWAY
ST. PAUL MINNESOTA 55110
Phone: (651) 429-1100
Fax: (651) 429-1122
info@cortecvci.com
www.cortecvci.com

Cotta Transmission Co. LLC
1301 PRINCE HALL DRIVE
BELOIT, WI 53511
Phone: (608) 368-5600
Fax: (608) 368-5605
sales@cotta.com
cotta.com

Craft Bearing Company, Inc.
5000 CHESTNUT AVE.
NEWPORT NEWS, VA 23605
Phone: (757) 247-6000
Fax: (757) 247-6300
info@craftbearing.com
www.craftbearing.com

Cross + Morse
SHADY LANE
GREAT BARR
BIRMINGHAM WEST MIDLANDS B44 9EU
UNITED KINGDOM
Phone: 0121 360 0155
Fax: 0121 325 1079
sales@crossmorse.com
www.crossmorse.com/index2.html?main.asp&0

Cryotron Magnadrives
A-104, SAI SNEHA INDUSTRIAL ESTATE,
PHATAK ROAD,
BHAYANDER EAST, DISTT THANE
MUMBAI MAHARASHTRA 401105
INDIA
Phone: 91 22 28190433
Fax: 91 22 28191473
cryotron@satyam.net.in
www.cmdindia.com

CUI Inc
20050 SW 112TH AVENUE
TUALATIN, OR 97062
Phone: (800) 275-4899
Fax: (503) 612-2383
sales@cui.com
www.cui.com

Currie Enterprises
382 N. SMITH ST.
CORONA, CA 92880
Phone: (714) 528-6957
travis@currieenterprises.com
www.currieindustrial.com

Curtis Machine Co. Inc.
P.O. BOX 700
2500 EAST TRAIL STREET
DODGE CITY, KS 67801
Phone: (620) 227-7164
Fax: (620) 227-2971
curtis@curtismachine.com
curtismachine.com

Custom Gear & Machine Inc.
5466 EAST ROCKTON ROAD
ROSCOE, IL 61073
Phone: (815) 389-6065
Fax: (815) 389-4548
mras41666@aol.com
www.cgearinc.com

Custom Machine & Tool Co. Inc.
22 STATION STREET
E. WEYMOUTH, MA 02189
Phone: (781) 331-7770
Fax: (781) 335-6784
info@cmtco.com
www.cmtco.com

Custom Motors Inc.
1725 LAKE DRIVE WEST
CHANHASSEN, MN 55317
Phone: (952) 361-9405
Fax: (952) 361-9410
lisa.anderson@custom-motorsinc.com
www.custom-motorsinc.com

Custom Sensors & Technologies
14501 PRINCETON AVENUE
MOORPARK, CA 93021
Phone: (805) 552-3599
Fax: (805) 552-3577
info@cst.schneider-electric.com
www.ctsensors.com/

Cutes Corporation
NO. 2-22, NAN YUAN RD.,
CHUNG LI CITY TAOYUAN 320
TAIWAN
Phone: 886-3-4612333
Fax: 886-3-4526227
sales@cutes.com.tw
www.cutes.com.tw

Cyclo-Index
1129 W. FAIRVIEW AVE.
CARTHAGE, MO 64836
Phone: (417) 358-6136
Fax: (417) 358-8629
info@cycloindex.com
www.cycloindex.com

D G Steel & Son Engineering Ltd.
BARNBROOK GEAR WORKS
BROOK STREET
BURY LANCASHIRE BL9 6AF
UNITED KINGDOM
Phone: +(44) 0161 7644862
jennifer-steel@hotmail.com
www.dgsteel.com

D&D Intl. Corp.
C/O FINACIAL INTERLINK, 13216 SW 45TH
LANE
MIAMI, FL 33175
Phone: (305) 793-2030
oec.ltd@superonline.com
www.powerdrive-belt.com

Daemar Inc.
861 CRANBERRY COURT
OAKVILLE ONTARIO L5G 3V5
CANADA
Phone: (905) 847-6500
Fax: (905) 847-6943
cpirie@daemarinc.com
www.daemar.com

Daido Corporation of America
1031 FRED WHITE BLVD
P.O. BOX 7659
PORTLAND, TN 37148
Phone: (615) 323-4020
Fax: (615) 3234015
carrierl@daidocorp.com
www.daidocorp.com

Dalton Bearing Service, Inc.
P.O. BOX 1363
DALTON, GA 30722
Phone: (706) 629-1336
Fax: (706) 629-2252
sales@daltonbearing.com
www.daltonbearing.com

Danaher Motion and Thomson
45 HAZELWOOD DR.
AMHERST, NY 14228
Phone: 1-540-633-3400
Fax: 1-540-639-4162
contactus@danahermotion.com
www.danahermotion.com

Darbar Belting
1, PRASTHAN-1 NEAR SAYONA CITY ROAD
GHATLODIA
AHMEDABAD GUJARAT 380061
INDIA
Phone: +(91) 98-2502-3086
darbarbelting@yahoo.co.in
www.darbarbelting.co.in/

Datasyst Engineering & Testing Services, Inc.
514 W33511 HIGHWAY 18
DELAFIELD, WI 53018
Phone: (800) 698-4008
sales@datasysttest.com
www.datasysttest.com

Daubert Cromwell LLC
12701 S. RIDGEWAY AVE,
ALSIP, IL 60803
Phone: (708) 293-7750
Fax: (708) 293-7765
info@daubertcromwell.com
www.daubertcromwell.com

Davall Gears Ltd.
TRAVELLERS LANE, WELHAM GREEN
HATFIELD HERTFORDSHIRE AL9 7JB
U.K.
Phone: +(44) 170 728 3100
Fax: +(44) 170 728 3111
info@davall.co.uk
www.davall.com

David Brown
PARK ROAD
LOCKWOOD
HUDDERSFIELD YORKSHIRE HD4 5DD
UNITED KINGDOM
Phone: +44 (0) 1484 465 500
Fax: +44 (0) 1484 465 586
sales@davidbrown.textron.com
www.davidbrown.com

Dee Bee Enterprise
C-1/4 URMI APARTMENTS, FATEHGUNJ
VADODARA GUJARAT 390002
INDIA
Phone: 912652787845
Fax: 912652794341
dbe@deebie-enterprise.com
www.deebie-enterprise.com

Del-Tron Precision Inc.
5 TROWBRIDGE DRIVE
BETHEL, CT 06801
Phone: (203) 778-2727
Fax: (203) 778-2721
deltron@deltron.com
www.deltron.com

Dellner Brakes AB
172 QUEENS RIVER DRIVE
WEST KINGSTON, RI 02892
Phone: (401) 515-4657
Fax: (401) 515-4542
glenn.scott@dellner-brakes.com
www.dellner-brakes.com

Delroyd Worm Gear
2221 NIAGARA FALLS BLVD.
NIAGARA FALLS, NY 14302
Phone: (716) 731-5180
Fax: (716) 731-9329
jay.dubell@delroyd.com
www.delroyd.com

Delta Gear Company
345 SUN VALLEY CIRCLE
FENTON, MO 63026
Phone: (636) 343-0311
Fax: (800) 548-1965
PMuckermanjr@deltagearcompany.com
www.deltagearcompany.com

Delta Gear Corp.
36251 SCHOOLCRAFT
LIVONIA, MI 48150
Phone: (734) 525-8000
Fax: (734) 525-8400
tony.w@delta-gear.com
www.delta-gear.com

Delta Inspection
36251 SCHOOLCRAFT
LIVONIA, MI 48150
Phone: 734-525-8000
Fax: 734-525-8400
tonyw@delreccorp.com
www.deltaresearch.com

Delta Research Corp.
36251 SCHOOLCRAFT
LIVONIA, MI 48150
Phone: (734) 525-8000
Fax: (734) 525-8400
tony.w@delta-gear.com
www.deltaresearch.com

DePe Gear Company Ltd
UNIT 1, GROVE ROAD IND ESTATE
GROVE ROAD
FENTON
STOKE ON TRENT STAFFORDSHIRE ST4 4LG
UNITED KINGDOM
Phone: 00(44) 1782594114
Fax: 00(44) 1782 594115
sales@depe.co.uk
www.depe.co.uk

Desch Canada Ltd.
240 SHEARSON CRESCENT
CAMBRIDGE ONTARIO N1T 1J6
CANADA
Phone: (519) 621-4560
Fax: (519) 623-1169
desch@desch.on.ca
www.desch.de

Designatronics, Inc.
2101 JERICHO TURNPIKE
NEW HYDE PARK, NY 11040
Phone: (516) 328-3300
Fax: (516) 326-8827
info@designatronics.com
www.designatronics.com

SEE OUR AD
BACK COVER
P34, 35,
40, 42, 45

Deutsche Messe AG
MESSEGELENDE
30521 HANNOVER
GERMANY
Phone: +(49) 511-89-0
Fax: +(49) 511-89-32626
www.messe.de

SEE OUR AD
P77

Diamond Chain Company
402 KENTUCKY AVENUE
INDIANAPOLIS, IN 46225
Phone: (800) 872-4246
Fax: (317) 613-2243
sales@diamondchain.com
www.diamondchain.com

DieQua Corp.
180 COVINGTON DRIVE
BLOOMINGDALE, IL 60108
Phone: (630) 980-1133
Fax: (630) 980-1232
info@diequa.com
www.diequa.com

SEE OUR AD
P17

Dimatic Die & Tool Co.
P.O. BOX 12037
OMAHA, NE 68112-0037
Phone: (402) 571-7300
www.dimatic.com

Dings Company
4740 W ELECTRIC AVENUE
MILWAUKEE, WI 53219
Phone: (414) 672-7830
Fax: (414) 672-5354
jboswell@dingsco.com
www.dingsbrakes.com

Discovery Technology International, Inc.
6968 PROFESSIONAL PARKWAY EAST
SARASOTA, FL 34240
Phone: (941) 907-4444
Fax: (941) 907-4512
info@discovtech.com
www.discovtech.com

Dn Sales Australia
PO BOX 630
CARINGBAH
SYDNEY NSW 1495
AUSTRALIA
Phone: 61 2 95402297
Fax: 61 2 9531 2897
dnsales@bigpond.com
www.dnsales.com.au

Drive Components LLC
6519 EASTLAND RD
STE 106
BROOKPARK, OH 44142
Phone: (440) 234-6200
Fax: (440) 234-1200
sales@drivecomponentsllc.com
www.drivecomponentsllc.com

Drive Lines Technologies Ltd
45 MURDOCK ROAD
BEDFORD BEDFORDSHIRE MK41 7PQ
UNITED KINGDOM
Phone: +(44) 01234 360689
Fax: +(44) 01234 345673
Sales@Drivelines.co.uk
www.drivelines.co.uk

Drive Systems Technology Inc.
24 MARLBOROUGH LANE
GLEN MILLS, PA 19342-1519
Phone: (610) 358-0785
Fax: (610) 358-2776
geardoc@comcast.net
www.gear-doc.com

Duff Norton Australia
FACTORY 2, 17-19 ORANGE ST.
WILLIAMSTOWN VICTORIA 3016
AUSTRALIA
Phone: +(61) 3-93998006
contact@duffnorton.com.au
www.duffnorton.com.au/

Dunkermotoren USA Inc.
2511 TECHNOLOGY DRIVE
SUITE 105
ELGIN, IL 60124
Phone: (224) 293-1300
Fax: (224) 293-1301
john.morehead@dunkermotoren.com
www.dunkermotor.com

Dura-Belt
2909 SCIOTO DARBY EXEC. CT.
HILLIARD, OH 43026
Phone: (800) 770-2358
Fax: (614) 777-9448
jim@durabelt.com
www.durabelt.com

Durabond Slides
5627 AIRLINE ROAD
FRUITPORT, MI 49415
Phone: (231) 865-1800
Fax: (231) 865-1802
kurtw@durabondslide.com
www.durabondslide.com

Dymco, Co
2-10-27, KITAWAIWAI, NISHI-KU,
YOKOHAMA, 220-0004, JAPAN
JAPAN
Phone: 81-45-322-2822
Fax: 81-45-322-2824
k.sawa@dymco.co.jp
www.dymco.co.jp

Dynamic Structures and Materials, LLC
205 WILLIAMSON SQ
FRANKLIN, TN 37064
Phone: (615) 595-6665
salesinfo@dynamic-structures.com
www.dynamic-structures.com

Dynex/Rivett Inc.
770 CAPITOL DR.
PEWAUKEE, WI 53072
Phone: (262) 691-2222
Fax: (262) 691-0312
sales@dynexhydraulics.com
www.dynexhydraulics.com

EDT Corp
1006 J, NE 146TH STREET
VANCOUVER WA 98685
Phone: (360) 574-7294
Fax: (360) 574-3834
scottd@edtcorp.com
www.edtcorp.com

EIC Industry Group
53 GREEN POND ROAD SUITE 3
ROCKAWAY, NJ 07866
Phone: (973) 983-1988
Fax: (973) 983-2688
support@eicind.com
www.eicind.com

Electro Static Technology
31 WINTERBROOK RD.
MECHANIC FALLS ME 04256
Phone: (207) 998-5140
sales@est-aegis.com
www.est-aegis.com/index.php

Electro Steel Engineering Company
38 NAGDEVI CROSS LANE
GROUND FLOOR
MUMBAI MAHARASHTRA 400003
INDIA
Phone: 0091-22-3435361
Fax: 0091-22-2341211
tanaygupta@hotmail.com
www.indiamart.com/tyginc

Electromatic Engineers Pvt. Ltd
8 - B, SAHELI MARG,
UDAIPUR, RAJASTHAN, 313001
INDIA
Phone: +91 294 2526933, 2560675
Fax: +91 294 2526525
electromatickol@hotmail.com
www.clutchesbrakes.com

Electronic Machine Parts
400 OSER AVE
HAUPPAUGE, NY 11788
Phone: (631) 434-3700
sales@empregister.com
www.empregister.com

Elektrim Motors
2015 S MITCHELL BLVD
SCHAUMBURG, IL 60193
Phone: (847) 524-1074
Fax: (847) 524-9996
support@elektrimmotors.com
www.elektrimmotors.com

Elliot Mfg USA
11 BECKWITH AVENUE
BINGHAMPTON, NY 13901
Phone: (607) 772-0404
sales@elliottmfg.com
www.elliottmfg.com

EM Gear / Dae Seong Gear
10730 PACIFIC STREET SUITE 226
OMAHA NEBRASKA 68114
Phone: (402) 933-3314
Fax: (402) 933-3474
d_seong@hotmail.com
www.em-gear.com

Emco Dynatorq Pvt. Ltd. (Formerly Emco Lenze Pvt.)
1ST FLOOR, SITA MAULI, WING
ABOVE BANK OF MAHARASHTRA, M D ROAD,
PANCH PAKHADI
THANE (W) MAHARASHTRA 400602
INDIA
Phone: +912225452244
Fax: +912225452233
info@emco-dynatorq.in
www.emco-dynatorq.in

Emerson Industrial Automation - Drives & Motor
7078 SHADY OAK ROAD
EDEN PRAIRIE, MN 55344
Fax: 952-995-8130
meg.krekeler@emerson.com
www.emersonindustrial.com

Emerson Power Transmission
POWER TRANSMISSION SOLUTIONS
7120 BUFFINGTON ROAD
FLORENCE KY 41042
Phone: (800) 626-2120
Fax: (800) 262-3292
Jackie.Catalano@emerson.com
www.emerson-ept.com

Equipment Concepts
400 LINDEN AVE
DAYTON, OH 45403
Phone: 937 258 1755
Fax: 937 258 1755
franer@frognet.net
www.equipment-concepts.com

Essential Power Transmission Pvt. Ltd.
6, HYTEX IND. ESTATE, S.V. RD., DAHISAR (E)
MUMBAI MAHARASHTRA 400068
INDIA
Phone: +91 2228488742
Fax: +91 2228488147
esenpro@bom3.vsnl.net.in
www.esenpro.com

Excel Gear, Inc.
11865 MAIN STREET
ROSCOE, IL 61073
Phone: 815-623-3414
Fax: 815-623-3314
chinn@excelgear.com
www.excelgear.com

SEE OUR AD
P22

Exlar Corporation
1470 LAKE DRIVE WEST
CHANHASSEN, MN 55317
Phone: (952) 368-3434
Fax: (952) 368-4877
info@exlar.com
www.exlar.com

F.K. Bearings
865 W. QUEEN ST.
SOUTHINGTON, CT 06489
Phone: (800) 662-4003
Fax: (860) 276-0463
sales@fkrodends.com
www.fkrodends.com

Fagor Automation
2250 ESTES AVE
ELK GROVE VILLAGE, IL 60007
Phone: (847) 9811500
Fax: (847) 809 6318
egalzin@fagor-automation.com
www.fagor-automation.com

Fairchild Industrial Products Co.
3920 WEST POINT BLVD.
WINSTON-SALEM, NC 27103
Phone: (336) 659-3400
Fax: (336) 659-9323
sales@fairchildproducts.com
www.spectransmission.com

Festo Corporation
395 MORELAND ROAD
HAUPPAUGE, NY 11788
Phone: (800) 99-FESTO
Fax: (800) 96-FESTO
customer.service@us.festo.com
www.festo.com/usa

Fey Laminar Rings - North America
575 ROUTE 73 NORTH
BLDG B3
WEST BERLIN, NJ 08091
Phone: (856) 336-1011
Fax: (856) 768-8708
info@fey-na.com
www.fey-na.com

Fife Corporation
P.O. BOX 26508
OKLAHOMA CITY OK 73126
Phone: (405) 755-1600
www.fife.com

Firma Martin N.V.
MANDELSTRAAT 74
IZEGEM B-8870
BELGIUM
Phone: +32 51 331940
Fax: +32 51 331946
sales@mtimartin.be
www.mtimartin.be

First Gear Engineering & Technology
7606 FREEDOM WAY
FORT WAYNE, IN 46818
Phone: (260) 490-3238
Fax: (260) 490-4093
greg@first-gear.com
www.first-gear.com

SEE OUR AD
P11

FK Bearing Corp.
NO71-87, LIANTANG ROAD, NORTH INDUS-
TRIAL ZONE, JIMEI
XIAMEN FUJIAN 361021
CHINA
Phone: +86-592-6689006
Fax: +86-592-6689007
ljz@fk-bearing.com
www.fk-bearing.com

Flexocon Engineers Private Limited
ABAKASH APARTMENT, FLAT 1C,
14 MIG HOUSING ESTATE,
SODEPUR
KOLKATA WEST BENGAL 700110
INDIA
Phone: +9133-25230864
Fax: +9133-25230866
flexocon@gmail.com
www.flexoconindia.com

FMC Engineering
P.O. BOX 31115
HOUSTON, TX 77231
Phone: (713) 988-7700
sales@fmcengineering.com
www.fmcengineering.com

Force Control Industries
3660 DIXIE HIGHWAY
FAIRFIELD, OH 45014
Phone: (513) 868-0900
Fax: (513) 868-2105
tstoner@forcecontrol.com
www.forcecontrol.com

Forest City Gear Co.
11715 MAIN STREET
ROSCOE, IL 61073
Phone: (815) 623-2168
Fax: (815) 623-6620
rmikel@fcgear.com
www.fcgear.com

SEE OUR AD
P13

Formsprag Clutch
23601 HOOVER RD.
WARREN, MI 48089
Phone: (586) 758-5000
Fax: (586) 758-5204
formsprag.clutch@formsprag.com
www.formsprag.com

Framo Morat Inc.
9440 SAN MATEO BLVD NE
SUITE L
ALBUQUERQUE, NM 87113
Phone: (505) 359-2949
Fax: (505) 881-2070
sales@framo-morat.com
www.framo-morat.com

FSI Technologies Inc.
668 WESTERN AVE.
LOMBARD, IL 60148
Phone: (630) 932-9380
Fax: (630) 932-0016
info@fsinet.com
www.fsinet.com

Fusion Babbiting Co, Inc
4540 W. BURNHAM ST.
MILWAUKEE, WI 53219
Phone: (414) 645-5800
mmckindley@sbcglobal.net
www.fusionbabbiting.com

Future Technologies, Inc.
2490 MIDLAND ROAD
BAY CITY, MI 48706-9469
Phone: (989) 686-6200
Fax: (989) 686-3070
davidl@futuretechnologies.com
www.fttech.com

Gajra Gears Pvt. Ltd.
STATION ROAD
DEWAS MP 455001
INDIA
Phone: +91-7272-421000
Fax: +91-7272-421001
gautam@gajra.com
www.gajra.com

Galil Motion Control
270 TECHNOLOGY WAY
ROCKLIN, CA 95765
Phone: (800) 377-6329
www.galilmc.com

GAM Gear
901 E. BUSINESS CENTER DRIVE
MOUNT PROSPECT, IL 60056
Phone: (847) 649-2500
Fax: (847) 649-2501
marketing@gamweb.com
www.gamweb.com

Gates Corporation
1551 WEWATTA ST.
DENVER, CO 80202
Phone: (303) 744-5473
Fax: (303) 744-4910
gates@powertransmission.com
www.gates.com

Gayatri Gear Industries
73,74 ASHAPURA ESTATE, RAMOL
CHOKDI, PH-IV, GIDC, VATVA
AHMEDABAD GUJARAT 382445
INDIA
Phone: 0091 79 25840180
Fax: 00917925840180
info@gayatrigeear.com
www.gayatrigeear.com

Gear Design & Service Pty. Ltd.
355 SETTLEMENT ROAD
THOAMSTOWN VICTORIA 3074
AUSTRALIA
Phone: +61 3 9465 6355
Fax: +61 3 9465 6744
sales@geardesign.com.au
www.geardesign.com.au

Gear Manufacturing Inc.
3721 E. MIRALOMA AVE.
ANAHEIM, CA 92806
Phone: (714) 792-2895
Fax: (714) 792-2870
info@gearmfg.com
www.gearmfg.com

Gear Master Inc.
7481 RESEARCH DR
ALMONT, MI 48003
Phone: (810) 798-9254
Fax: (810) 798-0224
troach@gearmaster.com
www.gearmaster.com

GearVisions, Inc.
38310 WILLOUGHBY PARKWAY
WILLOUGHBY, OH 44094
Phone: (440) 951-4327
Fax: (440) 951-6230
marketing@gearvisions.com
www.gearvisions.com

Genemax Industrial Inc.
33, SHIN-YI ROAD,
AN-PING INDUSTRIAL DISTRICT,
TAINAN 702, TAIWAN
TAINAN 702
TAIWAN
Phone: +(886) 62637999
Fax: +(886) 62637950
info@gmx.com.tw
www.gmx.com.tw

George Lane & Sons Ltd
BANNERLEY ROAD
GARRETS GREEN
BIRMINGHAM WEST MIDS B33 0SL
UNITED KINGDOM
Phone: 44 (0) 121-784-5525
Fax: 44 (0) 121-783-6988
info@georgelane.co.uk
www.georgelane.co.uk

Ghatge Patil Industries
UCHGOAN
KOLHAPUR
MAHARASTRA
KOLHAPUR MAHARASTRA 416007
INDIA
Phone: 9823192225
Fax: NA
corporate@gpind.com
www.gpind.com

Gil Equipamentos Industriais Ltda.
RUA GUIANA FRANCESA, 724 / 740 - VILA
ELISA
RIBEIRÃO PRETO SÃO PAULO 14075-220
BRAZIL
Phone: 55 16 3626-2800
Fax: 55 16 3626-2098
tulio-marcus@uol.com.br
www.gil.com.br

GKN Driveline
HAUPTSTRASSE 130
LOHMAR GERMANY 53797
GERMANY
Phone: +49 2246 100 2239
davede.trinca@gkndriveline.com
www.gkndriveline.com

Gleason K2 Plastics
8210 BUFFALO ROAD
BERGEN, NJ 14416
Phone: (585) 494-2470
Fax: (585) 494-2474
www.k2plasticsinc.com

GMB Associates
5 ARIANE, LICHFIELD ROAD INDUSTRIAL
ESTATE
TAMWORTH, STAFFORDSHIRE B79 7XF
TAMWORTH
UNITED KINGDOM
Phone: +(44) 182757561
Fax: +(44) 182761832
sales@gmbassociates.co.uk
www.gmbassociates.co.uk

GMN Bearing Usa, Ltd.
12633 SHILOH CHURCH ROAD
HOUSTON, TX 77066
Phone: (800) 323-5725
Fax: (888) 858-8678
sales@gmnbt.com
www.gmnbt.com

GMN Paul Miller Industrie GmbH & Co. KG
AUBERE BAYREUTHER STRABE
NERNBERG BAYERN 90411
GERMANY
Phone: +49 (0)911 5691-0
Fax: +49 (0)911 5691-587
info@gmn.de
www.gmn.de

Goodwill Engineering
C-1, RING ROAD, NARAINA
DELHI 110028
INDIA
Phone: +(91) 9811911144
Fax: +(91) 11 25778692
gewindia@rediffmail.com
www.gewindia.com

GP:50 Corporation
2770 LONG ROAD
GRAND ISLAND, NY 14072
Phone: (800) 309-6150
Fax: (716) 773-5019
inquiries@embassyglobalpr.com
www.GP50.com

Great Northern Products Inc.
PO BOX 750
EXETER, NH 03833
Phone: (888) 887-4549
Fax: (888) 811-6858
nknox@gnpinc.com
www.gnpinc.com

Groschopp Inc.
420 15TH ST. NE
SIOUX CENTER, IA 51250-2100
Phone: (800) 829-4135
Fax: (712) 722-1445
www.groschopp.com

Gummi Usa
14925 STUEBNER AIRLINE
SUITE # 206
HOUSTON TEXAS 77069
Phone: (281) 444-7694
Fax: (281) 444-7964
INFO@GUMMIUSA.COM
www.gummiusa.com

Hallmark Industries Inc.
211 E. HIGGINS ROAD, UNIT H
GILBERTS, IL 60136
Phone: (847) 844-8805
Fax: (847) 844-9261
www.hallmarkind.com

Hangzhou Xingda Machinery Co. Ltd.
XINWAN INDUSTRY
XIAOSHAN, HANGZHOU ZHEJIANG
CHINA
Phone: +(86) 0571-2280-7860
Fax: +(86) 0571-2280-7855
jane@xdmade.com
www.xdmade.com

Hansen Motor Corporation
901 SOUTH FIRST STREET
PRINCETON, IN 47670-2369
Phone: (812) 385-3415
Fax: (812) 385-3013
sales@hansen-motor.com
www.hansen-motor.com

Harmonic Drive (Canada)
89 FAWNDALE CRES.
TORONTO ON M1W 2X3
CANADA
Phone: (647) 294-8847
info@harmonicdrive.ca
www.harmonicdrive.ca

Haumea Srl
VIA TREDICI NOVEMBRE 56A
VILAFRANCA DI FORLÌ
FORLÌ FC 47122
ITALY
Phone: +(39) 9543 779518
Fax: +(39) 0543 751119
info@haumea.com
www.haumea.com

Havlik Gear
455 SHELTON DRIVE
CAMBRIDGE ONTARIO N1T 2B7
CANADA
Phone: (519) 624-6240
Fax: (519) 624-4119
havlik@sympatico.ca
www.havlikgear.com

Hayes Manufacturing Inc.
P O BOX 220
FIFE LAKE, MI 49633
Phone: (231) 879-3372
Fax: (231) 879-4330
hayes@hayescouplings.com
hayescouplings.com

HBM
19 BARTLETT STREET
MARLBORO, MA 01752
Phone: (800) 578-4260
Fax: (508) 485-7480
info@usa.hbm.com
www.hbm.com

Hebei Kaidi Bearing (Group) Co., Ltd.
CHANGUAN DISTRICT
SHIJIAZHUANG HEBEI 050011
CHINA
Phone: 86-13785179568
sale@hdblbearing.com
www.hdblbearing.com

HEIDENHAIN Corporation
333 E. STATE PARKWAY
SCHAUMBURG, IL 60173
Phone: (847) 490-1191
Fax: (847) 490-3931
marketing01@heidenhain.com
www.heidenhain.com

Helium Leak Testing, Inc.
19348 LONDELINUS STREET
NORTHBRIDGE, CA 91324
Phone: (818) 349-5690
Fax: (818) 717-8584
info@heliumleaktesting.com
heliumleaktesting.com/

Henan Contrust Gear Transmission Co., Ltd.
HUACHENG INTERNATIONAL CENTER
#9 BUILDING, DAXUE ROAD,
ZHENGZHOU CHINA 450000
HENAN
Phone: +(86) 371-86075582
Fax: +(86) 371-60688757
contrust.ruby@gmail.com
www.contrust-gear.com

Hi-Grade Inc.
300 BOND STREET
ELK GROVE VILLAGE, IL 60007
Phone: (847) 640-8172
Fax: (847) 981-7839
www.higradeinc.com

Hilliard Corp., The
100 WEST FOURTH STREET
ELMIRA, NY 14902
Phone: (607) 733-7121
Fax: (607) 735-0836
www.hilliardcorp.com

Hoffmann Technics Ag
SITTERTALSTRASSE 34
ST. GALLEN SG 9014
SWITZERLAND
Phone: +41 (71) 223 2687
Fax: +41 (71) 223 2687
info@hoffmann-tech.ch
www.hoffmann-tech.ch

Houston Pump and Gear
9203 HWY 6 SOUTH # 124-353
HOUSTON, TX 77083
Phone: (832) 603-9663
Fax: (281) 344-1108
info@houstonpumpandgear.com
www.houstonpumpandgear.com/

Howdon Power Transmission Limited
PAGANHILL LANE
CAINSCROSS
STROUD GLOS GL5 4JT
UNITED KINGDOM
Phone: +44 (0) 1453 750814
Fax: +44 (0) 1453 765320
sales@howdon.co.uk
www.howdon.com

HPB Motion Control Co. Ltd.
4F, NO.120, SEC.1, SAN MIN RD.
PAN CHIAO TAIPEI 100
TAIWAN
Phone: +886-2-89645666
Fax: +886-2-89641537
motion@msa.hinet.net
www.hpb-industry.com

Huco Dynatork
MERCHANT DRIVE
HERTFORD HERTFORDSHIRE SG13 7BL
UNITED KINGDOM
Phone: +(44) 1992501900
Fax: +(44) 1992509890
david.proud@altramotion.com
www.huco.com

Hydraulic Problems ?, Inc.
PO BOX 130
784 SHIVELY CREEK RD.
DAYS CREEK, OR 97429
Phone: (541) 825-3690
Fax: (541) 825-3692
hydprobs@netzero.com
www.filterpumper.com

IADA Ltd
ALGORES WAY
WISBECH
CAMBRIDGE CAMBRIDGESHIRE PE13 2TQ
UNITED KINGDOM
Phone: +44 (0) 116 239 5099
claire.cocker@iadaldt.co.uk
www.iadaldt.co.uk

IAI America, Inc.
2690 W. 237TH STREET
TORRANCE, CA 90505
Phone: (310) 891-6015
Fax: (310) 891-0815
info@intelligentactuator.com
www.intelligentactuator.com/

IBT, Inc
9400 WEST 55TH
MERRIAM, KS 66203
Phone: (913) 261-2148
ibtinfo@ibtinc.com
www.ibtinc.com

IDC-USA
933 WESTERN DRIVE
INDIANAPOLIS, IN 46241
Phone: (317) 244-9200
Fax: (317) 244-4600
sswaim@idc-usa.com
www.IDC-USA.com

SEE OUR AD
P29

IG Watteeuw
KAMPVELDSTRAAT 51
8020 OOSTKAMP
BELGIUM
Phone: (740) 588-1722
sales@watteeuw.be
www.watteeuw.be

IMO USA Corp.
101 INNOVATION DRIVE
MC QUEEN PARK
SUMMERVILLE, SC 29483
Phone: (843) 695-6220
english.burton@goimo.com
www.imo.Industrial Clutch Parts Ltd.
UNIT 11 BINGSWOOD IND EST
WHALEY BRIDGE HIGH PEAK SK23 7LY
UNITED KINGDOM
Phone: 0044 (0) 1663 734627
Fax: 0044 (0) 1663 733023
chris@icpltd.co.uk
www.icpltd.co.uk

Industrial Friction Materials Ltd.
UNIT 7, EAST MOORS BUSINESS PARK,
EAST MOORS ROAD,
OCEAN PARK
CARDIFF SOUTH GLAMORGAN CF245JX
UNITED KINGDOM
Phone: 02920499111
Fax: 02920490011
info@industrialfriction.com
www.industrialfriction.com

Industrial Jig & Fixture
N13948 THREE MILE RD.
MINONG, WI 54859
Phone: (715) 466-4464
service@industrialjigandfixture.com
www.industrialjigandfixture.com/

Industrial Pulley & Machine Co, Inc.
P.O. BOX 35 EAST CENTER ST.
WEST MANSFIELD, OH 43358
Phone: (937) 355-4910
Fax: (937) 355-2001
steve@industrialpulley.com
www.industrialpulley.com

Inertia Dynamics, Inc.
100 FRANKLIN DRIVE / P.O. BOX 1277
TORRINGTON, CT 06790
Phone: (800) 800-6445
Fax: (860) 482-4378
sales@idicb.com
www.idicb.com

Intech Corporation
250 HERBERT AVENUE
CLOSTER, NJ 07624
Phone: (201) 767-8066
Fax: (201) 767-7797
info@intechpower.com
www.intechcorp.com

Intellidrives, Inc
28 CRICKET DR.
HOLLAND, PA 18966
Phone: (215) 728-6804
Fax: (215) 745-9459
admin@intellidrives.com
www.intellidrives.com

Interinar Electronics
14322 SKY FLOWER LN
TAMPA, FL 33626
Phone: (727) 271-0869
sales@interinar.com
www.interinar.com

International Distribution Alliance, Inc.
(IDA, In
1125 MILFORD AVENUE
ROCKFORD, IL 61109
Phone: (815) 227-9010
Fax: (815) 227-9012
sales@idamotion.com
www.idamotion.com

InvenSense
1197 BORREGAS AVENUE
SUNNYVALE, CA 94089
Phone: (408) 988-7339
Fax: (408) 988-8104
eelam@invensense.com
www.invensense.com

Involute Simulation Software Inc.
10415 DU SUPERBE
QUEBEC QC G1S 3C2
CANADA
Phone: (418) 843-6828
HyGEARS@gmail.com
www.HyGEARS.com

Isel Inc.
5266 HIGHWAY AVE
JACKSONVILLE, FL 32254
Phone: (800) 503-9533
iselinc1@gmail.com
iselinc.com

ITW Heartland
1601 36TH AVENUE
ALEXANDRIA, MN 56308
Phone: (320) 762-0138
Fax: (320) 762-1571
andy.quist@itwheartland.com
www.itwheartland.com

Jahnel - Kestermann Gmbh & Co. Kg
HUNSCHIEDSTR. 116
44789 BOCHUM, GERMANY
BOCHUM GERMANY 44789
GERMANY
Phone: +(49) 234 339 238
Fax: +(49) 234 339 330
sales@jake-gear.com
www.jake-gear.com

Jason Industrial Inc.
340 KAPLAN DRIVE
FAIRFIELD, NJ 07004
Phone: (973) 227-4904
Fax: (973) 227-1651
inquiries@jasonindustrial.com
www.jasonindustrial.com

Johnson Industries Ltd.
6500 DENNETT PLACE
DELTA BC V4G1N4
CANADA
Phone: (604) 940 4555
Fax: (604) 940 4565
derek@jbrakes.com
www.brakes.ca

JVL Industri Elektronik A/S
BLOKKEN 42
BIRKERØD 3460
DENMARK
Phone: +46 (45) 82 44 40
Fax: +45 (45) 82 55 50
hb@jvl.dk
www.jvl.dk

K+S Services
15677 NOECKER WAY
SOUTHGATE, MI 48195
Phone: (734) 374-0400
Fax: (734) 759-0082
rniesyto@k-and-s.com
www.k-and-s.com

Kamar Industries
POB 619
BUFFALO NY
Phone: (716) 549-5534
Fax: (716) 549-6595
info@kamarindustries.com
www.kamarindustries.com

Kapsyn Manufacturing Company
AUJLA ROAD,
PO MANSOORWAL DONA,
KAPURTHALA PUNJAB 144601
INDIA
Phone: +(91) 1822 237209
Fax: +(91) 1822 233452
kapsyn@vsnl.com
www.kapsyn.com

Kavlico Corporation
14501 PRINCETON AVENUE
MOORPARK, CA 93021
Phone: (805) 523-2000
Fax: (805) 523-7125
sales@kavlico.com
www.kavlico.com

Kaydon Corporation Bearings Division
2860 MCCracken STREET
MUSKOGON, MI 49441
Phone: (231) 755-3741
Fax: (231) 759-4102
bearings@kaydon.com
www.kaydonbearings.com

KB Controls
8803 SORENSEN AVE.
SANTA FE SPRINGS, CA 90670
Phone: (562) 907-7650
Fax: (562) 907-7650
sales@kb-controls.com
www.kb-controls.com

Kbk Antriebsstechnik Gmbh
info@kbk-antriebsstechnik.de
KLINGENBERG BAVARIA 63911
GERMANY
Phone: +(49) 9372-130-486-0
Fax: +(49) 9372-134-730
s.karpstein@kbk-antriebsstechnik.de
www.kbk-antriebsstechnik.de

Kilian Manufacturing Corp.
P.O. BOX 6974
1728 BURNET AVE.
SYRACUSE, NY 13217
Phone: (315) 432-0700
Fax: (315) 432-1312
dom.leo@kilianbearings.com
www.kilianbearings.com

Kinefac Corporation
156 GODDARD MEMORIAL DR.
WORCESTER, MA 01603
Phone: (508) 754-6891
Fax: (508) 756-5342
sales@kinefac.com
www.kinefac.com

Klam America Corporation
5502 PEARL STREET
DENVER, CO 80216
Phone: (800) 852-5445
Fax: (303) 297-3815
rich@klamamerica.com
www.klamamerica.com

Kleiss Gears, Inc.
390 INDUSTRIAL AVENUE
GRANTSBURG, WI 54840
Phone: (715) 598-4492
Fax: (715) 463-5996
drichter@kleissgears.com
www.kleissgears.com

Kluber Lubrication North America L.P.
32 INDUSTRIAL DRIVE
LONDONDERRY, NH 03053
Phone: (603) 647-4105
Fax: (603) 647-4106
info@us.kluber.com
www.kluber.com

KTR Corporation
122 ANCHOR ROAD
MICHIGAN CITY, IN 46360
Phone: (219) 872-9100
Fax: (219) 872-9150
ktr-us@ktr.com
www.ktr.com

SEE OUR AD
P39,40

Lab Threads & Gear Works, Inc.
515 MAIN STREET
YALESVILLE, CT 06492
Phone: (203) 949-9097
Fax: (203) 949-9697
seolabthreads@gmail.com
www.labthreads.com/

Lafert North America
5620 KENNEDY RD.
MISSISSAUGA ON L4Z 2A9
CANADA
Phone: (905) 629-1939, OR toll free
(800) 661-6413
Fax: (905) 629-2852
ptsales@lafertna.com
www.lafertna.com

SEE OUR AD
P15

LEESON Electric
1051 CHEYENNE AVENUE
GRAFTON, WI 53024
Phone: (262) 377-8810
leeson@leeson.com
www.leeson.com

LM76 Linear Motion Bearings
140 INDUSTRIAL DRIVE
E. LONGMEADOW, MA 01028
Phone: (800) 513-3163 Intl: (413)
525-4166
Fax: (413) 525-3735
mqinn@lm76.com
www.LM76.com

Lovejoy, Inc.
2655 WISCONSIN AVENUE
DOWNERS GROVE, IL 60532
Phone: (630) 852-0500
customerservice@lovejoy-inc.com
www.lovejoy-inc.com

Luoyang SBI Special Bearing Co. Ltd.
WEISI ROAD
LUOYANG INDUSTRIAL PARK
XIGONG HENAN PROVINCE
CHINA
Phone: +(86) 379-64122001
Fax: +(86) 379-64122002
judy@sbi.com.cn
www.sbibearings.com

SEE OUR AD
P10

LYC North America Inc
2600 KESLINGER ROAD UNIT H
GENEVA, IL 60134
Phone: (630) 262-0601
sales@lycbearings.com
lycbearings.com

Mach III Clutch Inc.
101 CUMMINGS DRIVE
WALTON KY 41094
Phone: (859) 291-0849
info@machiii.com
www.machiii.com/

Magnetic Technologies Ltd
POB 257
43 TOWN FOREST RD
OXFORD, MA 01540
Phone: (508) 987-3303
Fax: (508) 987-2875
sales@magnetictech.com
www.magnetictech.com

Magnum Manufacturing
39140 WEBB DRIVE
WESTLAND, MI 48185
Phone: (734) 727-0560
sales_info@magnum-mfg.com
magnum-mfg.com

Magtrol, Inc.
70 GARDENVILLE PARKWAY
BUFFALO, NY 14224
Phone: (716) 668-5555
Fax: (716) 668-8705
magtrol@magtrol.com
www.magtrol.com

Maguire Technologies
71 FERRY ROAD
SALISBURY, MA 01952
Phone: (978) 462-0701
Fax: (978) 463-3708
cdsm1@verizon.net
www.maguiretech.com

Marine Specialties, Inc.
1903 COTEAU ROAD
HOUMA LA 70364
Phone: (985) 580-1672
Fax: (985) 580-1616
chris@marinespecialties-inc.com
www.marinespecialties-inc.com

Mark Elektrijs
15, GULTEKDI INDLL., AREA
PUNE MAHARASHTRA 411037
INDIA
Phone: +(91) 20 66016312
Fax: +(91) 20 66016311
markelektrijs@vsnl.net
www.markelektrijs.com

Marshall Wolf Automation Inc.
923 SOUTH MAIN STREET
ALGONQUIN, IL 60102
Phone: (847) 658-8130
beckie@wolfautomation.com
www.wolfautomation.com

Marswell Engineering Ltd.
2/F, BLOCK C, WANG YIP CENTRE,
18 WANG YIP STREET EAST,
YUEN LONG, NEW TERRITORIES
HONG KONG
Phone: 852- 2557 9635
Fax: 852- 2897 5690
enquiry@marswell.com
www.marswell.com

Martin Sprocket & Gear
3100 SPROCKET DRIVE
ARLINGTON, TX 76015
Phone: (817) 258-3000
Fax: (817) 258-3333
mail@martinsprocket.com
www.martinsprocket.com

SEE OUR AD
P31

Master Bond, Inc.
134 HOBART ST.
HACKENSACK, NJ 07601
Phone: (201) 343-8983
Fax: (201) 343-2132
main@masterbond.com
www.masterbond.com

Matrix International
EAST MILL RD.
BRECHIN ANGUS DD9 7EP
UNITED KINGDOM
Phone: +(44) 1356602000
sales@matrix-international.com
www.matrix-international.com

Maurey Manufacturing Corporation
410 INDUSTRIAL PARK DRIVE
HOLLY SPRINGS MS 38635
Phone: (800) 284-2161
Fax: (662) 252-6364
chuckl@maurey.com
www.maurey.com

MAV S.p.A.
VIA VENEZIA 12
BOSENTINO TRENTO 38040
ITALY
Phone: 0039-0461845151 (ext.1014)
Fax: 0039-0461845150
eli.per@mav.it
www.mav.it

Mavilor Motors, S.a.
mavilor@mavilor.es
marodriguez@mavilor.es
SANTA PERP?TUA DE MOGODA BARCELONA
E-08980
SPAIN
Phone: +34 935 743 690
Fax: +34 935 743 570
mavilor@mavilor.es
www.mavilor.es

Maxon Precision Motors Inc
101 WALDRON RD
FALL RIVER, MA 02720
Phone: (508) 677-0520
Fax: (508) 677-0530
info@maxonmotorusa.com
www.maxonmotorusa.com

Mayr Corporation
4 NORTH STREET
WALDWICK, NJ 07463
Phone: (201) 788-7201
info@mayr.com
www.mayr.com

McInnes Rolled Rings
1533 EAST 12TH STREET
ERIE, PA 16511
Phone: (814) 459-4495
Fax: (814) 459-8443
sales@mcrings.com
www.mcinnrolledrings.com

SEE OUR AD
P27

Means Industries, Inc.
3715 E. WASHINGTON AVE
SAGINAW, MI 48601
Phone: (989) 754-1433
Fax: (989) 771-3396
cworkm01@meansindustries.com
www.meansindustries.com

MGT - Magnetic Gearing & Turbine Corp.
P.O. BOX 51
KARUAH NSW 2324
AUSTRALIA
Phone: +612 49 973 452
Fax: +612 49 973 073
andrew_french@mgt.com.au
www.mgt.com.au

MICO, Incorporated
1911 LEE BOULEVARD
NORTH MANKATO, MN 56003
Phone: (507) 625-6426
Fax: (507) 625-3212
micomail@mico.com
www.mico.com

Micronor Inc.
3483 OLD CONEJO RD, STE 203
NEWBURY PARK, CA 91320
Phone: (805) 499-0114
Fax: (805) 499-6585
dennis.horwitz@micronor.com
www.micronor.com

Midwest Brake
26255 GROESBECK HWY
WARREN, MI 48089
Phone: (586) 775-3000
Fax: (586) 775-3040
sales@midwestbrake.com
www.midwestbrake.com

Midwest Gear & Tool, Inc.
15700 COMMON RD.
ROSEVILLE, MI 48066
Phone: (586) 779-1300
Fax: (586) 779-6790
midwestgear@sbcglobal.net
www.powertransmission.com/cop-
age/midwestgear.htm

Midwest Motion Products
10761 AHERN AVE SE
WATERTOWN, MN 55388
Phone: (952) 955-2626
Fax: (480) 247-4096
ryanking@geartechology.com
www.midwestmotion.com

Mijno Precision Gearing
406 N. PROSPECT AVE
PARK RIDGE, IL 60068
Phone: (847) 698-9041
Fax: (847) 698-9040
mijno@aol.com
www.mijno.com

Milltex Engineering Company
B 18/39, JATPURA, NEAR BUS STAND
KAPURTHALA PUNJAB 144601
INDIA
Phone: 0091-1822-309829
Fax: 0091-1822-232909
milltex@rediffmail.com
www.beltngworld.com

Mineral Circles Bearings
P O BOX NO- 27691,
JEBEL ALI FREEZONE,
DUBAI- UAE
DUBAI EMIRATE OF DUBAI 27691
UAE
Phone: +(971) 48845100
Fax: +(971) 48845123
export@mcb.ae
www.mcb.ae

Ming Chang Traffic Parts Mfg.
NO. 13 INDUSTRY 4TH ROAD, INDUSTRY DIST.
PING TUNG CITY
TAIWAN
PING TUNG TAIWAN 900
TAIWAN
Phone: +886-8-7228056
Fax: +886-8-7229920
mccchain@ms15.hinet.net
www.mccchain.com.tw

Mini Gears (Stockport) Ltd.
TOP GEAR HOUSE
BLETCHLEY ROAD
HEATON MERSEY INDUSTRIAL ESTATE
STOCKPORT SK4 3ED
UNITED KINGDOM
Phone: 011 44 161 432 0222
Fax: 011 44 161 432 0444
enquiries@minigears.co.uk
www.minigears.co.uk

Mini-Broach Machine Company
1226 MAIN STREET
P.O. BOX 129
ASHBY, MA 01431
Phone: (978) 386-7959
minib@net1plus.com
minibroach.com/

Minsk Gear Works
UL. DOLGOBRODSKAYA, 17
220038, MINSK
BELARMINSK BELARBELAR
Phone: +375 (172) 35-52-11
Fax: +375 (172) 30-22-22
mgw@mail.ru
www.mgw.by

Mitsubishi Electric Automation, Inc.
500 CORPORATE WOODS PARKWAY
VERNON HILLS, IL 60061
Phone: (847) 478-2100
Fax: (847) 478-2396
marcomm@meau.com
www.meau.com

MMB Bearing Co. Inc.
163 ROLLING HILL ROAD
MOORESVILLE, NC 28117
Phone: (800) 526-2353
Fax: (888) 999-9017
pbarnett@mmbbearings.com
www.mmbbearings.com

Modern Linear Inc.
PO BOX 186
CORTE MADERA, CA 94976
Phone: (415) 924-7938
Fax: (415) 927-2360
info@modernlinear.com
www.modernlinear.com

Moore Gear & Mfg. Co., Inc.
#2 HAWTHORNE DRIVE
P.O. BOX 49
HERMANN, MO 65041
Phone: (573) 486-5415
Fax: (573) 486-3487
info@mooregear.com
www.mooregear.com

Motion Industries
1605 ALTON RD.
BIRMINGHAM AL 35210
Phone: (800) 526-9328
Fax: (205) 957-5290
www.motionindustries.com

Moventas Ltd.
P.O. BOX 20100
1615 BISHOP STREET NORTH
CAMBRIDGE ONTARIO N1R 8C8
CANADA
Phone: (519) 621-6390
Fax: (519) 621-7660
clay.williams@moventas.com
www.moventas.com

MROSupply
2915 EAST WASHINGTON BLVD.
LOS ANGELES, CA 90023
Phone: (888) 671-2883
Fax: (888) 671-3319
kievforyou@gmail.com
www.mrosupply.com

MT Tool & Manufacturing
1118 LUNT
SCHAUMBURG, IL 60193
Phone: (847) 985-6211
tom@mttoolinc.com
www.ourmachinist.com

NAC Harmonic Drive
4720 SALISBURY ROAD
JACKSONVILLE, FL 32256
Phone: (904) 493-6496
Fax: (904) 339-9241
info@nacharmonicdrive.com
www.nacharmonicdrive.com

Nachi America Inc.
715 PUSHVILLE ROAD
GREENWOOD, IN 46143
Phone: (317) 535-5527
Fax: (317) 535-3659
pjamerson@nachi-america.com
www.nachi-america.com/

Nanjing Cyd Precision Mach. Manu. & Sales Cent
4-304, 169 QIQINGMEN STR.,
NANJING, 210017
CHINA
NANJING JIANGSU 210017
CHINA
Phone: +(86) 139 139 75656
Fax: +(86) 25 86413490
wangjia@cydgears.com.cn
www.cydgears.com.cn

Napoleon Engineering Services
1601 JOHNSON ST.
OLEAN, NY 14760
Phone: 716-372-6532
Fax: 716-372-1448
sales@nesbearings.com
www.nesbearings.com

Nav Auxichem Pvt. Ltd
158 LEATHER COMPLEX
JALANDHAR PUNJAB 144021
INDIA
Phone: 0091-181-2650616
Fax: 0091-181-2650109
navauxichem@vsnl.net
www.perfectbelting.com

Navyug Electric Motors & Pumps Ltd
#4, PH II, GIDC, VATVA, AHMEDABAD,
GUJARAT, INDIA
AHMEDABAD GUJARAT 382445
INDIA
Phone: 00 91 79 65230103/4,
25831432/4
Fax: 00 91 79 25893435
sales@navyugelectricmotors.com;
navyugelctric@hotmail.com
www.navyugelectricmotors.com

NDE Power Transmissions
NDE BUILDINGS,
ALDBOURNE ROAD WORKS,
COVENTRY CV1 4EQ
UNITED KINGDOM
Phone: +44 (0)2476 222272
sales@ndepower.com
www.ndepower.com

Neelkanth Beltings
D-94, SPORTS & SURGICAL GOODS COMPLEX,
KAPURTHALA ROAD
JALANDHAR PUNJAB 144 021
Phone: +91 (181) 2650862
Fax: +91 (181) 2650625
info@neelkanthbeltings.com
www.neelkanthbeltings.com

Netshape Technologies, Inc.
8751 OLD STATE ROAD 60
SELLERSBURG, IN 47172
Phone: (812) 248-9273
solutions@netshapetech.com
www.netshapetech.com

New Allenberry Works (Deepak Industries Ltd.)
14/7, MATHURA ROAD
FARIDABAD
FARIDABAD HARYANA 121003
INDIA
Phone: +91-129-6451260
Fax: +91-129-2275525
gj@nawgears.com
www.allenberrygears.com/

New England Belting Company
27 MILL STREET
BERLIN, CT 06037
Phone: (860) 828-4444
Fax: (860) 828-4525
info@newenglandbelting.com
www.newenglandbelting.com

New Power Electric (USA) LLC
726 S, CASINO CENTER BLVD. #207
LAS VEGAS, NV 89101-6743
Phone: (626) 616-8999
Fax: (626) 616-8999
service@usa-newpower.com
www.usa-newpower.com

New Torque, Inc.
4909 11TH AVE. S.
MINNEAPOLIS, MN 55417
Phone: (800) 966-8325
shotton@clutches-brakes.com
www.clutches-brakes.com

Ngt Specialty Valves
P.O BOX 5223
ELM GROVE, WI 53122
Phone: (262) 782-6125
contact@ngtvalves.com
www.ngtvalves.com

Niebuhr Gears
LA COURSEVEJ 8
IKAST 7430
IKAST
Phone: +(45) 9660-5050
rni@niebuhr.dk
www.niebuhr.dk

Ningbo Zhongyi Hydraulic Motor Co. Ltd.
NINGBO ZHENHAI ECONOMIC DEVELOPMENT
ZONE
ROAD 88, ITALY
NINGBO
CHINA
Phone: +(86) 574-86261172-800
Fax: +(86) 574-86288064
sales@zihyd.com
www.zihyd.com

SEE OUR AD
P33

Nissei Corporation of America
11107-J SOUTH COMMERCE BLVD.
CHARLOTTE, NC 28273
Phone: (704) 583-0008
Fax: (704) 504-0608
gearsales@nissei-usa.com
www.nissei-usa.com

NKE Austria GmbH
ENNSER STRASSE 41A
STEYR-GLEINK UPPER AUSTRIA A4407
AUSTRIA
Phone: 0043 7252 86667
Fax: 0043 7252 86667-59
office@nke.at
www.nke.at

Nord Drivesystems
41 WEST DRIVE
BRAMPTON ON L6T 4A1
CANADA
Phone: (800) 668-4378
Fax: (905) 796-8130
kevin.zwar@nord.com
www.nord.com

North American Clutch & Driveline
P.O. BOX 15130
ROCKFORD, IL 61115
Phone: (815) 282-7960
Fax: (815) 282-9160
sales@naclutch.com
www.naclutch.com

North American Clutch Corp. (noram)
4360 N. GREEN BAY AVE.
P.O. 090228
MILWAUKEE, WI 53209
Phone: (866) 337-5906
Fax: (414) 267-4024
jeffh@noram-clutch.com
www.noram-clutch.com

Norwin Electronics Limited
UNIT 6 STATION ROAD
GAMLINGAY
SANDY BEDFORD SG19 3HB
UNITED KINGDOM
Phone: +44 (0) 1767 651485
www.norwin.co.uk
www.norwin.co.uk

Novotec Argentina SRL
AV. VELEZ SARFIELD 1560
CAPITAL FEDERAL BUENOS AIRES 1285
ARGENTINA
Phone: 5411-4303-8989
Fax: 5411-4032-0184
info@novotecargentina.com
www.novotecargentina.com

NSK Corporation
4200 GOSS ROAD
ANN ARBOR, MI 48105
Phone: (888) 446-5675
strackh@nsk-corp.com
www.nskamericas.com

SEE OUR AD
P32

Nu-Teck Couplings Pvt. Ltd
B-1, C-13, BHOSARI INDUSTRIAL ESTATE,
M.I.D.C.
PUNE MAHARASTRA 411026
INDIA
Phone: 020- 27120103, 27120104
Fax: 020- 27121223
vikman@vsnl.com
www.nuteckcouplings.com/

OEM International Inc.
575 ROUTE 73 NORTH
BUILDING B-3
WEST BERLIN, NJ 08091
Phone: (800) 636-2329
Fax: (856) 768-8717
tuck@oeminternational.com
www.oeminternational.com/

OEP Couplings, a Division of Oren Elliott Products
128 W VINE STREET
P.O. BOX 638
EDGERTON, OH 43517
Phone: (419) 298-2306
Fax: (419) 298-3545
sales@oepcouplings.com
www.oepcouplings.com/

Ondrives Ltd
FOXWOOD IND PK
FOXWOOD ROAD
CHESTERFIELD DERBYSHIRE S41 9RN
UNITED KINGDOM
Phone: +(44) 1246-455500
Fax: +(44) 1246 455522
sales@ondrives.com
www.ondrives.com

Ongears - Ondrives Export Gears
FOXWOOD IND PK
FOXWOOD ROAD
CHESTERFIELD DERBYSHIRE S41 9RN
Phone: +44 1246 455500
Fax: +44 1246 455522
ben.hinchliffe@ondrives.com
www.ongears.co.uk

Ontario Gear and Spline
3138 BONAVENTURE DRIVE
MISSISSAUGA ONTARIO L4T 2J2
CANADA
Phone: (905) 671-1813
psurray@ontariogearandspline.com
www.ontariogearandspline.com

Onvio LLC
20 NORTHWESTERN DRIVE
SALEM, NH 03079
Phone: (603) 685-0404
Fax: (603) 685-0405
shartman@onviollc.com
www.onviollc.com

Ormec
19 LINDEN PARK
ROCHESTER, NY 14625
Phone: (585) 641-2429
tmckean@ormec.com
www.ormec.com

Orttech
32425 AURORA RD.
SOLON, OH 44139-2821
Phone: (440) 498-7458
Fax: (440) 498-8268
info@orttech.com
www.orttech.com

P. G. DRIVE
123/3, SANJAY MITTAL INDUSTRIAL ESTATE
A.K.ROAD, ANDHERI-EAST
MUMBAI MAHARASTRA 400059
INDIA
Phone: +(91) 2228592806
Fax: +(91) 2228506015
pgdrive@rediff.com
www.pgdrive.com

Pacamor Kubar Bearings (pkb)
145 JORDAN ROAD
TROY, NY 12180
Phone: 518-283-8002
Fax: 518-283-8032
sales@pacamor.com
www.pacamor.com

Pacific Bearing
6402 ROCKTON ROAD
ROSCOE, IL 61073
Phone: (800) 962-8979
Fax: (815) 389-5790
marketing@pacific-bearing.com
www.pacific-bearing.com

Pacific Industries
18200 SW TETON AVE
TUALATIN, OR 97062
Phone: (800) 821-8431
Fax: (866) 552-5009
pisales@pac85.com
www.pacificindustries.com

Palmer Johnson Power Systems
1835 HAYNES DRIVE
SUN PRAIRIE, WI 53590
Phone: (608) 834-5202
Fax: (608) 834-5204
sales.wi@pjpowers.com
www.pjpowers.com

Paras Lubricants Limited
C-573, 2ND FLOOR, SARASWATI VIHAR,
OUTER RING ROAD
NEW DELHI 110034
INDIA
Phone: +91-11-27035422
Fax: +91-11-27035421
INFO@PALCO.CO.IN
WWW.PALCO.CO.IN

Parker Hannifin - SSD Drives Div.
9225 FORSYTH PARK DR.
CHARLOTTE, NC 28273
Phone: (704) 588-3246
info.us.ssd@parker.com
www.ssd drives.com

Parker Hannifin Electromechanical Automation Divis
5500 BUSINESS PARK DRIVE
ROHNERT PARK, CA 94928
Phone: 707-584-7558
tknauer@parker.com
www.parkermotion.com/

Paul's Transmission Shenzhen Co., Ltd
A300-3, HUA CAI GARDEN, 3RD FLOOR, 7
INDUSTRIAL RD, SHEKOU,
SHENZHEN-518067, CHINA
SHENZHEN GUANGDONG 518067
CHINA
Phone: 86-755-26677282
Fax: 86-755-26826245
powertransmission@chinatransmissionindustries.com
www.chinatransmission.com.cn

Peer Bearing Company
2200 NORMAN DRIVE
WAUKEGAN, IL 60085
Phone: (847) 578-1000
Fax: (847) 578-1200
info@peerbearing.com
www.peerbearing.com

Performance Gear Systems, Inc.
2400 DAVEY ROAD
WOODRIDGE, IL 60517
Phone: (630) 739-6666
Fax: (630) 739-6665
khansen@performance-gear.com
www.performance-gear.com

Pethe Engineering Private Limited
PLOT 52/53, LONAVLA INDUSTRIAL COOPERATIVE ESTATE
DISTRICT - PUNE
LONAVLA MAHARASHTRA 410401
INDIA
Phone: +(91) 2114-272570
Fax: +(91) 2114-270563
pethe_engineering@vsnl.net
www.pethe.in

Phytron, Inc.
600 BLAIR PARK RD., SUITE 220
WILLISTON, VT 05495
Phone: (802) 872-1600
Fax: (802) 872-0311
info@phytron.com
www.phytron.com

PI (Physik Instrumente) L.P. Piezo Actuator Nano
16 ALBERT ST.
AUBURN, MA MA 01501
Phone: (508) 832-3456
Fax: (508) 832-0506
info@pi-usa.www.physikinstrumente.com

PIC Design
PO BOX 1004
86 BENSON RD
MIDDLEBURY, CT 06712-1004
Phone: (800) 243-6125
Fax: (203) 758-8271
info@pic-design.com
www.pic-design.com

Pioneer Bearing Company
113-B ANGAPPA NAICKEN ST
PARRYS
CHENNAI TAMIL NADU 600 001
INDIA
Phone: +(91) 44-2533-1018
Fax: +(91) 44-3935-1992
pioneerbearing@gmail.com
www.pioneer1.com/

Pix Europe Limited
UNIT 24, FARTHING ROAD INDUSTRIAL ESTATE
SPROUGHTON IPSWICH, IP1 5AP
IPSWICH SPROUGHTON IP1 5AP
UNITED KINGDOM
Phone: 91-7104-237729, 236501-4
Fax: 91-7104-236505/6
info@pixtrans.com
www.pixeuro.com

Pix Transmissions Limited
J-7 MIDC HINGNA ROAD
NAGPUR MAHARASHTRA 440 016
INDIA
Phone: 917104237729
Fax: 917104-236505
info@pixtrans.com
www.pixtrans.com

Plastock - Putnam Precision Molding, Inc.
11 DANCO ROAD
PUTNAM, CT 06260
Phone: (860) 928-7911
Fax: (860) 928-2229
ccampbell@putnamprecisionmolding.com
www.plastockonline.com

Popular Mechanical Works
21, SATGURU NANAK INDUSTRIAL EST.
WESTERN EXPRESS HIGHWAY
GOREGOAN EAST
MUMBAI MAHARASHTRA 400063
INDIA
Phone: +(91) 22 26854126
Fax: +(91) 22 26854863
sales@popularmechworks.com
www.popularmechworks.com

Portescap
110 WESTTOWN ROAD
WEST CHESTER, PA 19382
Phone: (610) 235-5499
sales.america@portescap.com
www.portescap.com

Potomac Electric
1 WESTINGHOUSE PLAZA
BOSTON, MA 02136
Phone: (617) 364-0400
Fax: (617) 364-5477
info@potomacelectric.com
www.potomacelectric.com/

Power Engineering and Manufacturing
2635 WCF AND N DRIVE
WATERLOO, IA 50703
Phone: (319) 232-2311
Fax: (319) 232-6100
rkime@pemltd.com
www.pemltd.com

Power Transmission Engineers
I - 31, MAHALAXMI APARTMENTS
MUKTANAND, KARELIBAG
BARODA GUJARAT 390018
INDIA
Phone: +(91) 265-2462258
Fax: +(91) 265-2462258
info@ptegears.com
ptegears.com

Powermach Import & Export Co.,ltd
2709-2710 TIMES PLAZA NO.2 ZONGFU ROAD
CHENGDU SICHUAN PROVINCE CHINA 610016
CHINA
Phone: +(86) 28-86722580
Fax: +(86) 28-86725966
decen@cpt-world.com
www.cpt-world.com

Pragati Transmission Pvt Ltd
855, III STAGE, PEENYA INDUSTRIAL ESTATE
BANGALORE KARNATAKA 560058
INDIA
Phone: +(91) 80 28365364 / 0091
9341215974
Fax: +(91) 80 28365352
kadam@pragatigears.com
www.pragatigears.com

Precipart
120 FINN COURT
FARMINGDALE, NY 11735
Phone: (631) 694-3100
Fax: (631) 694-4016
sales@precipart.com
www.precipart.com

Precision Microdrives Limited
WINCHESTER HOUSE
36 WINCHESTER ROAD
WALTON-ON-THAMES SURREY KT12 2RH
UNITED KINGDOM
Phone: +44 (0) 1932 252482
Fax: +44 (0) 1932 325353
sales@precisionmicrodrives.com
www.precisionmicrodrives.com

Precision Screw Thread
S82 W19275 APOLLO DRIVE
P.O. BOX 427
MUSKEGO, WI 53150-0427
Phone: (262) 679-9000
Fax: (262) 679-9004
sales@pstcorp.net
www.precisioncrewthread.com

Precision Technologies Group (PTG) Ltd.
HOLROYD
HARBOR LANE NORTH
MILNROW
ROCHDALE LANCASHIRE OL16 3LQ
UNITED KINGDOM
Phone: +44 (0)1706 526590
Fax: +44 (0)1706 353350
neil.jones@ptgltd.com
www.ptgltd.com

Premier Udyog
8-PARTAP NAGAR
LUDHIANA PUNJAB 141003
INDIA
Phone: +(91) 9814026062
Fax: +(91) 1612545377
param0377@gmail.com
www.premierudyog.org/

Printed Motors GmbH
INDUSTRIESTR. 20
MECKESHEIM D 74909
GERMANY
Phone: +(49) 62 26 78 70 0
Fax: +(49) 62 26 78 70 29
info@printedmotors.com
www.printedmotors.com

PTD Outlet: Power Transmission Distributors
806 BAYSTAR BLVD
WEBSTER, TX 77598
Phone: (281) 280-0147
sales@ptdoutlet.com
www.ptdoutlet.com

Pulleys Manufacturers International Inc.
2980 FIRST ST. BLDG. "F"
LA VERNE CA. 91750
Phone: (951) 206-0566
Fax: (909) 981-2676
pulley@earthlink.net
www.pulleys.com

pylon Gears (Pty) Ltd
46 TENNYSON DRIVE
TULISA PARK
JOHANNESBURG GAUTENG 2136
SOUTH AFRICA
Phone: 011 613 6117
Fax: 011 623 1835
pylonsales@gearing.co.za
www.gearing.co.za

QA1 Precision Products
21730 HANOVER AVE
LAKEVILLE, MN 55044
Phone: (800) 721-7761
Fax: (952) 985-5679
sales@qa1.net
www.qa1.net/industrial

SEE OUR AD
P2

QTC Metric Gears
2101 JERICHO TURNPIKE
NEW HYDE PARK, NY 11040
Phone: (516) 437-6700
Fax: (516) 328-3343
qtcsupport@qtcgears.com
www.qtcgears.com

SEE OUR AD
P45

Quality Bearings & Components
2101 JERICHO TURNPIKE
NEW HYDE PARK, NY 11040
Phone: (516) 616-0436
Fax: (516) 616-0443
qbcsupport@qbcbearings.com
www.qbcbearings.com

Quality Reducer Service
620 EAST AVENUE
LAGRANGE, IL 60525
Phone: 708-354-8080
Fax: 708-354-8011
sales@qualityreducer.com
www.qualityreducer.com

Quality Transmission Components
125 RAILROAD AVENUE
GARDEN CITY PARK, NY 11040-5016
Phone: (516) 437-6700
Fax: (516) 328-3343
QTCSupport@qtcgears.com
www.econobelt.com

R+W America
1120 TOWER LANE
BENSENVILLE, IL 60106
Phone: (630) 521-9911
Fax: (630) 521-0366
info@rw-america.com
www.rw-america.com

SEE OUR AD
P37

Randall Publications LLC
1840 JARVIS AVE.
ELK GROVE VILLAGE, IL 60007
Phone: (847) 437-6604
Fax: (847) 437-6618
publisher@powertransmission.com
www.powertransmission.com

Rathipolybond Pty Ltd.
31,STAFFORD STREET,HUNTINGDALE
MELBOURNE VICTORIA 3166
AUSTRALIA
Phone: 61-3-95586922
Fax: 61-3-95586933
atul@rathipolybond.com
www.rathipolybond.com

Rave Gears LLC
425 STREMPLE DRIVE
SEGUIN, TX 78115
Phone: (855) 728-4327
Fax: (830) 421-3532
bruce@ravegears.com
www.ravegears.com/

RBC Bearings
ONE TRIBOLOGY CENTER
OXFORD, CT 06478
Phone: (203) 267-7001
rbc@digitalbrandexpressions.com
www.rbcbearings.com/spherical-plainbearings/index.htm

RBI Bearing Inc.
1055 STEVENSON COURT
SUITE 102W
ROSELLE, IL 60172
Phone: (800) 708-2128
Fax: (630) 295-5490
wmfuentes@rbibearing.com
www.rbibearing.com

Rdf Corporation
23 ELM AVE.
HUDSON, NH 03051
Phone: (800) 445-8367
Fax: (603) 882-6925
sensor@rdcorp.com
www.rdfcorp.com

Redex Andantex
ZI - BP 79
FERRIERES 45210
FRANCE
Phone: +(33) 2389-442-00
Fax: +(33) 2389-442-99
info@redex-andantex.com
www.redex-andantex.com

Regent Controls, Inc
1 RIVERSIDE DRIVE
ANSONIA, CT 06401
Phone: (203) 732-6200
Fax: (203) 732-6300
info@regentcontrols.com
www.regentcontrols.com

René Baer AG
FAELMISSTRASSE 3, P.O. BOX 25
SAMSTAGERN ZH 8833
SWITZERLAND
Phone: +(41) 44 787 05 55
Fax: +(41) 44 787 05 56
hello@renebaerag.ch
www.renebaerag.ch

Renk Test Systems
156 EAST HARRISON STREET
MOORESVILLE, IN 46158-1625
Phone: (317) 831-2990
kkidwell@renk.biz
www.renklabeco.com

Resistoflex Private Limited
B - 103 SECTOR 5
NOIDA
NOIDA U.P. 201301
INDIA
Phone: +(91) 98182-00364
Fax: +(91) 120-242147
sales@resistoflex.in
www.resistoflex.in

Rex Engineering Corp.
1200 CHAFFEE DR.
TITUSVILLE, FL 32780
Phone: (321) 268-5500
Fax: (321) 268-0505
rex@rex-engineering.com
www.rex-engineering.com

RGW Sales Canada
19 CHRIS COURT
HAMILTON ONTARIO L9B 1W7
CANADA
Phone: (905) 296-2039
Fax: (905) 296-6908
robert@rgwsalescanada.com
www.rgwsalescanada.com

Ringball Corporation
2160 MEADOWPINE BLVD
MISSISSAUGA ONTARIO L5N 6H6
CANADA
Phone: (905) 826-1100
Fax: (905) 826-6276
toronto@ringball.com
www.ringball.com

Ringspann Corporation
10550 ANDERSON PLACE
FRANKLIN PARK, IL 60131
Phone: (847) 678-3583
www.ringspanncorp.com

Ritbearing Corp.
744 WEST BAGLEY ROAD
BEREA, OH 44017
Phone: (800) 431-1980
Fax: (440) 234-5644
brgquote@ritbearing.com
www.ritbearing.com

RJ Link International, Inc.
3741 PUBLISHERS DRIVE
ROCKFORD, IL 61109
Phone: (815) 874-8110
Fax: (815) 874-8833
info@rjlink.com
www.rjlink.com

Rockford Linear Motion, LLC
940 SOUTHWICK DR.
ROCKFORD, IL 61102
Phone: (815) 961-7900
Fax: (815) 961-7701
info@rockfordlinearmotion.com
www.rockfordlinearmotion.com

Rockwell Automation
1201 S. SECOND ST.
MILWAUKEE, WI 53204-2496
Phone: (414) 382-2000
Fax: (414) 382-4444
www.rockwellautomation.com

Romax Technology Limited
RUTHERFORD HOUSE
NOTTINGHAM SCIENCE & TECHNOLOGY PARK
NOTTINGHAM NOTTS NG7 2PZ
UNITED KINGDOM
Phone: +44 11 59 51 88 00
Fax: +44 11 59 51 88 01
sales@romaxtech.com
www.romaxtech.com

Ronson Gears Pty. Ltd.
PO BOX 219
HIGHLAND PARK, IL 60035-0219
Phone: +1 (847) 940 4008
Fax: +(61) 395557480
enquiries@ronsongears.com.au
www.ronsongears.com

Rotek
1400 S. CHILLICOTHE RD.
AURORA, OH 44202
Phone: (330) 562-4000
Sales@rotek-inc.com
www.rotek-inc.com

Rotor Clip Company, Inc.
187 DAVIDSON AVENUE
SOMERSET, NJ 08873
Phone: (732) 469-7333
www.rotorclip.com

Rowland Co., The
4900 N. 20TH STREET
PHILADELPHIA, PA 19144-2402
Phone: (215) 455-4900
Fax: (215) 455-8888
hyost@rowland2.com
www.rowland2.com

RUBENA a.s.
sklad@rubena.cgs.cz
NACHOD 547 36
CZECHREPUBLIC
Phone: 00420-491-447-559
Fax: 00420-491-447-569
sklad@rubena.cgs.cz
www.rubena.cz

Ruland Manufacturing
6 HAYES MEMORIAL DRIVE
MARLBOROUGH, MA 01752
Phone: 508-485-1000
marketing@ruland.com
www.ruland.com

Rush Gears Inc.
550 VIRGINIA DRIVE
FORT WASHINGTON, PA 19034
Phone: (800) 523-2576
Fax: (800) 635-6273
sales@rushgears.com
www.rushgears.com

S.M. Shah & Company
107 JAYWANT INDUSTRIAL ESTATE, OPP
CROSS ROADS,
63 TARDEO ROAD
MUMBAI MAHARASHTRA 400034
INDIA
Phone: 091-22-23530391
Fax: 091-22-23520108
smshahco@rediffmail.com
www.hydraulicvanepump.com

Sallex Machine Tools
15 A, DLF INDUSTRIAL AREA
SHIVAJI MARG
NEW DELHI DELHI 110015
INDIA
Phone: 9111 25937096
Fax: 9111025167096
sallex15@gmail.com
www.sallex.com

Sam Gears India Pvt. Ltd
18/37, SITE IV SAHIBABAD
GHAZIABAD UP 201010
INDIA
Phone: 0091-120-2895728
Fax: 0091-120-2895730
sam_gears@yahoo.co.in
www.samgears.com

Schaeffler Group USA, Inc
308 SPRINGHILL FARM ROAD
FORT MILL, SC 29715
Phone: (803) 548-8500
Fax: (803) 548-8599
www.schaeffler.com

Schafer Industries
4701 NIMTZ PARKWAY
SOUTH BEND, IN 46628-6151
Phone: (574) 234-4116
Fax: (574) 239-2158
pshah@schafergear.com
www.schafergear.com

Schenck Trebel Corporation
535 ACORN STREET
DEER PARK, NY 11729
Phone: (631) 242-4010
Bernard.Bohnhorst@schenck-usa.com
www.schenck-usa.com

Schneider Electric Motion Competency Center
44191 PLYMOUTH OAKS BLVD.,
STE. 100
PLYMOUTH, MI 48170
Phone: (734) 459-8300
Fax: (734) 459-8622
info@schneidermotion.com
www.schneidermotion.com

Sensor Developments, Inc
1050 W. SILVER BELL RD
ORION, MI 48359
Phone: (248) 391-3000
Fax: (248) 391-0107
sales@sendev.com
www.sendev.com

Sensor Products Inc.
300 MADISON AVE.
MADISON, NJ 07940
Phone: (973) 884-1755
sales@sensorprod.com
www.sensorprod.com

Sensor Technology Ltd
APOLLO PARK, IRONSTONE LANE,
WROXTON
BANBURY OXFORDSHIRE OX15 6AY
UNITED KINGDOM
Phone: (44) 1869 238400
Fax: (44) 1869 238401
info@sensors.co.uk
www.sensors.co.uk

Serapid Inc.
5400 18 MILE ROAD
STERLING HEIGHTS, MI 48314
Phone: (800) 663-4514
info-us@serapid.com
www.serapid.Servometer

501 LITTLE FALLS ROAD
CEDAR GROVE, NJ 07009
Phone: (973) 785-4630
Fax: (973) 785-0756
info@servometer.com
www.servometer.com

Sesame Motor Corp.
599, SEC. 1, HEMU RD.
SHENGANG TAICHUNG 42953
TAIWAN
Phone: +(886) 4-2561-0011
www.sesamemotor.com.tw

Setco Precision Spindles, Slides & Service
5880 HILLSIDE AVENUE
CINCINNATI, OH 45233
Phone: (513) 941-5110
Fax: (513) 941-6913
sales@setcousa.com
www.setcousa.com

SEW-Eurodrive
1295 OLD SPARTANBURG HWY.
LYMAN, SC 29635
Phone: (864) 439-7537
Fax: (864) 439-7830
www.seweurodrive.com

SGF GmbH & Co. Kg
WALDKRAIBURG BAVARIA 84478
GERMANY
Phone: +49 (0) 8638 605 390
Fax: +49 (0) 8638 605 111
markus.till@sgf.de
www.sgf.de

Shivam Autotech Ltd.
303, 3RD FLOOR,
SQUARE ONE,
SAKET
NEW DELHI 110017
INDIA
Phone: +(91) 01149242100
admn@shivamautotech.com
www.shivamautotech.com

Siemens Energy & Automation
3333 OLD MILTON PARKWAY
ALPHARETTA, GA 30005
Phone: (800) 964-4114
info.sea@siemens.com
www.sea.siemens.com

Siemens Industry, Inc.
100 TECHNOLOGY DRIVE
ALPHARETTA, GA 30005
Phone: (770) 740-3928
wendy.hogan@siemens.com
www.usa.siemens.com/industry/us/en

Sinotech
6663 SW BEAVERTON-HILLSDALE HIGHWAY
PORTLAND, OR 97225
Phone: (503) 935-5222
Fax: (503) 291-6192
sinotechMotorsandMechanical@gmail.com
www.sinotech.com

SIPCO-MLS
12610 GALVESTON RD
WEBSTER (HOUSTON), TX 77598, TX 77598
Phone: (281) 480-8711
Fax: (281) 480-8656
Anull@Sipco-mls.com
www.sipco-mls.com

Siti Spa Riduttori
BOLOGNA ITALY 40050
ITALY
Phone: +390516714811
Fax: +390516714858
export@sitiriduttori.it
www.sitiriduttori.it

SKF USA Inc.
890 FORTY FOOT ROAD
LANSDALE, PA 19446
Phone: (267) 436-6000
www.skf.com

SEE OUR AD
P3

SKG Enterprises
VSP HOMES
MADHAVPURI HILLS, ROAD NO.3
CHANDANAGAR
HYDERABAD ANDHRA PRADESH 500 050
INDIA
Phone: 9000606843
skgupta@skgsons.com
www.skgsons.com

Smalley Steel Ring Company
555 OAKWOOD ROAD
LAKE ZURICH, IL 60047
Phone: (847) 719-5900
Fax: (847) 719-5999
info@smalley.com
www.smalley.com

SEE OUR AD
P26

Smart Manufacturing Technology - SMT
CHARTWELL HOUSE
67-69 HOUNDS GATE
NOTTINGHAM NG1 6BB
UNITED KINGDOM
Phone: +44 (0)115 941 9839
Fax: +44 (0)115 958 1583
info@smartmt.com
www.smartmt.com

Sokhi Heli-Wom Gears Pvt. Ltd.
61/22 SITE-4 SAHIBABAD INDUSTRIAL AREA
GHAZIABAD U.P 201010
INDIA
Phone: +(91) 01204344400
Fax: +(91) 01204168468
sokhi@gearboxindia.com
www.gearboxindia.com

Source Engineering Inc.
3283-H DE LA CRUZ BLVD
SANTA CLARA, CA 95054
Phone: (408) 980-9822
Fax: (408) 980-1860
rick@sei-automation.com
www.sei-automation.com

South Bend Gear LLC
3801 SCHAFER GEAR DRIVE
SOUTH BEND, IN 46628
Phone: (574) 968-0273
Fax: (574) 239-2158
dfozo@southbendgear.com
www.southbendgear.com

Specialty Motions, Inc.
1801 RAILROAD ST.
CORONA, CA 92880
Phone: (800) 283-3411
sales@smi4motion.com
www.smi4motion.com

SEE OUR AD
P7

SEE OUR AD
INSIDE BACK COVER

Spencer Pett 1312 Ramseur Rd.
BEESMER CITY, NC 28016
Phone: (704) 629-GEAR
www.spgear.com

Spline Gauges
PICCADILLY
TAMWORTH STAFFS. B78 2ER
UNITED KINGDOM
Phone: +44 (0) 1827 872771
mryman@inx.co.uk
SPLINEGAUGES

Spn Schwaben Praezision
GLASHUETTER STR. 2-6
NOERDLINGEN GERMANY 86720
GERMANY
Phone: +49-9081-214-0
Fax: +49-9081-214-111
info@spn-hopf.de
www.spn-hopf.de/index.php?lang=en

Sprockets Australia Pty. Ltd.
PO BOX 114
YARRAVILLE
MELBOURNE VIC 3013
AUSTRALIA
Phone: +(61) 3-9687 8177
Fax: +(61) 3-9687 8035
sales@sprocketsoz.com.au
sprocketsoz.com.au

ST Gear & Machine LLC
5304 HOPE LANE
HOUSE SPRINGS, MO 63051
Phone: (636) 677-5552
Fax: (636) 677-3652
tim@stgearandmachine.com
www.stgearandmachine.com

Star Gears
503/SOHAM, VASANT COMPLEX
MAHAVIR NAGAR
KANDIVALI - WEST
MUMBAI MAHARASHTRA 400067
INDIA
Phone: +(91) 9920790777
stargears@gmail.com
www.stargears.in

Stearns Division / Rexnord Industries Inc.
5150 S. INTERNATIONAL DRIVE
CUDAHY, WI 53110
Phone: (414) 272-1100
Fax: (414) 277-4364
raymond.mazurek@rexnord.com
stearns.rexnord.com

Stelmans Broaches Pvt Ltd
183 AJIT NAGAR
PATIALA PUNJAB 147001
INDIA
Phone: (91) 175-2218031
Fax: (91) 175-2212963
info@stelmans.com
www.stelmans.com

Steinmeyer Inc.
56 MIDDLESEX TURNPIKE
SUITE 200
BURLINGTON, MA 01803
Phone: (781) 273-6220
Fax: (781) 273-6602
jskaltsas@steinmeyer.com
www.steinmeyer.com

Stellar Technology, Inc.
237 COMMERCE DRIVE
AMHERST, NY 14228
Phone: (716) 250-1900
sales@stellartech.com
www.stellartech.com

Stephenson Gobin Transmissions
HIGH ETHERLEY
BISHOP AUCKLAND COUNTY DURHAM DL14
OHY
Phone: 0044 1388832252
enquiries@stephensongobin.com
www.stephensongobin.com

Sterling Instrument
2101 JERICHO TURNPIKE
NEW HYDE PARK, NY 11040
Phone: (516) 328-3300
Fax: (516) 326-8827
sdp-sisupport@sdp-si.com
www.sdp-si.com

SEE OUR AD
BACK COVER
P42,45

Stieber Clutch
HATSCHKESTR 36
HEIDELBERG 69126
GERMANY
Phone: 49(0)62213047.0
Fax: 49(0)6221304731
sales@stieber.de
www.stieber.de

Stober Drives, Inc.
1781 DOWNING DRIVE
MAYSVILLE KENTUCKY 41056
Phone: (606) 759-5090
Fax: (606) 759-5045
sales@stober.com
www.stober.com

Stock Drive Products
2101 JERICHO TURNPIKE
NEW HYDE PARK, NY 11040
Phone: (516) 328-3300
Fax: (516) 326-8827
sdp-sisupport@sdp-si.com
www.sdp-si.com

SEE OUR AD
BACK COVER
P35,40

Suhner Manufacturing Corp.
HWY. 411 S/SUHNER DRIVE
P.O. BOX 1234
ROME, GA 30162-1234
Phone: (706) 235-8046
Fax: (706) 235-8045
transmission@suhner.com
www.suhner.com/transmission

Sumitomo Machinery Corp. of America
4200 HOLLAND BOULEVARD
CHESAPEAKE, VA 23323
Phone: (757) 485-3355
Fax: (757) 487-3193
customercare@suminet.com
www.smcyclo.com

Supreme Gear Co.
17430 MALYN BLVD.
FRASER, MI 48082
Phone: (586) 294-7625
Fax: (586) 294-7648
info@supremegear.com
www.supremegear.com

Suzhou Asia Pacific Metal Co., Ltd.
NO.4 XINGWANG ROAD
SUZHOU JIANGSU 215132
CHINA
Phone: (86) 136-16204136
Fax: (86) 512-88186188
upben@263.net
www.szapmc.com

SYX Bearing
SHANGHAI, CHINA
SHANGHAI, CHINA
CHINA
sophia@syxbearing.com
www.syxbearing.com

T.E.A. Machine Components
2281 F DABNEY RD.
RICHMOND, VA 23230
Phone: (804) 342-0004
Fax: (804) 342-0006
sales@teausa.net
www.teausa.net

Taiwan Precision Gear Corp.
NO. 136-2, ALLEY 5, LANE 123, SHOU PI
FENG YUENG CITY TAICHUNG 420
TAIWAN
Phone: (886) 425351329
Fax: (886) 425351467
tpgcorp@ms13.hinet.net
www.tpg-tw.com

Taizhou Heri Autoparts Co. Ltd.
ROOM 1707, NO 127 CHANGSHOU ROAD
SHANGHAI 200060
CHINA
Phone: +(86) 21 62773282
Fax: +(86) 21 62773283
office@heri-sh.com
www.heri.net.cn

Tapeswitch Corporation
100 SCHMITT BLVD.
FARMINGDALE, NY 11735
Phone: (631) 630-0442
Fax: (631) 630-0454
nallison@tapeswitch.com
www.tapeswitch.com

TB Wood's
440 NORTH FIFTH AVE.
CHAMBERSBURG, PA 17201
Phone: (888) 829-6637
Fax: 7172646420
info@tbwoods.com
www.tbwoods.com

Team Industries
18880 DAN STREET
DETROIT LAKES, MN 56501
Phone: (218) 847-9582
Fax: (218) 847-1052
info@team-ind.com
www.team-ind.com

Technico
766 NORTH RIVER RD
NW WARREN, OH 44483
Phone: (330) 847-7000
www.technico.com

Tecnotion BV
P.O. BOX 23
ALMELO OV 7600 AA
NETHERLANDS
Phone: 0031 546 536300
Fax: 0031 546 536310
sales@tecnotion.com
www.tecnotion.com

Teco Westinghouse
260 WINDSOR GATE COVE
ATLANTA, GA 30342
Phone: (404) 229-8738
Fax: (512) 248-5617
richardr@tecowestinghouse.com
www.tecowestinghouse.com

Tef - Cap Industries
1109 DEBRA'S WAY
WEST CHESTER, PA 19382
Phone: (610) 692-2576
TefCapInd@TefCap.com
www.TefCap.com

TelcoMotion
9812 WHITHORN DR.
HOUSTON, TX 77095
Phone: (281) 855-2218
Fax: (281) 859-8825
motors@telcointercon.com
www.telcointercon.com

Test Equipment Connection
30 SKYLINE DRIVE
LAKE MARY, FL 32746
Phone: (407) 804-1299
Fax: (407) 804-1277
business4@testequipmentconnection.com
www.testequipmentconnection.com

Timothy Holding Co., Ltd.
#55 JINSHI ROAD, LECHENG INDUSTRIAL PARK
YUEQING CITY ZHENGJIANG
CHINA
Phone: +(86) 137-5889-7904
august@timothyholding.com
www.timothyholding.com

Toledo Gearmotor A Bluffton Motor Works Company
5439 ROAN ROAD
SYLVANIA, OH 43560
Phone: (800) 488-7072
Fax: (419) 885-3799
customerservice@toledogear.com
www.toledogear.com

Tolomatic, Inc.
3800 COUNTY ROAD 116
HAMEL, MN 55340
Phone: (800) 328-2174
Fax: (763) 478-8080
sales@tolomatic.com
www.tolomatic.com

Tool Masters India
C-36 FOCAL POINT
PATIALA PUNJAB 147003
INDIA
Phone: 0091-175-2232808
Fax: 0091-175-5001405
toolmasters@gmail.com
www.tool-masters.com

Top Machinery & Equipment (Zhengzhou) Ltd
10-1509#, 73 WEILAI ROAD,
ZHENGZHOU HENAN 450008
CHINA
Phone: (86) 371-65523361
Fax: (86) 371-65614031
export@top-rol.com
www.top-rol.com

Torque Transmission
1246 HIGH STREET
FAIRPORT HARBOR, OH 44077
Phone: (440) 357-8135
Fax: (440) 352-7682
www.torquetrans.com

Transply Inc.
P.O. BOX 7727
YORK, PA 17404
Phone: (717) 767-1005
Fax: (717) 767-9410
sales@transply.com
www.transply.com

Tristate Bearing & Supply Co. Inc.
14 SEBAGO STREET
CLIFTON, NJ 07013
Phone: (201) 794-3838
Fax: (201) 794-3237
sales@tristatebearing.com
www.tristatebearing.com

Triumph Gear Systems - Acr Industries
15375 23 MILE ROAD
MACOMB, MI 48042-4000
Phone: (586) 781-2800 ext. 8750
Fax: (586) 677-8134
jlonganbach@triumphgroup.com
www.triumphgroup.com

Trojon Gear Inc.
418 SAN JOSE STREET
DAYTON, OH 45403
Phone: (937) 254-1737
Fax: (937) 254-3029
timwhite@trojon-gear.com
www.trojon-gear.com

TSS Rotterdam B.V.
P.O. BOX 12012
ROTTERDAM 3004 GA
THE NETHERLANDS
Phone: +(31) 10 4624500
Fax: +(31) 10 4626240
info@tssr.nl
www.tssr.nl/products/item230

Tsubaki of Canada Limited
1630 DREW ROAD
MISSISSAUGA ON L5S 1J6
CANADA
Phone: (905) 676-0400
Fax: (905) 676-0904
agawaran@tsubaki.ca
www.tsubaki.ca

TVT America, Inc.

210 EAST MAIN STREET
HOLDENVILLE OK 74848
Phone: (866) 285-5055
Fax: (866) 768-4927
sales@tvtagamerica.com
www.tvtagamerica.com

Twiflex Limited

104 THE GREEN
TWICKENHAM MIDDLESEX TW12 5AQ - UK
UNITED KINGDOM
Phone: 442088941161
Fax: 442088946056
sales@twiflex.com
www.twiflex.com

Unigear Industries

20375 CLARK GRAHAM
BAIE D'URFE QUEBEC H9X 3T5
CANADA
Phone: (514) 457-7700
roberth@unigear.com
www.unigear.com

V2 Engineering Systems

45, 3RD MAIN, MARUTHI LAYOUT, VASAN-
THAPURA,
BANGALORE KARNATAKA 560061
INDIA
Phone: +(91) 8032471858
engineering@v2engineeringsys-
tems.com
www.v2engineeringsystems.com

Var-Spe Variatori Oleodinamici

VIA CORDELLINA 81
TAVERNELLE DI ALTAVILLA
VICENTINA VICENZA 36077
ITALY
Phone: +(39) 0444-572011
Fax: +(39) 0444-573188
caterina@varspe.com
www.varspe.com

VCST LP

INDUSTRIEZONE SCHURHOVENVELD 3025
3800 ST.-TRUIDEN
SINT-TRUIDEN LIMBURG 3800
BELGIUM
Phone: 32-11670432
krispeetermans@vcst.be
www.vcst.be

Venture Products International

27 MULVANEY STREET
ASHEVILLE, NC 28803
Phone: (828) 285-0495
info@ventureproducts.com
www.ventureproducts.com

Vibracoustics Ltd

UNIT 1 BROOK HOUSE
CROSS STREET
SYSTON
LEICESTER LEICESTERSHIRE LE7 2JG
UNITED KINGDOM
Phone: +44 (0) 116 2605700
Fax: +44 (0) 116 2605707
mail@vibracoustics.com
www.vibracoustics.com

Vision International

127-227, KARMA ESTATE, NR. TRIKAMPURA
PATIA,
GIDC VATVA,
AHMEDABAD GUJARAT 382445
INDIA
Phone: +(91) 9374160151
Fax: +(91) 7940084543
netexim@gmail.com
www.engimech.com

Vision Quality Components, Inc

1433 INDUSTRIAL PARK ROAD
CLEARFIELD, PA 16830
Phone: (614) 833-4489
ernie@visionqci.com
www.visionqci.com

VL Motion Systems Inc.

2316 DELAWARE AVE. #229
BUFFALO, NY 14216-2687
Phone: (866) 267-8077
Fax: (888) 217-7926
info@vlmotion.com
www.vlmotion.com

Volta Belting

11 CHAPIN ROAD
PINEBROOK, NJ 07058
Phone: (973) 276-7905
Fax: (973) 276-7908
pierrec@spc-volta.com
voltabelting.com

Vortex Engineering Works

PLOT B-3, PHASE-II, M.I.D.C.
DOMBIVLI - 421 204
THANE MAHARASHTRA 421204
INDIA
Phone: +91-251-
2871339,6571451,6574451
Fax: +91-251-2870044
sales@vortex-clutch.com
www.vortex-clutch.com

VW Broaching Service Inc.

3250 W. LAKE ST.
CHICAGO, IL 60624
Phone: (773) 533-9000
Fax: (773) 533-0763
sales@vwbroaching.com
www.vwbroaching.com

Warner Linear

6593 REVLON DR.
PLANT 1
BELVIDERE, IL 61008
Phone: 800-825-6544
Fax: 815-547-7206
info@warnerlinear.com
www.warnerlinear.com

WD Bearing America

1490 BERNARDE DR. UNIT A
ADDISON, IL 60101
Phone: (630) 613-9792
Fax: (630) 613-9917
www.wd-bearing.com

WEG

6655 SUGARLOAF PARKWAY
DULUTH, GA 30097
Phone: (800) 275-4934
www.weg.net

Wellman Wacoma Limited

TIVOLI PARK, BUNGALOW NO. 5,
225 B A.J.C. BOSE ROAD
KOLKATA WEST BENGAL 700020
INDIA
Phone: +91-33-22837389 /
32918313
Fax: +91-33-22836080
wellmanwacoma@wellmanwa-
coma.com
www.wellmanwacoma.com

Whittet-Higgins Company

33 HIGGINSON AVENUE
CENTRAL FALLS RHODE ISLAND, 02863
whittet-higgins.com

Windsor Exports

MANDEEP ESTATE BEHRAMPUR ROAD
KHANDSA
GURGAON HARYANA 122001
INDIA
Phone: (91) 124-4323900
Fax: (91) 124-4323998/999
gearindia@india.com
www.gearindia.com

Winzeler Gear

7355 W. WILSON AVENUE
HARWOOD HEIGHTS, IL 60706
Phone: (708) 867-7971
Fax: (708) 867-7974
jwinzeler@winzelergear.com
www.winzelergear.com

Wittenstein (formerly alpha gear drives)

1249 HUMBACHT CIRCLE
BARTLETT, IL 60103
Phone: (630) 540-5300
Fax: (630) 736-6100
info@wittenstein-us.com
www.wittenstein-us.com

WMH Transmissions Ltd

WMH TRANSMISSIONS LTD
24 CAVENDISH, LICHFIELD ROAD INDUSTRIAL
ESTATE
TAMWORTH STAFFORDSHIRE B79 7XH
UNITED KINGDOM
Phone: 0044 1827 310311
Fax: 0044 1827 307118
sales@wmh-trans.co.uk
www.wmh-trans.co.uk

Worldwide Electric Corp.

1 GROVE ST. #201B
PITTSFORD, NY 14534
Phone: (800) 808-2131
Fax: (800) 711-1616
www.worldwideelectric.net

SEE OUR AD
P34**WPT Power Corporation**

PO BOX 8148
WICHITA FALLS TEXAS 76307
Phone: (940) 761-1971
Fax: (940) 761-1989
mckelvey@wptpower.com
www.wptpower.com

Wyko - London & Overseas Supplies

UNIT G, CRACKLEY WAY,
PEARTREE LANE
DUDLEY DY2 0UW
UNITED KINGDOM
Phone: +44 1384 246230
Fax: +44 1384 246240
landos@wyko.co.uk
www.wyko.co.uk

Xtek, Inc.

11451 READING ROAD
CINCINNATI, OH 45241
Phone: (513) 733-2800
Fax: (513) 733-2989
david.treglia@xtek.com
www.xtek.com

Xuzhou BeiLai Engineering Machinery Co., Ltd

NO 1. XINDA ROAD, THIRD INDUSTRIAL PARK
,DISTRICT OF TONGSHAN, XUZHOU CITY,
CHINA
XUZHOU JIANGSU 221112
CHINA
Phone: +(86) 516-85656717
Fax: +(86) 516-85851577
xzbl99@126.com
www.xzbeilai.com

Xuzhou Topware Slewing Bearings Co.,Ltd

ZHANGJI MINE-COAL SQUARE 13#
XUZHOU JIANGSU 221140
CHINA
Phone: +(86) 516 85366778
Fax: +(86) 516 85366777
sales@xztopware.com
www.xztopware.com

Yaskawa America, Inc.

DRIVES & MOTORS DIVISION
2121 NORMAN DRIVE SOUTH
WAUKEGAN, IL 60085
Phone: (800) 927-5292
Fax: (847) 887-7310
tom_kutcher@yaskawa.com
www.yaskawa.com

SEE OUR AD
P19**Yieh Chen Machinery (Six Star Group)**

NO. 112, BAOSHENG RD.,
CHANGHUA CITY 50089
TAIWAN
Phone: +(886) 4-7221234
Fax: +(886) 4-7265265
rebecca@yiehchen.com
www.yiehchen.com

Yogi Bearings

6 VATIKA COMPLEX, NEAR DR. VASANI
LIMDA LANE
JAMNAGAR GUJARAT 361001
INDIA
Phone: +(91) 989-8346053
Fax: +(91) 288-2664053
ybearings@yahoo.co.in
www.yogibearings.com

Zeon Belts Pvt. Ltd.

797 URBAN ESTATE PHASE II
JALANDHAR PUNJAB 144022
INDIA
Phone: +(91) 96468-11061
Fax: +(91) 181-2271897
manav@zeonbelts.com
www.zeonbelts.com

Zerelli Technologies Inc

PARK WEST FINANCE STATION
PO BOX 20953
NY, NY 10025
Phone: (212) 721-6769
Fax: (212) 721-6879
nick.penze@zerelli.com
www.zerelli.com

Zero-Max

13200 SIXTH AVENUE NORTH
MINNEAPOLIS, MN 55441
Phone: (763) 546-4300
Fax: (763) 546-8260
sales@zero-max.com
www.zero-max.com

ZRIME

NO. 81 SONGSHAN SOUTH ROAD
ZHENGZHOU HENAN 450052
CHINA
Phone: +(86) 371-67710564
Fax: +(86) 371-67710565
cheny@zrime.com.cn
www.zrime.com.cn

ZZN Transmission Plant

23 GRABSKIEGO STREET
STALOWA WOLA 37-450
POLAND
Phone: +48 15 813 50 53 / +48 15
813 58 45
Fax: +48 15 813 42 69
zzn@liugongpl.com
www.zzn-transmissions.com

Pre-Tension Thrust Bearings

THE QUESTION

What is the recommended method of gripping a spinning shaft (with up to 130 hp of rotational energy) to install pre-tension thrust bearings and conventional thrust bearings (load = hundreds of pounds) when the shaft cannot have any high points because it must pass through an area of tight clearances to assemble? Will snap rings still withstand the harsh vibration of this environment?

Expert response provided by Norm Parker, bearing technical specialist for the driveline division at GM Milford (MI) Proving Grounds

Despite their unassuming demeanor, retaining rings are big business. Their relatively easy production—in addition to their massive global demand—make for an attractive market for many small manufacturers.

Retaining rings come in just about every shape and size imaginable, but we can break them into two main groups: internal and external.

Internal rings are installed on an internal housing bore; these are frequently used to retain a seal or bearing in a housing.

External rings—or rings that install on an outer diameter—are commonly used on shafts. The primary function of this style is to locate bearings, gears or other components on a rotating shaft. These are available in radial and axial installation styles, often referred to as “C” clips.

Retaining rings are available for just about every duty cycle needed—from lightweight retaining rings to rings that can hold several hundred thousand pounds of axial load.

The two main considerations in designing for a loaded retaining ring is the load capability of the retaining ring and the load capability of the groove the ring will be located in. Often, the groove is the weak point in the system.



Figure 1 Internal retaining ring.

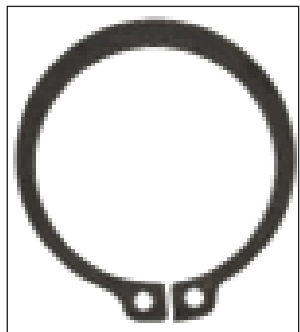

Figure 2 External axial retaining ring.

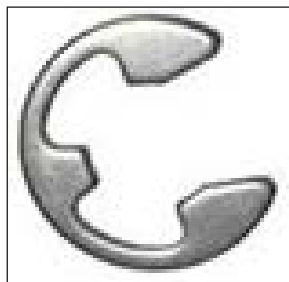

Figure 3 External radial retaining ring.

All of the recommended groove dimensions and tolerancing will be listed for every snap ring in any basic catalog.

While all of the dimensions will be listed in the catalog for every retaining ring, it is often useful to do a little work up front to make some loose determination on what size ranges you will be looking at. The equations for ring shear and groove deformation can literally be done in a few minutes.

Based on the magnitude of load and precision needed, a wide range of thicknesses, precision and styles are available. However, many heavy-duty applications supporting full gear loads, clutch reactions, wheel ends, primary drive shafts, and many others use retaining rings in situations where solid shoulders on shafts and housings are not practical or feasible.

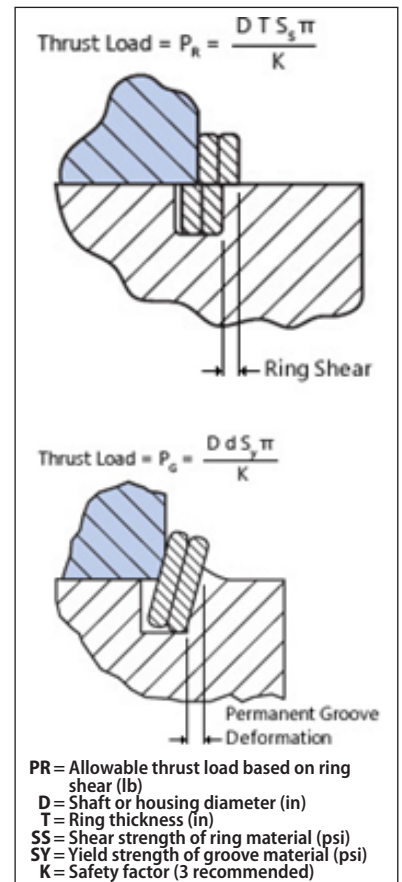

Figure 4 Groove deformation equation.

As a GM bearing technical specialist, **Norm Parker** is tasked with testing theoretical models in the real world, in real time. In keeping with his strong academic background, Parker has also developed a keen interest in the commercial and engineering aspects of the bearing industry. Parker plans to continue expanding his expertise and providing substantial personal contributions to bearing technology through metallurgy, design and processing.



Hungry for More?



Everything you need if you buy gears, bearings, motors, couplings and clutches.

Power Transmission Engineering

- Product and Industry News Updated Daily
- Directory of Mechanical Power Transmission Suppliers
- Exclusive online content in our e-mail newsletters
- Back Issues and Article Archive
- Calendar of Upcoming Events for power transmission professionals

FREE SUBSCRIPTION!

www.powertransmission.com

The Applications of Bevel Gears

Dr. Hermann J. Stadtfeld

EDITORS' NOTE: *"The Applications of Bevel Gears" is the excerpted third chapter of Dr. Hermann Stadtfeld's latest book — Gleason Bevel Gear Technology (The Gleason Works, Rochester, New York, USA; All rights reserved. 2014; ISBN 978-0-615-96492-8.), which appears here unabridged through the kind graces of Dr. Stadtfeld and Gleason Corp. Future installments will appear exclusively in Power Transmission Engineering and Gear Technology magazine over the next 12 to 18 months.*

A Word From the Author

Much has occurred in our industry over the past 10 to 15 years. A singular example is the heightened complexity — and opportunity — that now exists in making "best choices" for optimal transmission elements.

Indeed — 21st Century gear technology not only offers methods for the calculation and manufacture of classical bevel and hypoid gears; it also now presents a variety of possibilities for the three-dimensional transmission of power via gear types that — once-upon-a-time — could only be manufactured on special machines with exotic, expensive tools.

This book was written and is intended for specialists in Planning, Engineering, Gear Design and Manufacturing. It also serves to help meet the technical information needs of those researchers, scientists and students who deal with the theory and practice of bevel gears and other angular gear systems on a regular basis.

What's more, Gleason Bevel Gear Technology is the first multi-translated textbook available worldwide that goes beyond explicating the abovementioned methods. It also imparts practical suggestions for their application.

The basics-oriented, introductory chapters of this book guide both engineers and students with no gear experience in an easy, reader-friendly way through the basics of modern cylindrical and bevel gear technology. A vector math is introduced that enables every gear specialist to create an Excel spreadsheet and conduct their own experiments in order to gain a better understanding of the complex bevel gear geometry.

It must be noted and acknowledged that The Gear Praxis — published by Karl Friedrich Keck in 1958 — is the inspiration for this book; it describes, in comprehensive detail, bevel gear technology from a mid-20th-Century perspective. Indeed, The Gear Praxis in turn inspired me to write this book, addressing all aspects of the state of actual bevel gear technology — but with an early 21st Century perspective.

Introduction

An introduction to gear theory and the fundamental, gear-mathematical explanations required to understand the geometry of bevel gears has been provided in the preceding chapters. Thus informed, Chapter 3 will introduce examples of everyday applications in the industry that serve to estab-

lish the basis for the practical-oriented chapters to come. Similar to cylindrical gears — used to reduce the RPM of a prime mover and to bridge the distance between gear shafts (parallel axes) — bevel gears are also used to reduce input RPM and to transmit motion between two axes that include an angle which can be not just 90°. This physical property of bevel gears allows the orientation between input and output shaft to be under almost any angle. The results translate to design solutions for industrial gear boxes, vehicles and aircrafts which are — due to their use of bevel gears — less complex and best-performing in their function.

Automotive

Luxury-market automobiles have optimal traction due to sophisticated weight distribution design and a "pushing" — rather than "pulling" — propulsion. A longitudinally installed engine drives via manual or automatic transmission a propeller shaft whose rotation is re-directed in the direction of the driving rear wheels by a bevel gearset with pinion shaft offset; i.e. — a hypoid gearset. In addition to enhanced



Figure 1 Rear-axle-drive of a passenger car (Source: Daimler AG).



Figure 2 Shows a luxury vehicle with longitudinally oriented combustion engine and a driven rear axle. This concept is used by all automobile manufacturers worldwide on luxury-class vehicles that feature one driven axle.

weight distribution and ideal vehicle handling, the common, disturbing tilt motion and “torque steer” — as in cases of fast gas pedal actuation — are eliminated. While it is more cost-effective to manufacture front-wheel-drive vehicles with “east/west-oriented” engines, these vehicles present for the operator a combination of disadvantages which include, along with handling, higher fuel consumption.

The cross-section of a typical passenger car rear-axle drive unit is shown in Figure 1. The input shaft offset positions the pinion below the ring gear axis; the input is on the right side and comes from the propeller shaft. Both flanges in front of and behind the ring gear will be connected to the rear wheels with driveshafts. The differential carrier with four straight bevel gears is located inside the ring gear. The two differential gears, which are on the ring gear axis, are rigidly connected to the drive flanges. The two radially oriented differential gears are connected with center pins to the differential carrier on which the ring is rigidly bolted. This configuration enables different RPM of the two driving wheels — while the vehicle is negotiating curves, for example — where the wheel towards the inside of the curve requires a lower number of revolutions than the outside wheel. (Fig. 2 shows a luxury-class vehicle with a longitudinally oriented combustion engine and driven rear axle. This concept is used by automobile manufacturers worldwide on luxury-class vehicles that feature one driven axle.)

Maximum traction is achieved in every vehicle if all wheels are driven; i.e. — all-wheel-drive (AWD) automobiles. Figure 3 shows the drive units of a vehicle with a longitudinally oriented engine and a transmission with a propeller shaft connection to the rear axle. In addition, a transfer case is mounted to the transmission exit that transfers rotation from the transmission exit to the front axle drive. Typically, transfer cases feature mechanical and electromechanical components that allow for differences in RPM and load between the front and rear axle. This is required in order to accommodate a variance in slippage between front and rear axle without winding up the geartrain, as well as the transmission of different torques to the front and rear axle. Eighty percent of the bevel gears in passenger cars are ground, while the remaining 20% are lapped.

Light and Heavy Trucks

Starting with light trucks, those with one-ton payloads are usually driven by one rear axle — with one bevel gearset in each axle unit. For both light *and* heavy trucks, the propulsion via the rear axle is considered the standard solution, while all-wheel-drive solutions are optionally available. Commercial trucks use rigid-beam-style axles, where the central transmission housing is welded to the axle tubes. The beam-style axles carry the brake mechanism in the wheel area and are connected to the truck frame with control arms. The driveshafts and their bearings are located within the axle tubes. The driveshafts have at their end, where they protrude beyond the tubes, flanges with the wheel interface. This simple design — as it is applied to trucks — shows no disadvantages. To the contrary, it is a solution that even offers good off-road capabilities.

Figure 4 shows a pick-up truck with 2.5-ton payload and a rigid-driven rear axle; the vehicle in Figure 5 is an AWD sport

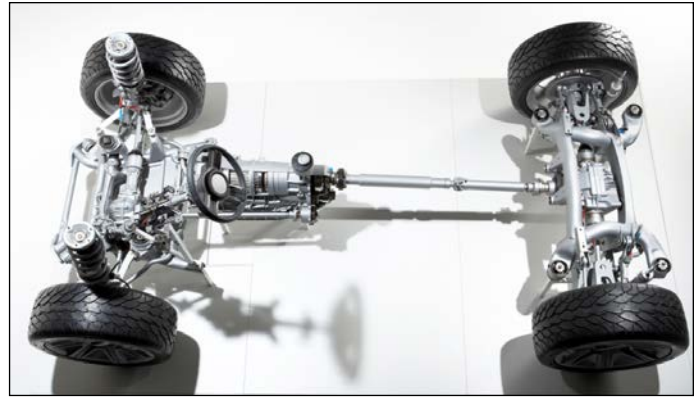

Figure 3 Drive components of a vehicle with all-wheel drive (Source: ZF Friedrichshafen AG).



Figure 4 Light truck (Source: General Motors Corporation).



Figure 5 Sport Utility Vehicle (Source: Chrysler Group LLC).



Figure 6 Class 8 semi-truck, tractor with tandem axle.

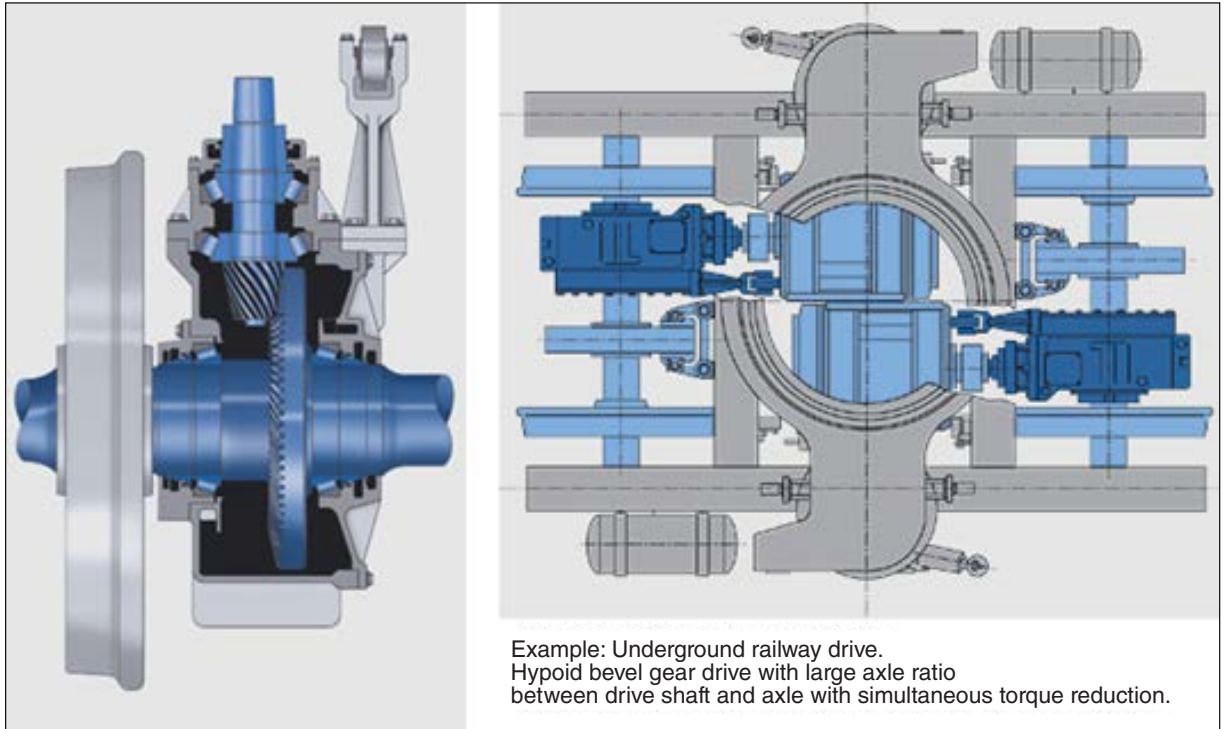

Example: Underground railway drive.
Hypoid bevel gear drive with large axle ratio
between drive shaft and axle with simultaneous torque reduction.

Figure 7 Drive components of a driven subway car.



Figure 8 Backhoe.



Figure 9 Excavator and scraper (Source: Liebherr).

utility vehicle (SUV). Of additional interest is that even this mixture between light truck and station wagon is mostly equipped with a beam-style rear axle, and a driven, beam-style steering axle in the front.

The tractor of the Class 8 semi-truck in Figure 6 has under the trailer pivot a driven-tandem axle; the tandem axle consists of two independent, frame-connected, beam-style axles. The first is connected to the transmission and engine with a propeller shaft, while the second axle is connected with a short propeller shaft to a transfer case located in the housing of the first axle. The transfer case has a fixed ratio that precludes slippage between the axles.

Eighty percent of the bevel gears in commercial trucks are lapped after heat treatment as a hard finishing process, while 20% are ground.

Railroad Drives

Railroad engines powered with electric motors or diesel engines feature large, longitudinally oriented prime movers whose rotation and torque are transmitted to the wheel axles with driveshafts and bevel gear transmissions.

With trolleys, subway cars or commuter trains, smaller individual, electric motors are dedicated to each axle. Also, the longitudinal motor orientation is preferred and a redirection of the motion is realized by bevel gear transmissions (Fig. 7). The bevel gearsets are ground or skived after heat treatment.

Construction Equipment

Earth-moving equipment uses bevel gears for auxiliary purposes, as well as for their propulsion. The backhoe shown in Figure 8 is very similar to a farm tractor in its basic design concept. Backhoes feature a driven, beam-style rear axle with a spiral bevel gearset (no hypoid offset). Engine, shift trans-

mission and axle drive are connected in these tractors to one solid unit.

The excavator in Figure 9 (top) has four driven, dual wheels. Engine and transmission are located in the upper-rotatable operator cabin. The propulsion of the wheels is produced from the transmission via a bevel gearset to a vertical shaft through the center of the cabin pivot point; it is then redirected beneath the suspension frame with a second bevel gearset in the horizontal length direction. Two propeller shafts transmit the drive motion to each of the front and rear beam axles. The two beam axles also include bevel gearsets for the motion redirection to the wheel axles.

Modern scrapers, i.e. — bulldozers (Fig. 9, bottom) — apply hydrostatic-powered track chains; bevel gears are used only for the actuation of auxiliary units. Bevel gears in construction equipment are — depending upon their manufacture — either lapped, ground, skived or built — without any hard finishing operation after heat treatment.

Aviation

Jet airplane engines have all moving engine parts oriented around the main shaft. The connection of the turbine rotors is established with Curvic couplings. Auxiliary units require a power take-off from the main shaft, which is accomplished via bevel gear transmissions (Fig. 10).

Helicopters use internal combustion, or jet, engines. Modern jet engines for airplanes are designed as a turbofan, where the rotational power of the main shaft — which is generated behind the combustion chambers — is partially used to compress the air that flows into the combustion chambers, and partially to rotate one or several fans. This generates additional thrust to the thrust already generated at the engine exit. Helicopters for civil applications generate lift and thrust forces solely with the main rotor, which is why helicopter jet engines are designed to deliver all output energy on the main shaft, which in turn is used to power the main rotor instead of a turbofan. In both cases, piston or jet engine, there is a necessary redirection of the rotation from the near-horizontally oriented output shafts to the vertical direction of the main rotor axis.

The high, maximal RPM of 18,000 in cases of one or two turbines is reduced with a first bevel gearset by a factor of three, and further reduced by a factor of four-to-eight with the main rotor drive. The main rotor drive has a large ring gear — 80 to 120 teeth — that is driven by one or two pinions (depending on the number of engines). Additional pinions are grouped

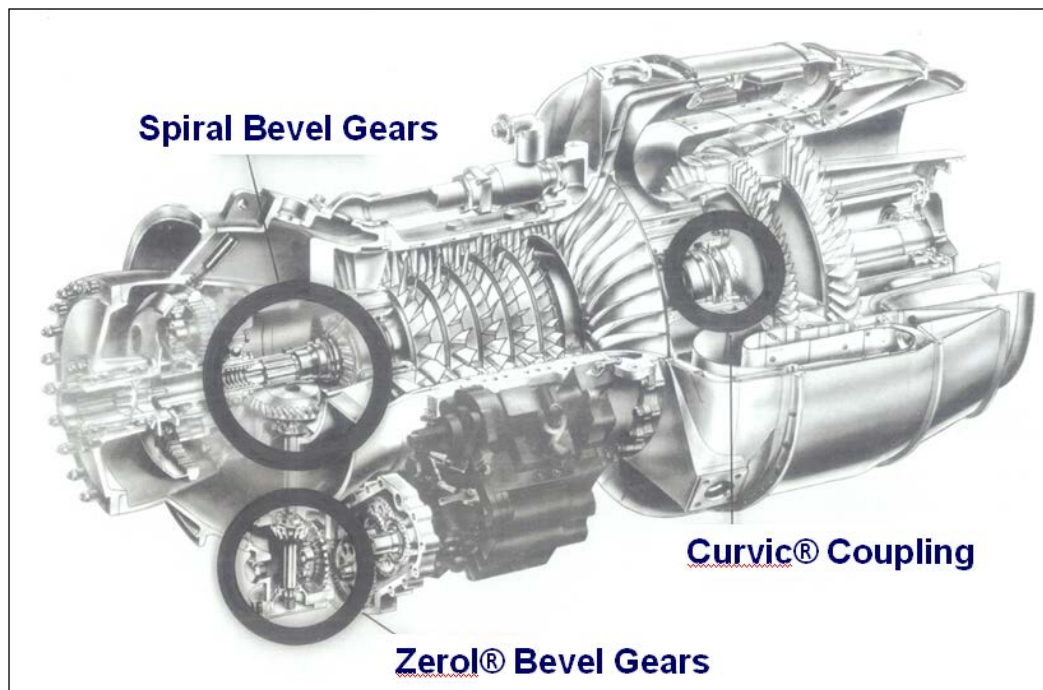

Figure 10 Jet engine with various bevel gear applications.



Figure 11 Helicopter with bevel gear actuated main and tail rotor (Source: Agusta Westland a FINMECCANICA Company).

around the circumference of the ring gear that take off redirect and power to auxiliary units such as a hydraulic pump and electrical generator. Also, energy for the tail rotor is branched off the main rotor ring gear by an additional pinion. At the tail rotor, another bevel gearset is utilized in order to redirect the rotation of the driveshaft running through the helicopter tail into the direction of the tail rotor axis.

Helicopter transmissions total about 10 bevel pinions and four ring gears — some of which have, for example, a hypoid offset in order to account for the asymmetric orientation of the tail rotor and its driveshaft. Because of space constraints and tight component packaging, almost all bevel gearsets are realized with shaft angles less than 90°. Helicopter transmissions are the most sophisticated and complex application for bevel gear systems. All aerospace power transmissions require ground flank surfaces and ground root fillets after heat treatment (Fig. 11).



Figure 12 Industrial gearboxes with different size.



Figure 13 Stern drive with two propellers (Dual-Prop) (Source: Konrad Marine).

Industrial Gearboxes

Industrial gearboxes are used in machines and equipment across many different industries. Redirection of motion is often required as the reduction of RPM between parallel axes. A typical industrial gearbox similar in appearance to what is used to actuate escalators, assembly line belts, lifting devices, and special machines is shown (Fig. 12, left). The efficiency of these gearboxes becomes increasingly important, as many of them have a 24/7 duty cycle. Industrial gearboxes are available with ring gear diameters ranging from below 50 mm up to diameters of 2,000 mm — due to their many different industrial applications. In Figure 12 (right) an angular transmission that drives a larger pump with a ring gear diameter of 1,000 mm is shown. Industrial gearboxes are hard-finished with skiving or grinding after their heat treatment.

Marine Transmissions

Stern drives (more commonly known as “outboard motors”) require two bevel gearsets between the motor and propeller. The high-power unit (Fig. 13) has two opposite hand propellers that rotate in opposite directions (twin-prop). The drivetrain of this unit is equipped with CONIFLEX straight bevel gears that are not hard-finished after heat treatment. Straight bevel gears — with optimized root fillet and a strength-increasing shot peening treatment — show for this particular application a higher root bending strength than spiral bevel gears.

Oceangoing vessels with a central, inboard motor utilize bevel gears to run the propeller shafts with changing angles along the hull to the ship’s stern. A power split onto two stern propellers — typical in many large ships — is handled by bevel gearsets with low shaft angles between 5° and 20°.

Thrusters (Fig. 14) have been used for many decades in ocean exploration platforms such as those used for pumping crude oil. On each of the four corners of such platforms a thruster with a propeller diameter of several meters is attached. The thrusters are used to maneuver the platform from shore to its geographical ocean location; once at the service location, they help maintain platform stability.

A thruster’s base construction is reminiscent of a gigantic stern drive. Today’s smaller-size thrusters are used to propel ships; they afford excellent maneuverability — which is why they are used in pilot boats and ice breakers, as well as in ships requiring nimble harbor maneuverability. Thrusters can also be attached to a vessel as a module; this eases or eliminates many of the existing restrictions in ship design that can be traced to the conventional “inboard” drivetrain and its location of the motors and propeller shafts.

Thrusters use two bevel gearsets (Fig. 14); depending on the application, the ring gear diameters can vary between 600 mm and 2,500 mm. Ninety percent of the bevel gears for the propulsion of ships are skived, while 10% are ground as a hard finishing operation.

Special Applications

Large bevel gears—not hard-finished after heat treatment—are found in equipment and machines for the surface mining of coal and ore (fracking), as well as for stone crushing and stone mills. In some cases these large bevel gears are assembled without any post-cutting heat treatment; in others, a flame or induction hardening is performed. Figure 15 shows an oil drilling platform; the rotation of a horizontally oriented, internal combustion engine is re-directed in the orientation of the drilling rod. This application requires the transmission of high torque with rotary impulses generated by the stone-drilling action and the elasticity of the long rod. The bevel gearset must have a high degree of toughness in order to avoid tooth fracture due to, for example, a locking drill. To fulfill the requirements above, the bevel gears are surface-hardened and, because there is a ring gear diameter of about 1,500 mm in this unit, the bevel gears are hard-finished by skiving, as grinding is usually only recommended for diameters of up to 800 mm. **PTE**

Sources. *The reproduction of photographs in this chapter that were not available as press material has been granted to the author and publisher by the owner by written permission. Photo material of the following companies has been used: Daimler AG; ZF Friedrichshafen AG; General Motors Corporation; Chrysler Group LLC; Liebherr; AgustaWestland (a FINMECCANICA Company); MAAG Pumpen AG; Konrad Marine; and Rolls Royce Marine.*



Figure 14 Thruster for marine applications (Source: Rolls Royce Marine).

For Related Articles Search

bevel gears

at www.powertransmission.com

Dr. Hermann J. Stadtfeld received in 1978 his B.S. and in 1982 his M.S. in mechanical engineering at the Technical University in Aachen, Germany; upon receiving his Doctorate, he remained as a research scientist at the University's Machine Tool Laboratory. In 1987, he accepted the position of head of engineering and R&D of the Bevel Gear Machine Tool Division of Oerlikon Buehler AG in Zurich and, in 1992, returned to academia as visiting professor at the Rochester Institute of Technology. Dr. Stadtfeld returned to the commercial workplace in 1994—joining The Gleason Works—also in Rochester—first as director of R&D, and, in 1996, as vice president R&D. During a three-year hiatus (2002–2005) from Gleason, he established a gear research company in Germany while simultaneously accepting a professorship to teach gear technology courses at the University of Ilmenau. Stadtfeld subsequently returned to the Gleason Corporation in 2005, where he currently holds the position of vice president, bevel gear technology and R&D. A prolific author (and frequent contributor to *Gear Technology*), Dr. Stadtfeld has published more than 200 technical papers and 10 books on bevel gear technology; he also controls more than 50 international patents on gear design, gear process, tools and machinery.



Figure 15 Oil drilling tower.

The Latest Design Technologies For Gear Devices with Great Transmission Ratios

Shuting Li

Four types of gear devices with great transmission ratios (simply called great ratio gears or GRGs) are discussed in this paper. They are strain wave gearing devices (SWGs), trochoidal gear reducers (TGRs), hypocyclic gear reducers (HGRs) and James Ferguson-type planetary drives (JFDs). The structures, advantages and basic performances of these four devices are compared. The latest design and strength analysis methods are also introduced. To conclude, the future tendencies of GRGs are predicted.

Introduction

In the latter period of the 20th century, factory automation was developed very rapidly in order to satisfy the requirements of mass production and reduce product cost. Industrial robots were successfully developed—mainly in Japan, Germany and Switzerland—for the express purpose of factory automation. Then GRGs—such as the SWGs and the TGRs—found applications in industry as robot joints. This was the beginning of GRGs being widely used in industry. Today, countless SWGs and TGRs are made every day, and they are used not only in robots, but also in many other high-performance machines such as semiconductor devices, aircraft and space-exploring machines, as well as critical power transmission devices.

Yet, after much R&D in making high-performance SWGs and TGRs a reality, design and strength calculation problems of the GRG remain.

This paper introduces the latest results of an extended period of comprehensive research on the design and strength calculation methods of the SWGs, TGRs, HGRs and JFDs. First, the structures, advantages and basic performance of the four GRGs are compared. Next, design and strength analysis methods developed for these four GRGs are introduced. And last, future tendencies are predicted for GRGs.

Structures, Advantages and Basic Performances of the GRGs

An SWG is also known as a harmonic drive device; it was invented by Musser (Ref.1) in 1957. Figure 1 is a structural example of a cup-typed SWG. As shown there, the SWG mainly consists of a thin-rimmed flex-spline (FS) spur gear; an internal spur gear, also known as a circular spline (CS); an elliptical-shaped cam, or wave generator (WG); and a flexible ball bearing (FB) that can be deformed freely by the WG.

Transmission ratio of the SWG—when the CS is fixed and the FS is

used as output—can be calculated by (Z_1/N) . Here, Z_1 is the tooth number of the FS; N is lobes of the WG. Usually, the WG assumes the shape of an ellipsoid; therefore $N=2$ at this time. If Z_1 is substantial, great transmission ratio can be available. Now, the SWG with transmission ratios among 30 and 200 are made as mass production products by makers.

Beyond the great ratio, benefits such as light weight, small size, very slight backlash and extremely high transmission accuracy are other advantages of this device. Also, the SWG can be made

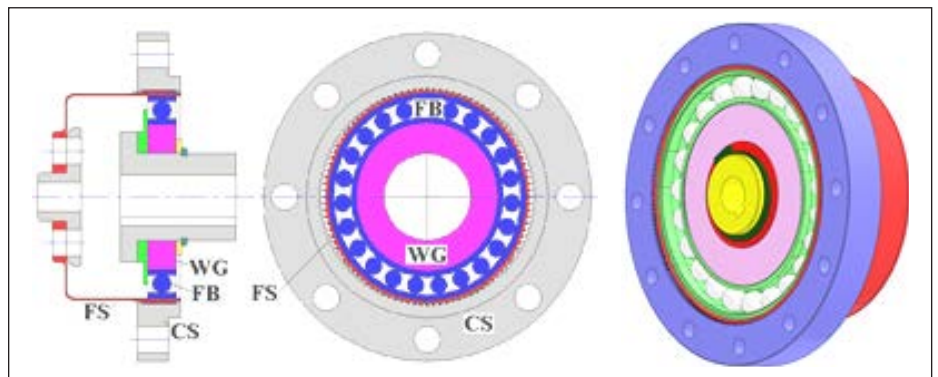

Figure 1 A structural example of the cup-type of SWG.

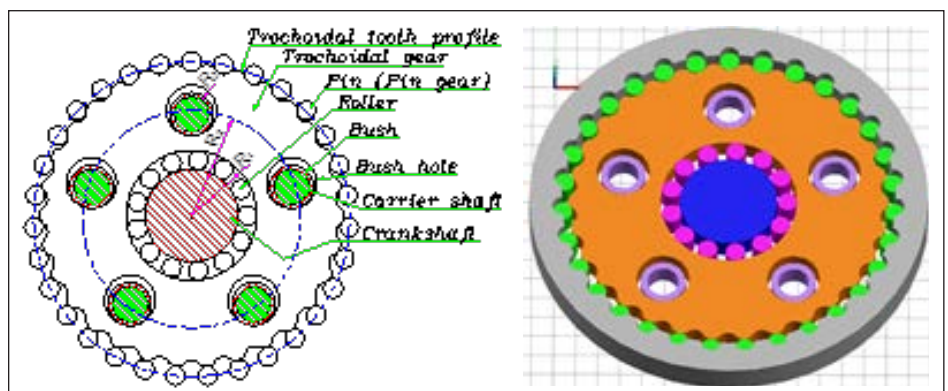

Figure 2 A structural example of the TGR.

very small—like a micro-machine. With these advantages, the SWG has found wide applications in industry, as well as in humanoid robots in recent years.

Trochoidal gear reducer (TGR). TGR is also known as a cycloidal gear reducer. It was invented by Lorenz Braren, a German engineer, in 1927 (Fig. 2). As shown there, an external spur gear with trochoidal profile—AKA *trochoidal gear*—is used. Many pins are used as teeth of an internal—or *pin*—gear. Like the SWG, an eccentric cam—or *crankshaft*—is used to drive the trochoidal gear to engage with the pin gear. Transmission ratio of the TGR can be calculated by $Z_2/(Z_2-Z_1)$ when the pin gear is used as output. Here, Z_1 and Z_2 are tooth numbers of the external and internal gears, respectively. Usually, $(Z_2-Z_1)=1$ and then the transmission ratio becomes Z_2 . So, if Z_2 is made very large, extreme transmission ratio can be made available.

In addition to great transmission ratio, the TGR is also characterized by great torsional rigidity, high load-carrying and overloading capacities. This

is because the number of contact teeth can be increased when larger torque occurs. The TGR also has high efficiency and strong tooth root strength because of the trochoidal profile. It is well known that only rolling contact (no sliding) exists between the contact teeth. But now the TGR can be made with very small backlash, lost motion and transmission errors.

Hypocycloidal gear reducer (HGR). HGR is a planetary drive with small tooth number difference. Figure 3 is a structural example of the HGR. In Figure 3 it is seen that the kinematics of the HGR is exactly the same as for the TGR, with only difference being the tooth profile curves. When involute curves are used as tooth profiles of the external and internal gears, the TGR becomes the HGR. The HGR can be made simpler than the TRG. This is because it is simpler to make the involute teeth than to make the trochoidal teeth. Transmission ratio of the HGR can be calculated in the same way as the TGR. The HGR has lower load-carrying capacity than the TGR. This is because the number of contact teeth of the HGR is less than

that of the TGR due to use of the involute profile. Of course, the torsional rigidity and overloading ability of the HGR are also lower than the TGR; perhaps this is the main reason why the HGR cannot be used widely in industry as is the TGR. It is presently a research subject of the author's as to how to increase the number of contact teeth of the HGR by way of a suitable involute tooth profile.

James Ferguson-type planetary drive (JFD). A James Ferguson mechanism (Ref. 2) is one in which one gear engages with the other two or three gears on the same tooth surface. This mechanism was also used in planetary drives for achieving great transmission ratio and compact size design (Ref. 3). The planetary drive that uses the James Ferguson mechanism is called the James Ferguson-type planetary drive (JFD) in this context (Fig. 4; Ref. 3). In Figure 4, Z_1 and Z_2 are tooth numbers of the sun gear and the planetary gear, respectively; Z_3 and Z_4 are tooth numbers of two internal gears. As shown in Figure 4, the planetary gear Z_2 engages with two internal gears (Z_3 and Z_4) on the same tooth surface. This is the main difference between a typical planetary drive and a JFD. In most cases a transmission ratio of a planetary drive cannot exceed 14; but the transmission ratio of the JFD can be greater than 100. The transmission ratio of the JFD can be calculated by $(1+Z_3/Z_1) / (1-Z_3/Z_4)$. Here, Z_4 is greater than Z_3 and (Z_4-Z_3) is equal to the number of the planetary gears used in the JFD.

Tooth interference must be checked twice, since two internal gears are used in the JFD. In order to avoid tooth interference, Z_1 , Z_2 , Z_3 and Z_4 cannot be given freely as desired. So, too, transmission ratio of the JFD cannot be obtained freely as desired. This is the first disadvantage of the JFD. The second disadvantage of the JFD is lower load-carrying capacity. It shall be introduced later that tooth side-heavier contact occurred in the JFD due to a face width discrepancy between the planetary gears and internal gears. It, too, is now a continuing research project of the author on how to reduce the tooth side-heavier contact through considering a new structure, or by performing tooth lead modifications.

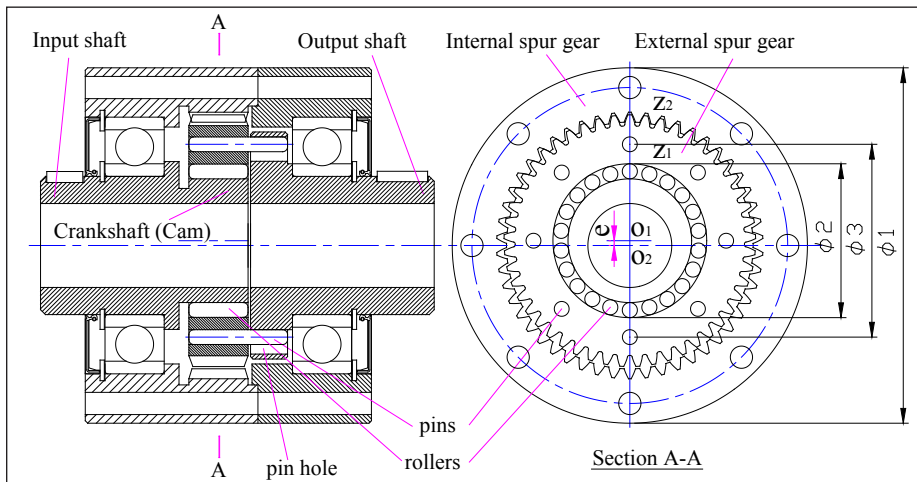

Figure 3 A structural example of the HGR.

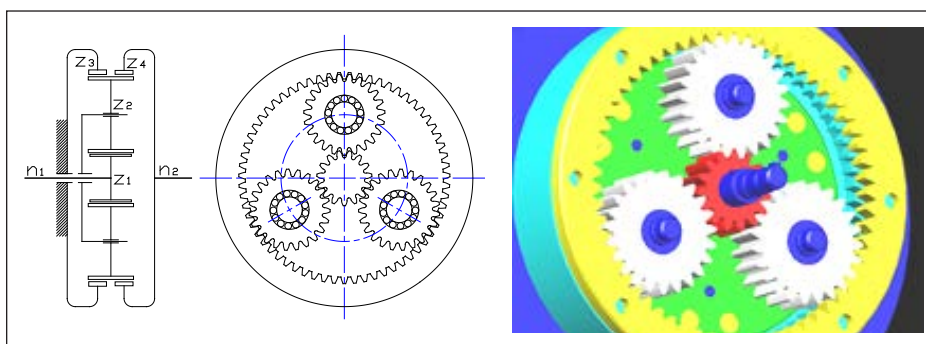

Figure 4 A structural example of the JFD.

The Latest Design and Strength Analysis Technologies for GRG

Design and strength analysis methods of the four GRGs differ from those of usual gears. For the latter, tooth contact and bending strength calculations are the main items in strength analyses, while for the GRG, tooth strength as well as bearing strength must be analyzed simultaneously. This is because contact fatigue failures of the bearings in the GRGs are also the *main* failures. In order to solve strength calculation problems of the GRG, special finite element methods have been developed to do contact analyses of these devices separately, based on long-term study by the author. Loads distributed on teeth, bearing balls and rollers are analyzed — initially through contact analysis with the developed FEM. Then tooth and bearing strength are evaluated using FEM and Hertz's formula once the loads on teeth, bearing balls and rollers become known. These main procedures are introduced in the following sections.

Strain wave gearing device (SWG).

In the mass production products of the SWG, three kinds of curves are now used as tooth profiles; i.e. — straight line, involute, and arc profiles, respectively. Tooth profile design of the SWG is a difficult thing for designers. This is because tooth profile design of the SWG must take the cam shape of the WG into account since cam shape has direct effects on tooth engagement. It requires very sophisticated technology in order to be able to design a suitable tooth

profile with high performances for the SWG. Special software has been developed to do tooth profile design and geometric dimension calculations of the SWG, based on more than 20 years' experience of the author with the SWG. Figure 5 is an example of applications of the developed software. This software was developed to run in the *AutoCAD* environment using *AutoCAD* VBA language. The straight line, involute, and arc curves are programmed in the software. When the gearing parameters are input in the software, tooth profile

design and geometric dimension calculations can be conducted automatically with the help of this software. The 2D drawings (Fig.5 (a)) can be drawn automatically on the drawing template of *AutoCAD* in a few seconds. 3D drawings (Fig.1(b)) can also be executed via 3D commands of the *AutoCAD* or *SolidWorks* software based on the 2D drawings.

Strength calculations of the SWG are another difficult hurdle for designers. This is because there is not yet available a simple method to do strength calcula-

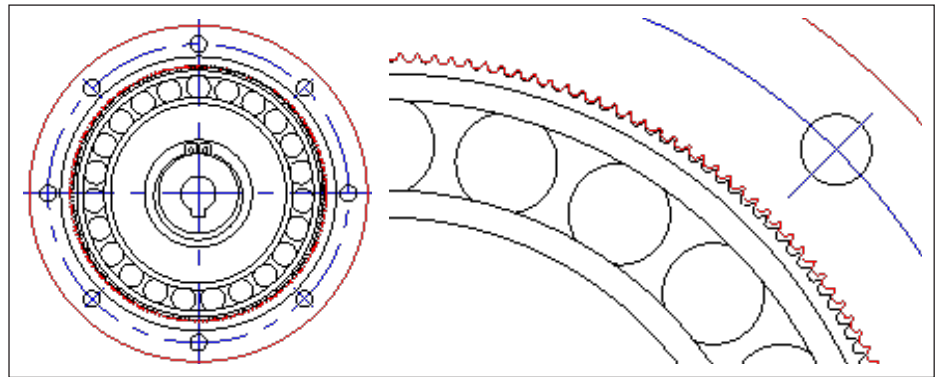

Figure 5 Geometric calculations and automatic drawing of the SWG.

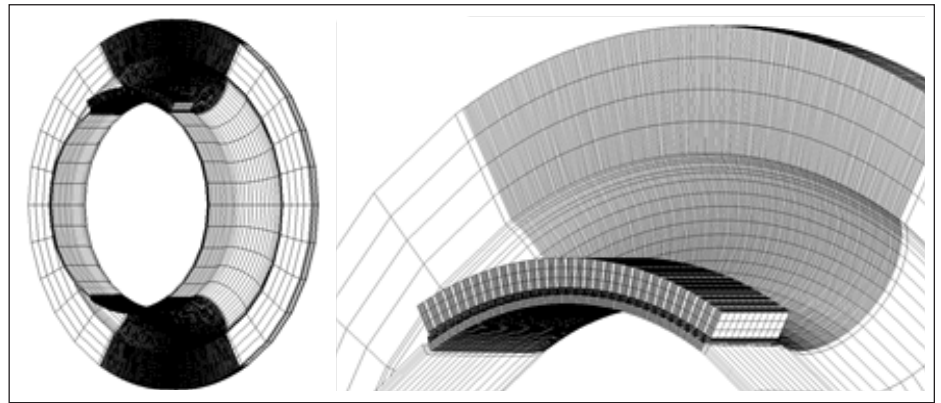

Figure 6 3D FEM model used for contact analysis of SWG.

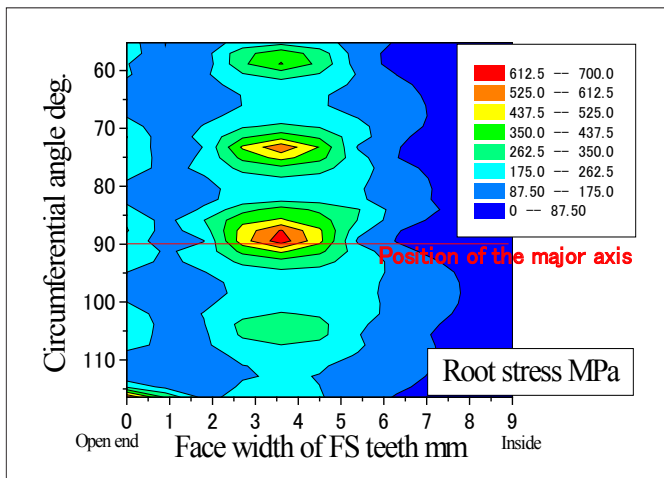

Figure 7 Tooth root stress distribution.

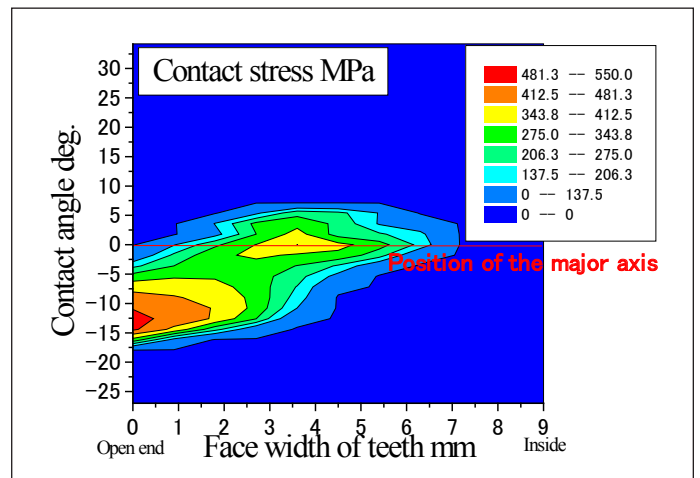

Figure 8 Tooth contact stress distribution.

tions of the SWG. To solve this problem the author in 1987 began seeking a suitable method for strength calculations of the SWG. A unique FEM for the SWG was eventually developed after a very long period of research. Today it is possible to calculate the following strength items of the SWG with the developed FEM software:

1. Contact strength of the contact teeth
2. Bending strength of FS tooth roots
3. Bending strength of FS structure (tube and diaphragm)
4. Contact strength of the FB.

(Except for these four items, buckling strength calculation of FS tube must also be included in the design procedures.)

Figure 6 is a 3D FEM model used for contact analysis of a silk-hat-type of the SWG (Ref. 4). Figure 7 is the root bending stresses of the FS teeth calculated by the developed FEM software. Figure

8 is the calculated maximum contact stresses on FS tooth surfaces. From Figure 7 it is found that the root bending stresses of the FS teeth are affected by the ball positions of the FB. Figure 8 indicates that the tooth contact pattern of the SWG is much more complex than that of usual gears.

Trochoidal gear reducer (TGR). Design software has been developed also for the TGR in an *AutoCAD* surrounding like the SWG (Fig. 9). With this software TGR can be designed very quickly and automatically. The 2D drawings of the designed TGR can be drawn automatically on the drawing template of *AutoCAD* (Fig. 2 (a)) and the 3D drawing can be made as shown (Fig. 2 (b)) using 3D commands of *AutoCAD* based on the 2D drawings.

Yet another difficulty is for designers to perform strength calculations of the TGR. This is because it is still an

unsolved problem to do three-dimensional contact analyses of the loads on teeth, bushes and rollers of the TGR (Fig. 2(a)), although many efforts have been made to solve this problem. It was started in 1994 by the author to develop a method and software that can do strength analyses of the TGR using 2D FEM. Now it is indeed possible to calculate the contact loads and stresses on teeth, bushes and rollers of the TGR with the developed 2D FEM software.

Figure 10 is the 2D FEM model used for contact analysis of the TGR with the parameters indicated in Figure 9. Figures 11-13 are calculated contact loads and stresses on teeth, bushes and rollers when a torque load is applied. Numbers of the teeth, bushes and rollers used in Figures 11-13 are also indicated in Figure 10. With the calculated contact stresses, the contact strength of the teeth, bushes and rollers can be

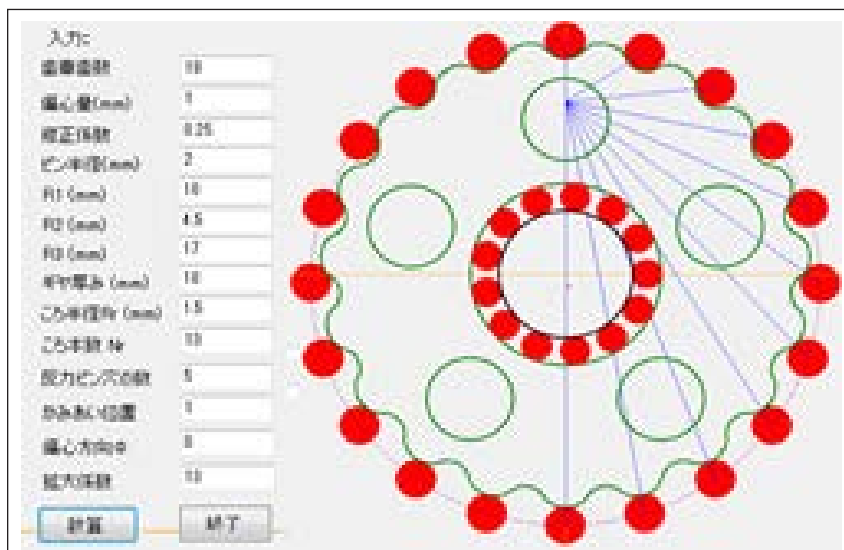

Figure 9 Automatic design program for TGR.

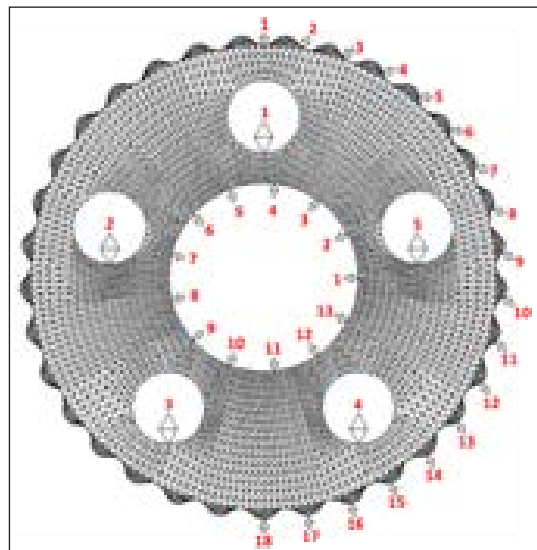

Figure 10 FEM model for contact analysis.

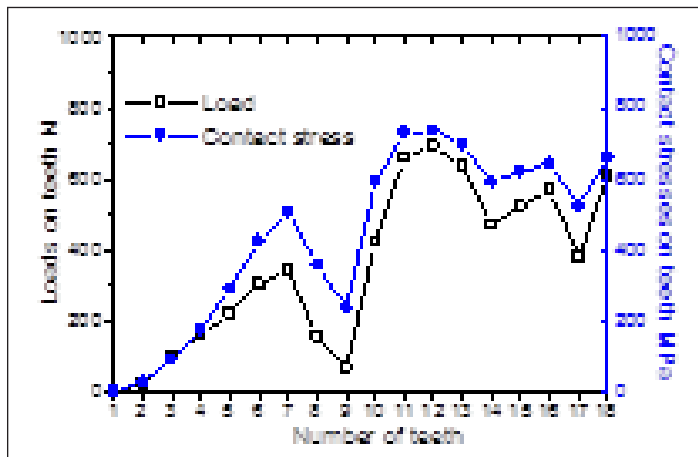

Figure 11 Loads and stresses on teeth.

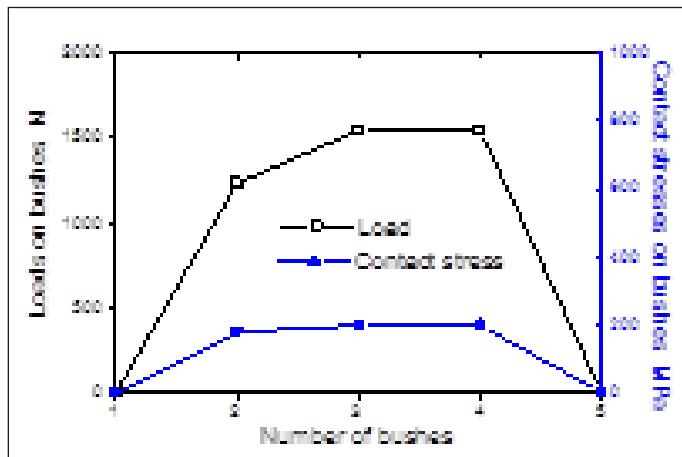

Figure 12 Loads and stresses on bushes.

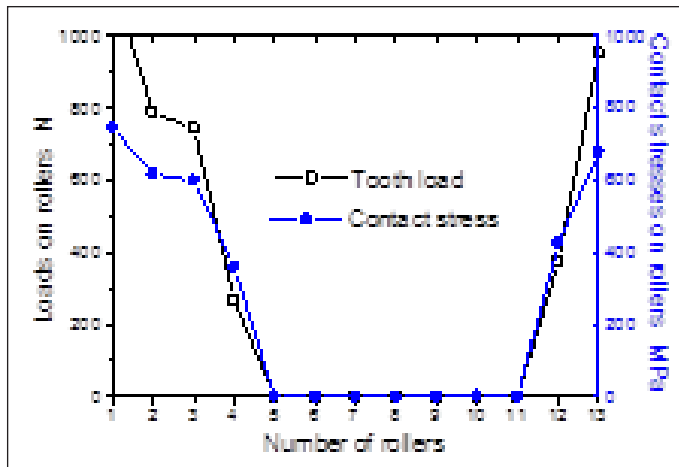

Figure 13 Loads and stresses on rollers.

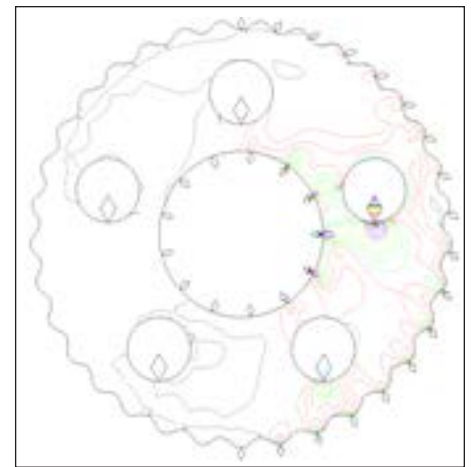

Figure 14 Von Mises stresses.

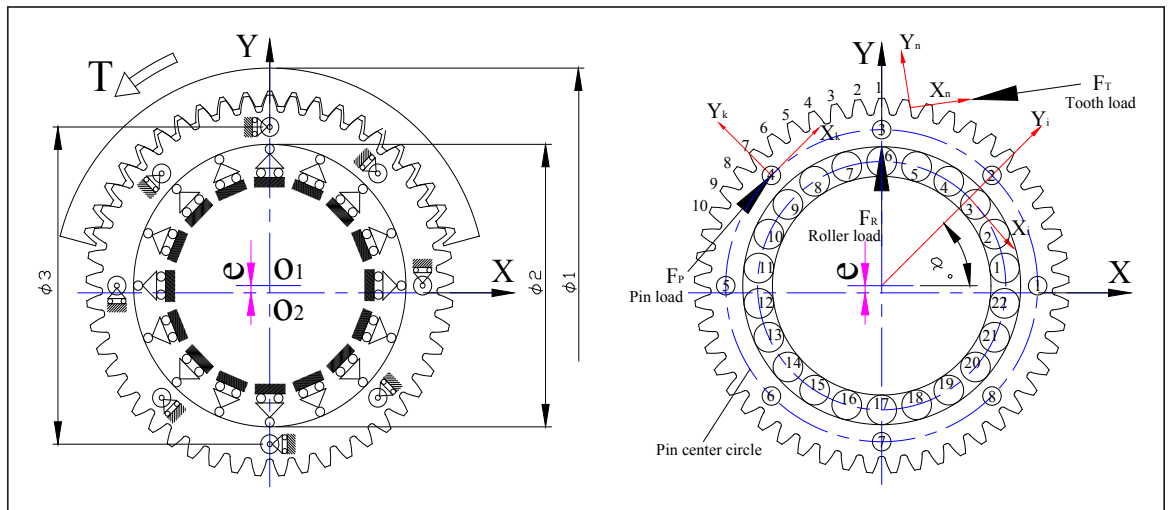

Figure 15 Mechanics model used for contact analysis of the HGR.

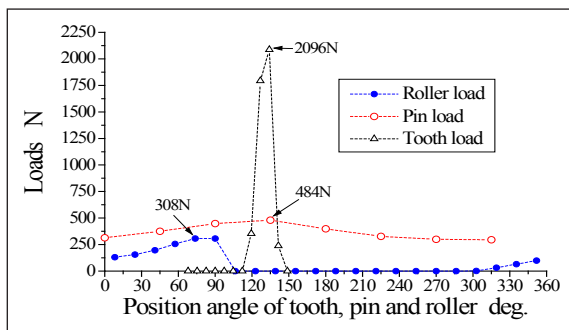

Figure 16 Loads on rollers, pins and teeth.

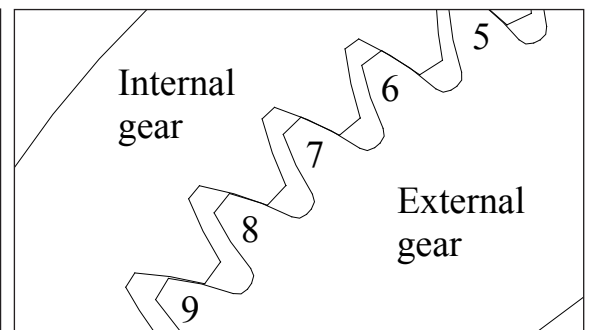

Figure 17 Enlarged view of engaged teeth.

evaluated two-dimensionally. Figure 14 is the calculated Von Mises stresses on the trochoidal gear; it can be used to evaluate the bending strength of the trochoidal gear—but it is rarely used for the TGR.

Hypocyclic gear reducer (HGR). Geometric design and strength calculation of the HGR also differ from usual gear devices. In order to be able to conduct strength calculations of the HGR, a special method used for contact analy-

sis of the HGR has been developed using FEM (Ref.5). Figure 15 is the mechanics model used for contact analysis of the HGR (Fig.3). With this model and the developed FEM, loads on contact teeth, pins and center rollers were analyzed (Ref.5) and are given in Figure 16, where it is found that only four pairs of teeth (tooth pairs 5, 6, 7 and 8 as shown in Figs. 17 and 15) are in contact. This means that the contact tooth number of the HGR is much less than that of the

TGR. As shown in Figure 11 there are 17 teeth in contact—from No. 2 to 18—for the TGR. It also means that tooth profile has a significant effect on contact tooth number. Though the HGR can be made easily because of using the involute profile, since contact teeth are much less than that of the TGR, the load-carrying capacity of the HGR becomes much lower than that of the TGR. This may be why the HGR cannot find wider applications in industry. For now, it is a research sub-

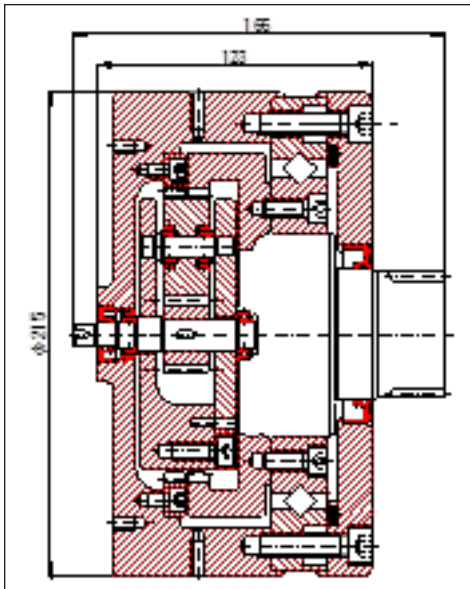

Figure 18 An example of JFD.

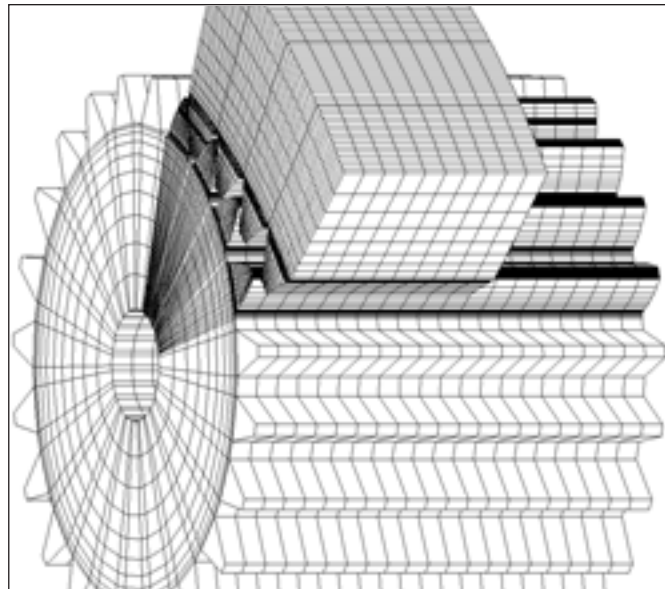

Figure 19 FEM model (different face widths).

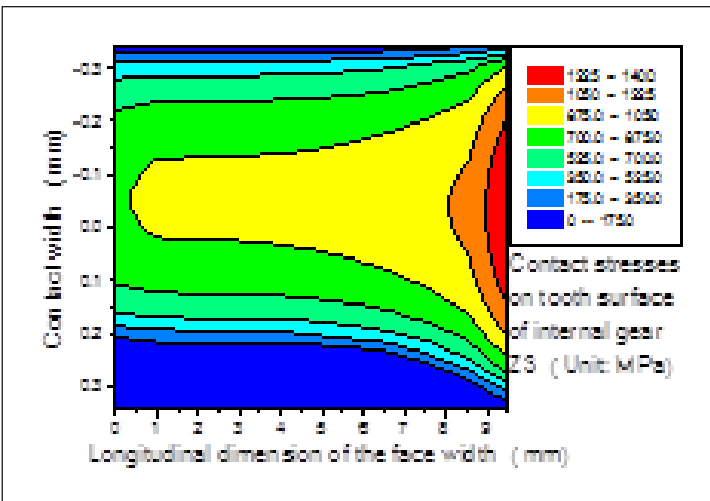

Figure 20 Tooth contact stresses on Z_3 .

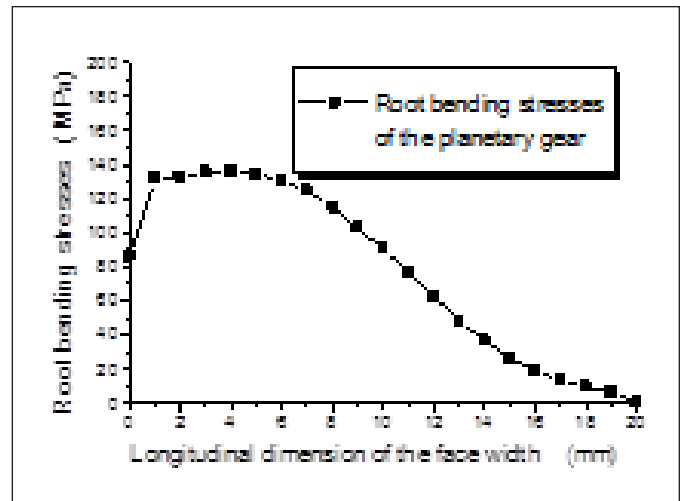

Figure 21 Tooth root stress of Z_2 .

ject for the author on how to increase the contact tooth number of the HGR; a new tooth profile is under study.

James Ferguson-type planetary drive (JFD). One of structural differences between the JFD and a usual planetary drive is the face width difference of the contact teeth between the planetary gears and the internal gears. In the case of JFD, face width of the planetary gears is about twice that of the internal gears (Fig. 4). This means that only half-a-length of the face width of the planetary gears is used to contact with the entire length of the face width of the internal gears (Z_3 or Z_4). This tooth contact on different face widths makes it difficult to do bending and contact strength calculations of the contact teeth using the methods

available for usual gears. So, a 3D FEM is developed to do loaded tooth contact analysis of the contact teeth with different face widths.

Figure 18 is a structural example of the JFD designed by the author based on the basic structure shown in Figure 4. In Figure 18, Z_1 , Z_2 , Z_3 and Z_4 are tooth numbers of the sun gear, planetary gear, and internal gears (left-side and right-side), as indicated in Figure 4. Figure 19 is an FEM model used for loaded tooth contact analysis of the planetary gear Z_2 with the internal gear Z_3 . As we see in Figure 19, the internal gear teeth are in contact with the right half-length of the planetary gear teeth.

Figure 20 shows the calculated contact stresses distributed on the tooth surface of the internal gear Z_3 . Figure 21

is the calculated root bending stresses of the planetary gear Z_2 distributed along the longitude. From Figure 20 it is determined that contact stresses are not uniformly distributed along the longitude of the internal gear teeth; i.e. — the side-heavier contact occurred on the right side of the contact teeth. In Figure 21 it is also seen that tooth root bending stresses are not uniformly distributed along the longitude of the planetary gear tooth; the left half-length of the planetary gear tooth has larger root stress distribution than the right half-length of the teeth. Although the right half-length of the face width is not used to contact with the internal gear teeth, the right half-length of the tooth also has smaller root stresses. Figures 20 and 21 indicate that the contact and

bending stresses of a pair of gears with different face widths are different from that of a pair of normal use gears with equal face widths. It is now another research project for the author on how to reduce the side-heavier contact of a pair of gears with different face widths through lead modification on the internal gear Z_3 .

Future Tendencies

A common gearing theory. In the future it will become necessary to build a common gearing theory for the SWGs, TGRs and HGRs, since there is a common point existing in all three devices that use eccentric movement to realize the great transmission ratios, as well as having very similar tooth engagement movements.

To date, gearing principles for a pair of conventional gears without eccentric movements (for example: a pair of spur gears or helical gears) have been well studied, but the same cannot be said for the gearing principles of the GRG with eccentric movements. The gearing theories of the SWG and TGR were built separately, while the gearing theory of the HGR has yet to be built. Plainly, it remains a difficult task to design a new type of tooth profile for the HGR. A most worthwhile future goal is to build a common gearing theory for these three GRGs. It may yet be proven that basic performances and load-carrying capacities of the three GRGs can be greatly improved when a new type of tooth profile is developed with the help of common gearing theory.

Lightweight, small size and high-torque transmission. In the last century, much effort was exerted in making the GRG as lightweight, small-sized and high in load-carrying capacity as possible, primarily because these items were required by users as product specifications and these items reflect the competitiveness of the makers' products. In order to create lightweight, small-size, high-torque transmission, many studies were conducted on gear design, materials, machining accuracy and heat

treatment methods. No doubt, these studies markedly improved performance of the GRG and also increased strength and competitiveness of the makers' products. Some makers were very successful in their business and able to compete in very large markets through these efforts. Per the industry experiences of the author, lightweight, small-size and high-torque transmission design are also important for the GRG in the future, as market demand will ensure their importance for quite a long time.

High transmission ratios. Prior to 2000, it was well-accepted to use high-speed, small-size motors in combination with the GRG to transmit great torque in industry robots and other machines. This idea is also successful in humanoid robots (for an example, Honda's ASIMO), NASA's Mars Rover and many other new machines. Now this idea is accepted by many engineers as a general design thought and used widely in new machine development. A familiar nickname — "Gearhead" — is also given to this idea by engineers, and is used very often in factories. Today's "Gearheads" often have transmission ratios among 30 – 200. In the future, much higher transmission ratios — among 200 – 400, for example — may well be needed in the marketplace. This would create new business opportunities in the future to design and make the much higher transmission ratio "Gearheads."

High performances. Also prior to 2000 much effort was expended in improving the performance of the GRG in order to satisfy market requirements. Today it is possible to make very high-performance GRGs with low transmission errors, low vibration, low noise, high transmission efficiency, and high strength with the help of gear technology advances in design, FEM analysis, materials, heat treatment and machining accuracy. Per the author's industry experience, it can be predicted that even much higher GRG performance will be pursued by users in the future.



Conclusions

- Structures, advantages and basic performance of four types of great transmission ratio gear devices — the strain wave gearing device; trochoidal gear reducer; hypocyclic gear reducer; and James Ferguson-type of planetary drive are introduced and compared.
- The latest design and strength analysis methods of the four great transmission ratio gear devices are introduced.
- Future tendencies of the great transmission ratio gear devices are predicted, based upon the extensive industry experience of the author with great ratio gear devices. **PTE**

References

1. Musser, C. W. "Breakthrough in Mechanical Drive Design — The Harmonic Drive," *Machine Design*, April 14, pp. 160-173, 1960.
2. Ferguson, James. *The Description and Use of a New Machine, Called the Mechanical Paradox*; Invented by James Ferguson, London, 1764.
3. Takashi, N. *Involute Profile Shifted Gears* (in Japanese), JSME press, 1994.
4. (4) Li, S. "A Challenge to Design of a New Harmonic Drive Device," *Applied Mechanics and Materials*, Vol. 86, 43-46, 2011.
5. Li, S. "Contact Problem and Numeric Method of a Planetary Drive with Small Teeth Number Difference," *Mechanism and Machine Theory*, Vol.43, Issue 9, 1065-1086, 2008.

Shuting Li is an associate professor at Shimane University in Japan, and an active member of the Administration Committee of the JSME Machine Design & Tribology Division. He graduated in 1986 from the Department of Aircraft Manufacturing at the Northwestern Polytechnical University in China, receiving his Ph.D. from Yamaguchi University (Japan) in 1998. Li has 28 years' experience in gear research — including 13 years of industry experience. He has authored more than 50 papers on gear research and since 2000 has also served as reviewer for many international journals, including ASME Trans. J. Mech. Des., and Mech. Mach. Theory.



HANNOVER MESSE. Are you **ready** for

the **4th Industrial Revolution?**

13 – 17 April 2015
Hannover • Germany

hannovermesse.com

Find out about
the factory of the
future – and all
the latest trends.

Partner Country
India 2015



Deutsche Messe

Get new technology first



Finite Element Evaluation of Bearing Instrumentation Method

J. Austin, Dr. David Talbot, Dr. Donald Houser and Dr. Sandeep M. Vijayakar

This paper presents an evaluation of measurements being taken on a 750 kW wind turbine gearbox being tested by the National Renewable Energy Laboratory (NREL). High-speed stage gears and bearings have been identified as critical components of the gearbox; during gearbox testing, these components were instrumented and tests were developed to evaluate loads on high-speed tapered roller bearings (TRBs). In this paper an advanced finite element-based contact modeling procedure has been applied to model the high-speed stage with the bearings fully modeled in order to evaluate strain levels. A major conclusion is that the strains of the slotted grooves are at such a level that they have acceptable signal-to-noise levels. This was verified by the results of the initial experiments presented here.

Introduction

Motivation and gearbox configuration. The National Renewable Energy Laboratory (NREL) has made a commitment to address wind turbine gearbox reliability as part of its research agenda. A gearbox reliability collaborative (GRC) was developed to address major gearbox issues with the goal of increasing the overall reliability of wind turbines. Many gearbox problems may be a result of poor communication and feedback during the design, operation, and maintenance of turbines (Ref.1). The GRC is aimed at uniting these equally critical elements of the design process and encouraging collaboration and information sharing. A 750 kW turbine design, representative of many turbines currently in service, was selected by a committee of experts and gearbox consultants hired by NREL under the GRC.

The majority of observed failures appears to initiate at bearing locations, and are not a result of gear failures or gear-tooth design deficiencies. The failures appear to initiate at bearing locations and then propagate into other components of the gearbox. During the first iteration of testing there were a number of component failures seen in the gearbox, many of which were attributed to lubricant starvation. Components damaged in this gearbox included the high-speed gearset, sun spline, and planet bearings (Ref.2). The gearbox underwent a redesign and so began a new iteration of testing.

The GRC gearbox is shown in Figure 1; its design is a speed increaser that includes a planetary stage followed by two parallel shaft stages. The gearbox has a power capacity of 750 kW, with an

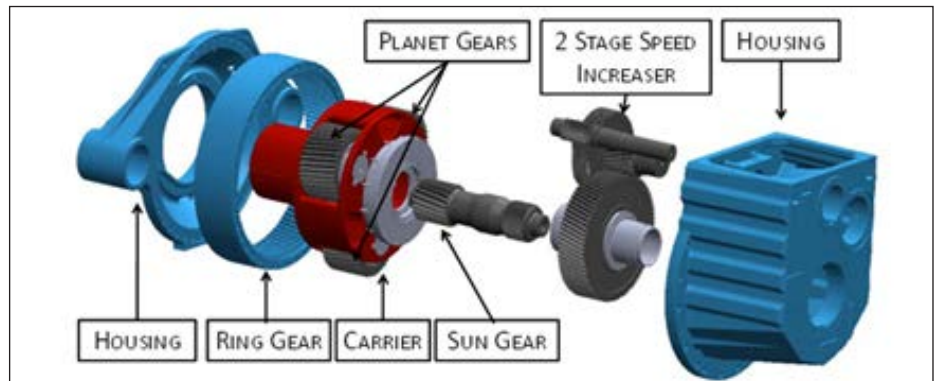

Figure 1 Exploded view of example gearbox (Ref. 3).

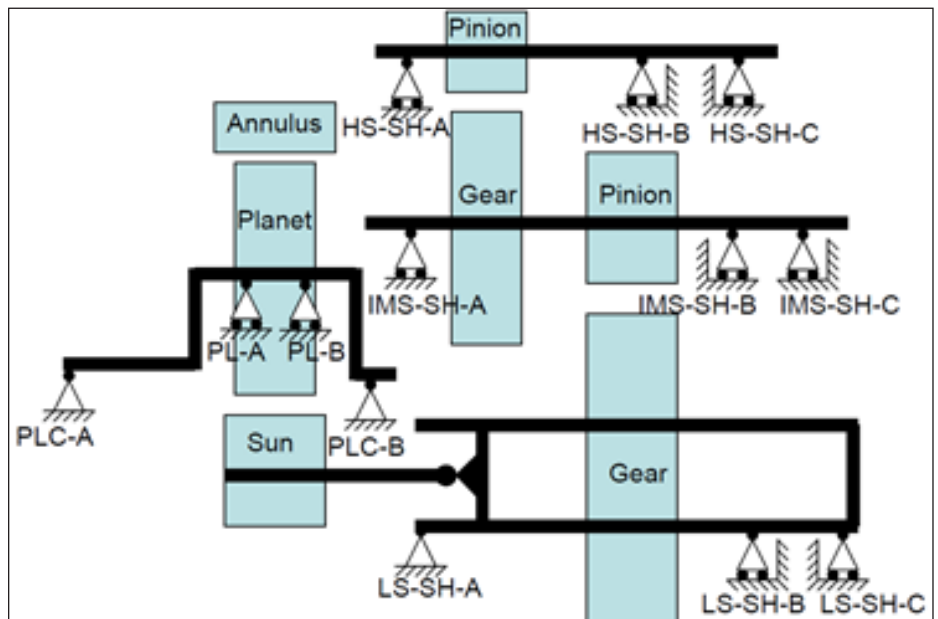

Figure 2 Gearbox bearing locations and nomenclature (Ref. 3).

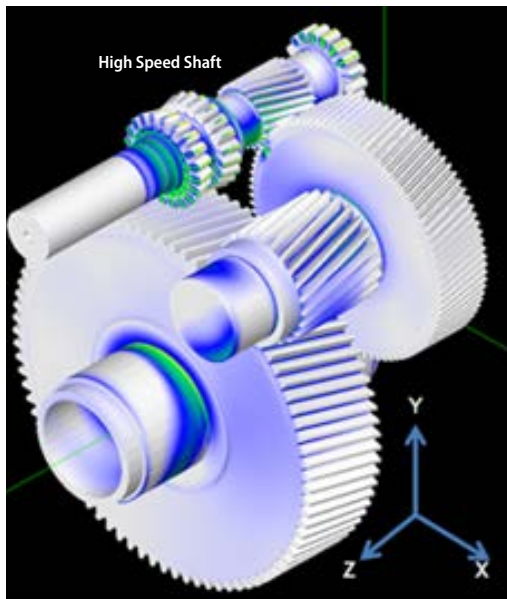

Figure 3 *Transmission3D* model showing high-speed, intermediate speed, and low-speed shaft stages.

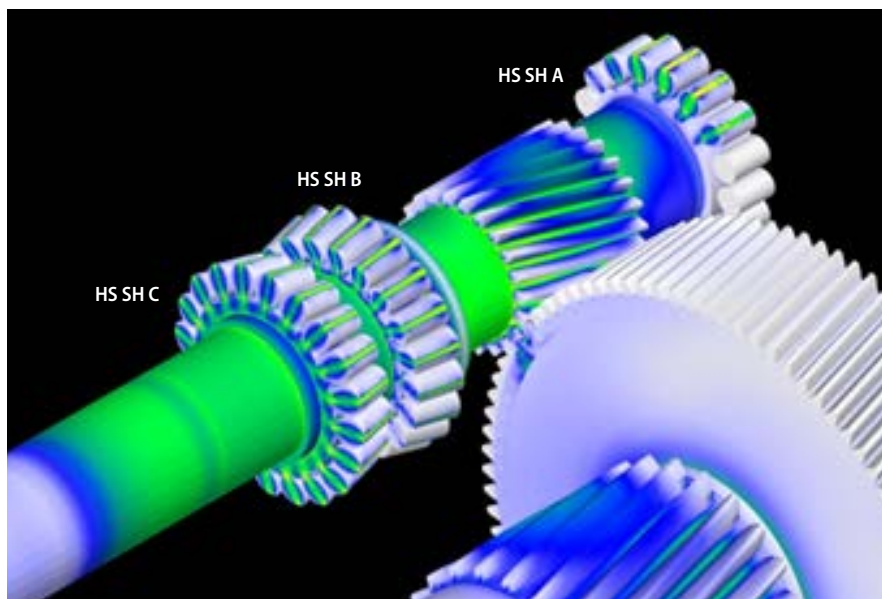

Figure 4 *Transmission3D* high-speed shaft stage with bearings fully modeled.

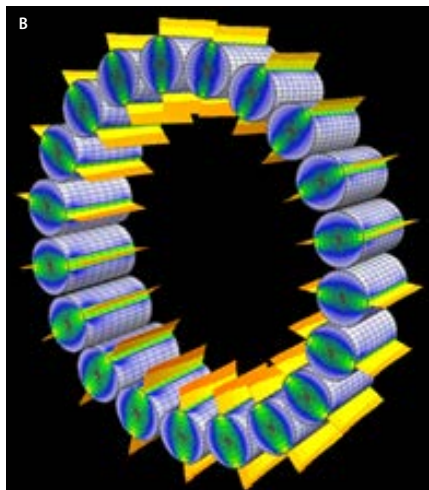
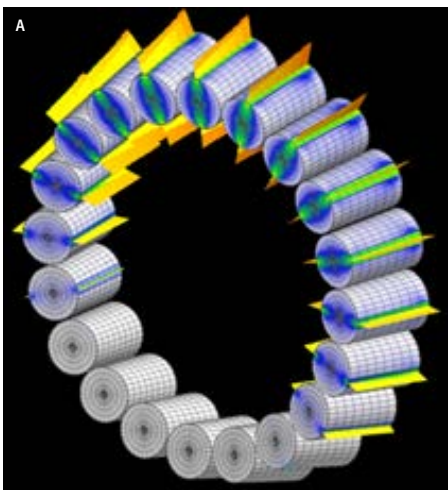

Figure 5 A) HS SH B and B) HS SH C roller contact pressure distribution.

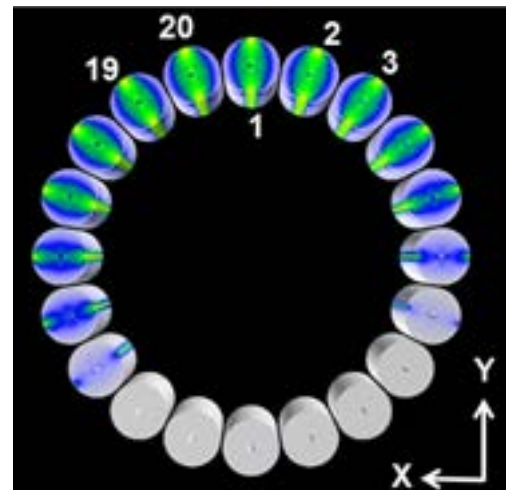

Figure 6 HS SH B TRB rollers with numbering convention.

overall speed increase ratio of 1:81,491. The nominal input speed is 22 rpm, with the output speed at 1,800 rpm. A 323 kN-m input torque is required on the rotor blades to operate the generator at full-rated power.

The following nomenclature will be used throughout the rest of this document when referencing internal components of the gearbox:

“*Upwind components*” are those located on the entrance side of the stage before power has passed through the gear.

These may also be termed “*rotor side*,” as they are located closer to the rotor.

“*Downwind components*” are those located on the aft end of the shaft.

Parallel shaft stages are comprised of three separate shafts—each supported

by three bearings. The bearing configuration of each shaft consists of a cylindrical roller bearing on the upwind portion of the shaft: (LS-SH-A, IMS-SH-A, HS-SH-A); and a pair of tapered roller bearings (TRBs): (LS-SH-B, IMS-SH-B, HS-SH-B, LS-SH-C, IMS-SH-C, HS-SH-C) on the downwind portion of the shaft. Bearing locations and naming convention are shown (Fig. 2). The subject of this paper will be the high-speed pinion shaft bearings (HS-SH-B, HS-SH-C) that support the upper shaft of Figure 2.

Transmission3D and Calyx. *Transmission3D* is a linear, finite element (FE) contact analysis program developed by Advanced Numerical Solutions LLC (Ref. 4), specifically designed for the analysis of multi-mesh-gear

drivetrains. The program empowers the user to model the housing, bearings, shafts, planet carrier, and gears as deformable bodies. Gear microgeometries can be included, as well as assembly and manufacturing errors. Bearings are generated similar to gears, and can include crowning on the rollers and races, as well as clearance and preload.

The greatest benefit of *Transmission3D* is in the contact algorithm. Gear, bearing, and spline stresses are localized and influenced by microgeometries on the micron scale. *Transmission3D* uses a unique contact analysis solver—*Calyx*—that utilizes a hybrid algorithm of finite elements to predict far field displacements, and an elastic half-space model to predict relative displacements local to the contact region

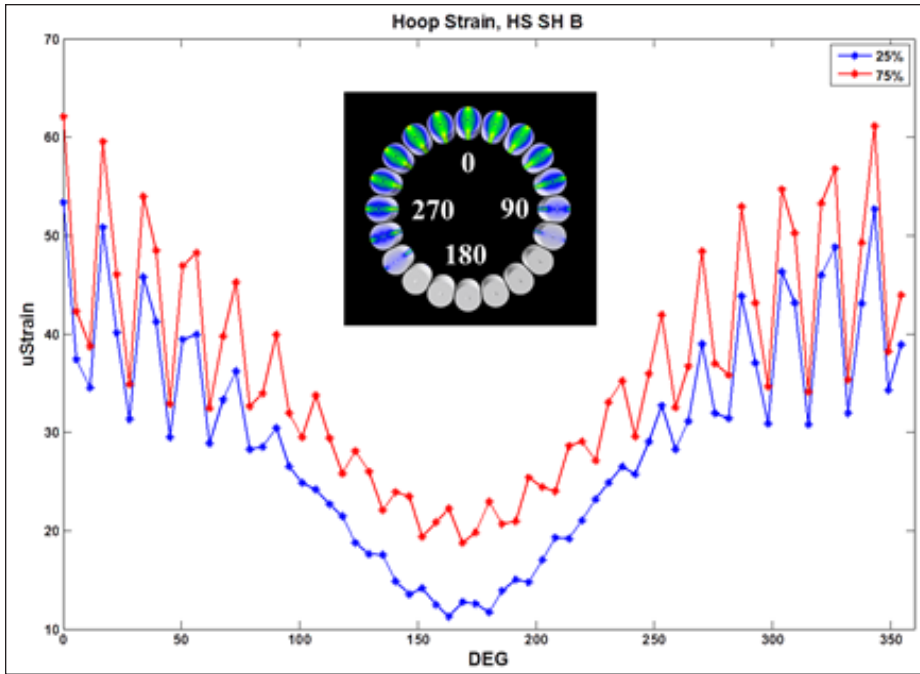

Figure 7 Unmodified outer raceway hoop strain of HS SH B for one-time step.

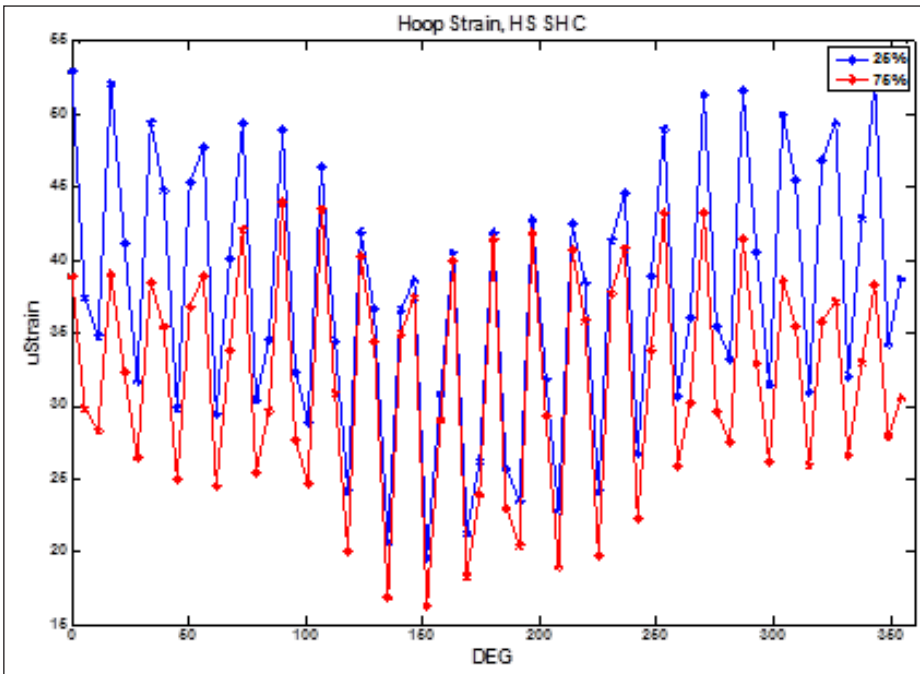

Figure 8 Unmodified outer raceway hoop strain of HS SH C for one-time step.

Location	Simulated peak-to-peak strains at groove locations with and without the modified bearing race.							
	HS SH B (micro-strain)				HS SH C (micro-strain)			
	No Groove		With Groove		No Groove		With Groove	
	25%	75%	25%	75%	25%	75%	25%	75%
A	19	23	133	150	18	11	103	81
B	3	10	47	5	21	19	134	163
C	2	4	-14	17	19	21	153	107
D	7	13	107	100	19	15	154	135

(Ref. 5). But in doing so, *Calyx* does not require a highly refined FE mesh.

High-Speed Shaft Analysis

The high-speed stage gears and bearings are acknowledged to be critical components of the gearbox (Refs. 1-2); there previously had been very little instrumentation of the high-speed shaft, gears, and bearings. During the next phase of testing, this portion of the gearbox was to be instrumented. In this next phase, tests were developed to evaluate the loads on the TRBs (Ref. 6). Gauges were placed in axial grooves machined into the outer race of the TRBs. Each bearing has four axial grooves, with two-gages-per-groove.

There was initial concern as to whether the strain levels would be high enough in the bearing raceways to provide an adequate signal-to-noise ratio. The outer race of the bearing is tapered; the groove geometry was tapered as well, with the intent of maintaining a constant radial thickness of the raceway along the groove.

In this analysis, contact was included in the model at all gear mesh locations and at the high-speed bearings; all other bearings were included as stiffness matrices. The high-speed, intermediate-speed, and low-speed stages are shown in Figure 3. The fully modeled bearings can also be seen, and are shown in detail in Figure 4, which also displays the naming convention.

Model parameters. An analysis was completed with and without the modified race under 100% torque loading conditions. The TRBs were preloaded with 70 micron of negative clearance to accommodate mounting preload and loads due to thermal expansion of the bearing components. The cylindrical roller bearing HS SH A includes 18 micron of diametric clearance. In this opposing TRB configuration, bearing HS SH C will carry the thrust load generated at the high-speed gear mesh, adding to the initial preload of that bearing and relieving the preload from HS SH B. Figure 5 shows the contact pressure distributions on a) HS SH B and b) HS SH C. It can be seen that all of the rollers in HS SH C are in contact; as mentioned previously, this bearing carries the thrust force generated at the gear mesh,

which keeps all rollers under load. HS SH B however, has approximately 30% of the rollers out of contact.

Bearing strain results. Figure 6 displays the numbering convention used for both TRBs. The first roller in each bearing is located at zero degrees—or top-dead-center (TDC) of the bearing—and increases clockwise while looking downwind (from the left, Fig. 2). The hoop strain was extracted around the circumference of the outer raceway (Figs. 7– 8). The strain was sampled at two axial locations, i.e.—at 25% and 75% of the axial length of the raceway. The results of this analysis are from one time step and can be viewed as if the race was unwrapped and laid flat on the page. Roller 1 is at TDC (0 degrees). The peaks correspond to roller positions; a peak indicates that a roller was directly under that location and a valley indicates that two rollers are straddling that point. The race with grooves has locations at 0° (Groove A); 90° (Groove B); 180° (Groove C); and 270° (Groove D). Differences in load distribution along the rollers themselves should result in shifts in strain values between the two axial locations, and could be used as an indication of roller load distribution. Figures 9 and 10 illustrate the strains extracted around the circumference of the outer race with the machined grooves; the groove locations are labeled. Table 1 shows the peak-to-peak, predicted strain indicating the strain caused by direct application of load by a passing roller.

Discussion

The grooves, as indicated in Figures 7-10, increased the simulated bearing race strains by as much as 300%. HS SH B had two groove locations that were either very lightly loaded or were outside the load zone completely—i.e., locations b and c—respectively. These locations did not see the same amplification as those located directly in the bearing load zone. In general the groove geometry increased strains by a considerable amount. One detriment to modifying the bearing outer race may be that the roller-to-roller load distribution could be affected by the modification. Figures 11 and 12 show the predicted roller loads of HS SH B and

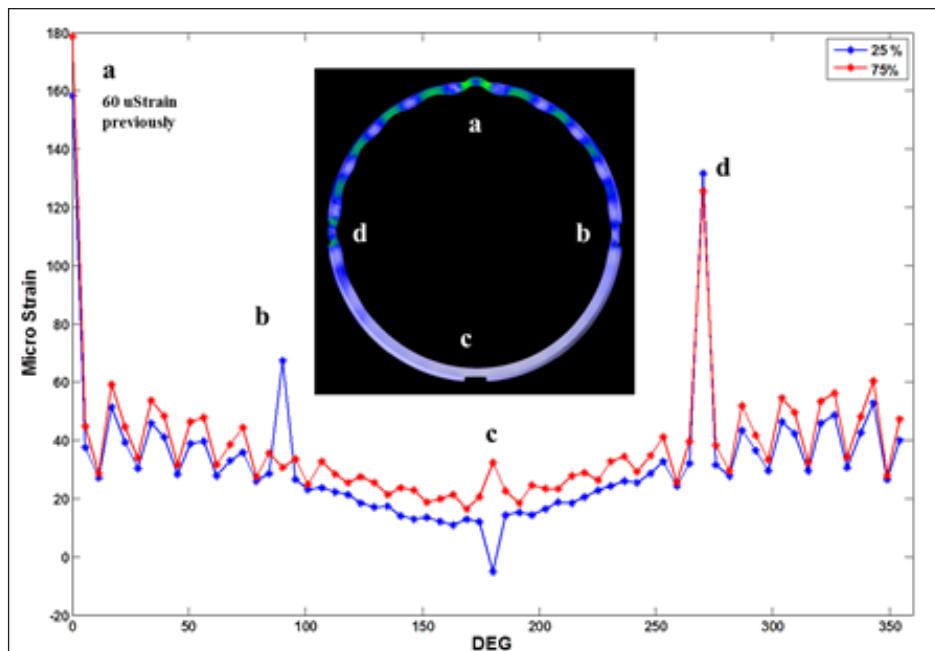

Figure 9 Modified outer raceway hoop strain of HS SH B for one-time step.

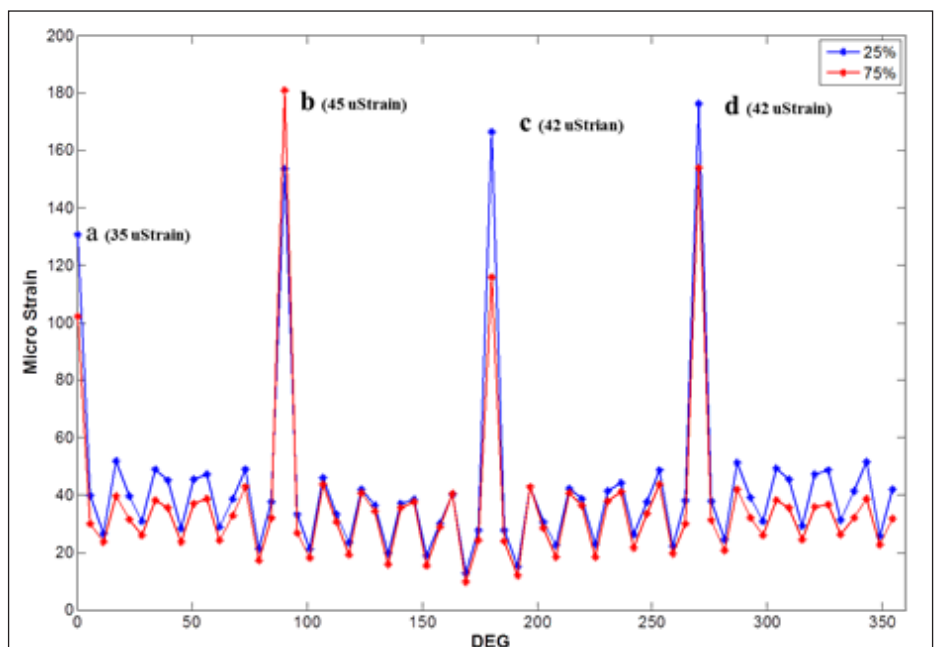

Figure 10 Modified outer raceway hoop strain of HS SH C for one-time step.

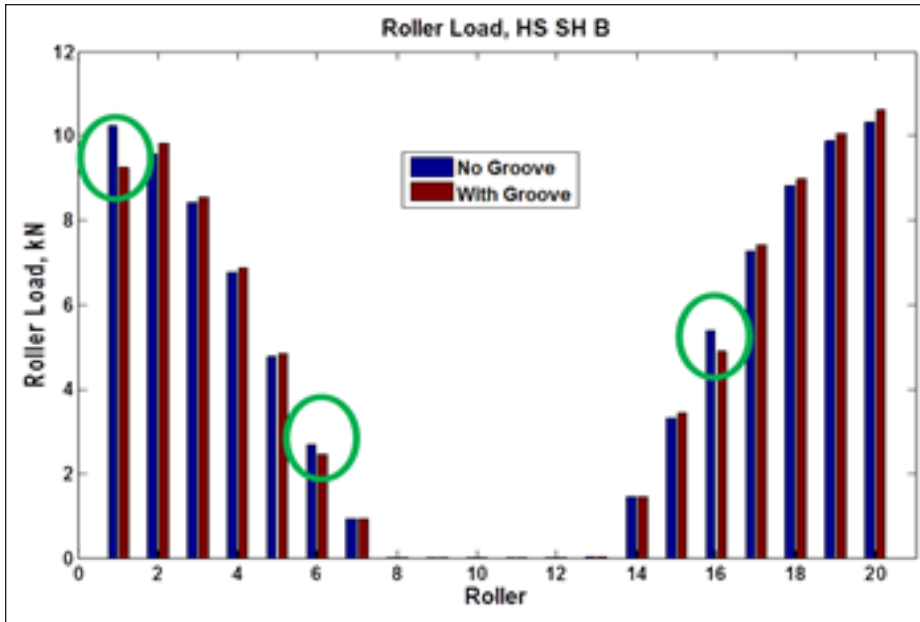

Figure 11 HS SH B roller loads — with and without modified raceway.

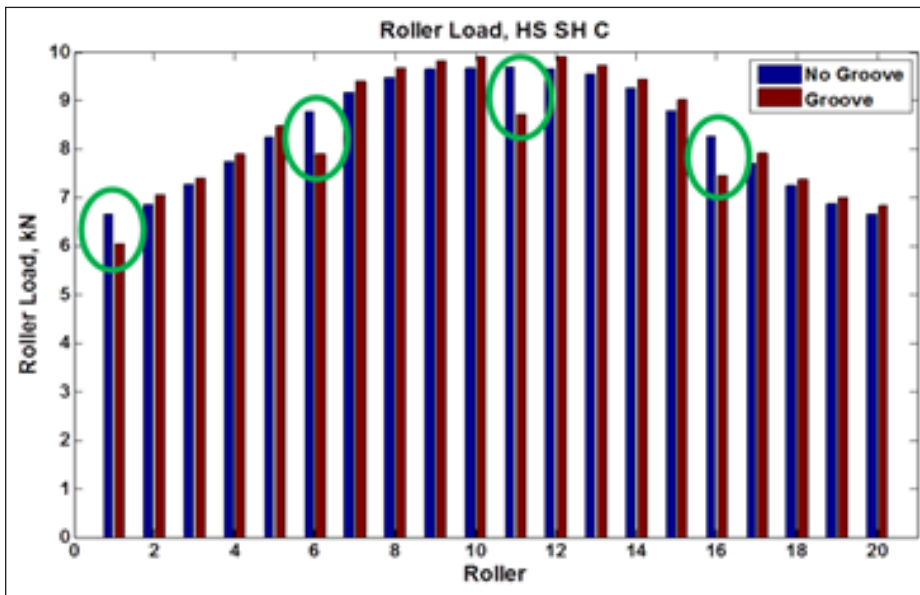

Figure 12 HS SH C roller loads — with and without modified raceway.

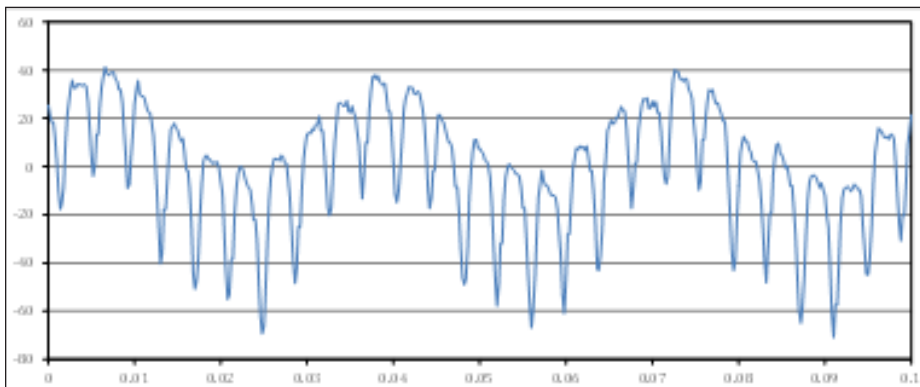

Figure 13 Measured modified outer raceway hoop strain in time for HS SH B, location "A" (0 deg), and axial position 75%.

HS SH C, respectively. Green-circled data points represent the locations of the outer raceway modifications; these figures show the total load carried by individual rollers for both the modified and unmodified outer raceway cases. Here the roller-to-roller load sharing is predicted to be minimally affected by the addition of compliance through the introduction of outer raceway grooves.

Implementation of Bearing Race Groove

The scheme discussed in this Section 2 has been implemented by the NREL Wind Energy group (Ref.6) and successfully tested. Its final implementation has an adjusted groove geometry that was applied to accommodate manufacturing considerations. Also, the bearing preload that was achieved is unknown, but was most certainly considerably lower than that used in the example for this paper. To demonstrate the fidelity of the signals, Figures 13 and 14 show 0-degree slot strains for HS SH B and HS SH C at 75% axial location, respectively.

Strain caused by the direct application of load by a roller on the outer raceway is represented in Table 2 as the average peak-to-peak-measured strain. As seen in Figure 13, there is quite a bit of variability in strain levels for each different roller passing. This variability is quite repeatable, with roughly every ninth roller passing corresponding to one shaft revolution.

It should be noted here that a torque trace taken from the shaft showed a significant once-per-revolution torque variation that seems to correlate well with the strain variations.

Table 2 shows that HS SH B carries a small amount of load in comparison to HS SH C. As noted earlier—and predicted in Section 2—this is due to the fact that the axial gear mesh load is supported by HS SH C, while the preload of HS SH B is reduced by this loading. In fact, for the 75% axial position of bearing HS SH B, it appears that virtually no load is carried by this end of the roller at positions C and D (Table 2). Because the analysis presented in Section 2 was performed assuming preload on this set of bearings, the simulations indicate more load carried by each of the bearings.

Conclusion

Here a full transmission model of a 750kW wind turbine gearbox was modified in order to assess bearing raceway modifications for measurement of strain in order to predict bearing load sharing and load distribution.

It is clearly apparent that the modification of the tapered roller bearing outer raceways — through the introduction of a groove — greatly increased the predicted strain in the raceway.

Simulations predicted that appreciable strain signals could be produced by introducing such grooves, and measurements show that to be true.

Improved strain predictions to be directly compared to the experiments may be attained by using exact groove geometries manufactured, as well as the known, bearing preload levels used in the experiments.

Acknowledgments. *This work was partially funded by a grant (GRT0023734/60030753) from the National Renewable Energy Laboratory (NREL). We would like to thank Jon Keller and Yi Guo of NREL for providing us with the test data, as well as the sponsors of the Gear and Power Transmission Research Laboratory for providing funding for this research. PTE*

References

1. Musial, W. and S. Butterfield. "Improving Wind Turbine Gearbox Reliability," *Conference Paper NREL/CP-500-41548*, pp. 1-3, 2007.
2. Errichello, R. and J. Muller. "Gearbox Reliability Collaborative: Gearbox 1 Failure Analysis Report," *Technical Report NREL / SR-5000-53062*, 2012.
3. Wilson, R., S. Walker and P. Heh. "Technical and User's Manual for the FAST_AD Advanced Dynamics Code," *OSU/NREL Report 99-01*, Oregon State University, Corvallis, Oregon, 1999.
4. "Transmission 3D User's Manual," *Advanced Numerical Solutions, LLC, www.ansol.us*, 2014.
5. Vijayakar, S. "A Combined Surface Integral and Finite Element Solution for a Three-Dimensional Contact Problem," *Int. J. Numer. Methods Eng.*, 31 (3), 525-545, 1991.
6. Keller, J., Y. Guo and B. McNiff. "Gearbox Reliability Collaborative: High-Speed Shaft Tapered Roller Bearing Calibration," *Technical Report NREL/TP-5000-60319*, Oct. 2013.

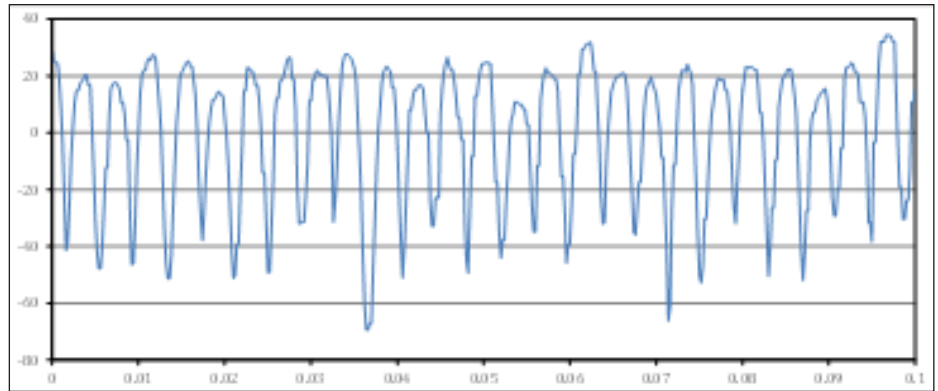

Figure 14 Measured modified outer raceway hoop strain in time for HS SH C, location "A" (0 deg), and axial position 75%.

Location	HS SH B (micro-strain)		HS SH C (micro-strain)	
	With Groove		With Groove	
	25%	75%	25%	75%
A	47	36	74	73
B	11	15	62	43
C	12	1	74	98
D	6	1	74	65

For Related Articles Search

simulation

at www.powertransmission.com

Jason Austin graduated from the GearLab at Ohio State University in June, 2013, with an M.S in mechanical engineering. While there he authored a doctoral thesis on the FEA of a wind turbine gearbox via collaboration with the National Renewable Energy Laboratory and the Gearbox Reliability Collaborative. Austin is currently employed by DNV GL as a pipeline integrity engineer, tasked with providing technical consultation to the oil and gas industry.



David Talbot is a research scientist — mechanical and aerospace engineering — at The Ohio State University, specializing in gear system efficiency, manufacturing and geometry, and load distribution simulation.



Dr. Sandeep Vijayakar is founder and president of Advanced Numerical Solutions (ANSOL). He received his PhD from The Ohio State University, where he now serves as an adjunct faculty member. His company — ANSOL — specializes in the finite element contact analysis of gears. Vijayakar is credited with authoring the Calyx computer program, designed for the static and dynamic analysis of geared systems.

Dr. Donald Houser is Professor Emeritus of Mechanical Engineering and founder of the Gear Dynamics and Gear Noise Research Laboratory (GearLab) at Ohio State University. Dedicating his efforts and knowledge to gear dynamics research for over 45 years, he has also consulted for numerous companies. Dr. Houser is a past chairman of ASME's Power Transmission & Gearing, and Gear Noise Committees; is an active member of the AGMA Noise Committee; and has contributed gear noise-related chapters to *The Gear Handbook* (D. Townsend, editor) and *Handbook of Noise and Vibration Control* (M. Crocker, editor). Dr. Houser is also a prolific author of technical papers — presented at conferences and other proceedings worldwide — of which many have appeared in this publication.



Global Industrial Outlook: Houston, We Have a Problem

By Brian Langenberg, CFA

With two armed conflicts underway impacting economic performance in Eastern Europe and the Middle East, we continue our investment stance of “Buy on the Sound of Cannons—Selectively”—but readers of *Power Transmission Engineering* should not be sanguine.

Geopolitics is beginning to exert significant pressure on several end markets: I specifically refer to oil price. West Texas Intermediate or WTI has dropped from its \$95-105 trading range in late spring to about \$75—about a (25%) drop despite two ongoing conflicts because of excess supply.

In our view this is not an accident. We call it “the Putin’s Zipper Trade” because Vladimir has pretenses of greater Russian (Soviet?) glory, and at \$110-oil, his budget balances and he struts around just the way the above “label” implies. In my view the Saudis are opting to attack him the best way possible—by cutting his government’s revenue by over 20%. About 85% of Russian government revenues are driven by natural resources. Lower commodity price correlates to a stronger dollar and is very, very bad for his government and position. The counterargument is that Saudi Arabia is seeking to defend market share in the face of rising—but higher-cost—U.S. production, where higher-cost basins become less attractive, particularly oil sands, when oil drops below \$80. We disagree.

WEST TEXAS INTERMEDIATE – LAST 2 YEARS
\$ Per barrel

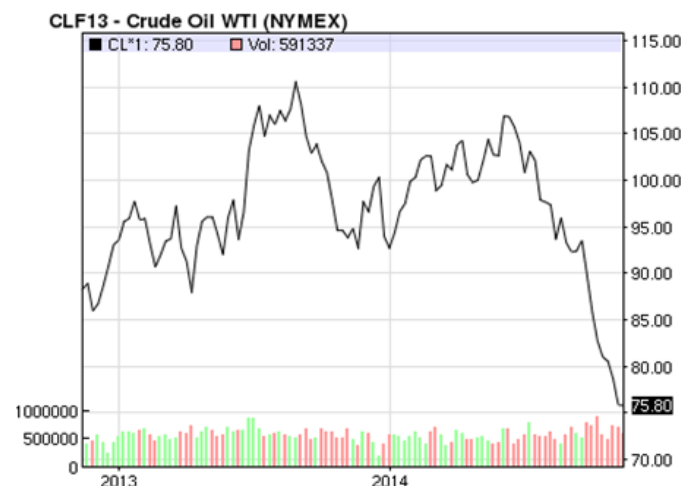

We will return shortly to how this hurts you.

WHAT MATTERS:

U.S. best growth spot. Non-residential construction, consumer durables (auto, housing) and gradually improving employment will offset weaker commodity-based demand.

Europe. Marginal hit (Nordics, resource-related parts of German economy) by conflict in Eastern Europe. Rest of

continent still struggling with weak banking system, but that is nothing new.

Middle East. Buying weapons is in vogue (UTX), old construction projects (Otis) are getting finished, but new ones? Oil & Gas activity should remain strong even with production cuts because mature fields require more capital and the region is seeking to capture more of the value stream.

Brazil. Continues to get whacked. Exports are down (40%) the last two years already (weak China) on lower iron ore prices and volume. Petrobras story (oil) being hurt by lower oil price and emerging criminal charges/graft between Petrobras and people close to President Dilma Rouseff. If that isn’t enough pain for you, weakening Japanese Yen will further hurt construction equipment pricing in the region.

War matters, Ebola does not. Warfare in Eastern Europe and Iraq caused further order and revenue push-outs in 3Q (Flowserve, others). Improving defense after-market revenue likely continues.

Oil & Gas: U.S. midstream and downstream are bullet-proof but *upstream spending will get tweaked downward*. Petrobras scandal may create further incremental uncertainty with your OE customers but the offset is Mexico is finally serious about investing in offshore exploration and production. Netting it all out though—oil price down (25%) = (25%) lower industry revenue = bad for you. Most of your customer base is claiming it will have little impact. They are wrong.

The challenge isn’t 2014—its 2015! Upstream represents, by far, the biggest chunk of capital spending and while at least half will be aftermarket/production driven, a significant piece includes incremental exploration and, with oil below \$80, marginal production. When wells lose money they get capped.

Potential second derivative weakness could occur in a broad range of end markets including construction equipment, land based power generation (small p not BIG P), and ancillary products and services. To be clear, we do not anticipate a steep decline, but would be amazed if energy sector capital spending does not decline in 2015. Other end markets....

Mining: Still awful—but hard to get worse; aftermarket is now stabilized.

Power Generation: U.S. power generation remains weak, owing to efficiency gains throughout the economy and lack of regulatory support for new (Wind) construction. Recent election results should have marginal impact on ability of administration to pressure coal sector (generation and the commodity itself), but there are bigger fights looming. Globally the industry looks good—including coal and gas.

Transportation Infrastructure: More pothole filling; no major infrastructure upgrade anytime soon. Immigration

COMPANY	TICKER	CAPEX (M)		% CHG
		2013 A	2014 E	
EQUIPMENT & SERVICES				
Schlumberger	SLB	3,943	3,800	(4%)
Halliburton	HAL	2,934	3,000	2%
Baker Hughes	BHI	2,100	2,000	(5%)
National Oilwell Varco, Inc.	NOV	669	600	(10%)
Weatherford Int'l Ltd.	WFT	1,575	1,275	(19%)
Transocean	RIG	2,238	2,600	16%
Seadrill	SDRL	4,699	4,500	(4%)
		18,158	17,775	(2%)

fight poisons well — not to mention ObamaCare — for everything that was pragmatically possible, including the corporate tax reform that could have brought funds back to reinvest.

Machinery: Capital is scared, translating into project push outs at E&C firms even as current production is up year over year. Agriculture is rolling over in the U.S. and Latin America. The Russia growth story is dead in the near term. U.S. truck build rolls along on replacement demand. Construction equipment orders have weakened, though utilization remains high in the U.S. while Europe is flattish and China declines. Non-residential activity and utilization supports a constructive view.

Consumer (auto, appliances): Old cars = continued U.S. strength. Auto-related end-markets will remain solid. U.S. residential recovery is on-track and will further support construction equipment demand.

Aerospace/Defense: Strong commercial build rates — coupled with two shooting wars and depleted U.S. inventories — argue for a continued recovery in aftermarket activity. Long-term we expect a U.S. defense recapitalization, but not before 2017 authorization, given the current Administration. We do think it happens no matter which party captures the White House in 2016, because anybody except the total infantile have woken up to realize you need to have both a) a foreign policy, and b) a big stick to back it up.

FOCUS COMPANIES: HALLIBURTON (HAL), BAKER HUGHES (BHI)

Precipitous drops in oil price often lead to M&A activity in an effort to drive out costs and protect or increase margin. To that end Halliburton recently announced an offer for industry rival Baker Hughes that would combine the #2 and #3 U.S.-based players. Diving into the capital spending data earlier we note that combined expected capex is about \$5 billion in 2014.

The merger plan calls for \$2 billion in annual cost synergies. Experience tells us that large deals hurt capital spending in the near-term (uncertainty, distraction of people worrying about their jobs), and post deal (paying for the merger through greater efficiencies and elimination of overlapping functions, people and assets).

Nearly \$2 billion of annual cost synergies

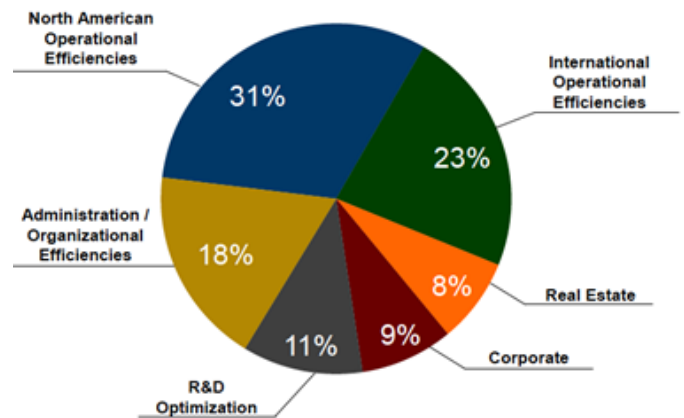

Using their charts, about \$600M (31%) relates to U.S. operational efficiencies, but also \$220 million of R&D optimization.

Baker Hughes related projects carry higher risk. In reality there are no mergers — only acquisitions. Post-deal BHI shareholders will own 36% of the company. If two projects are marginal, the Halliburton project is more likely to win. You will want to think about this down to the **Basin** level.

Given both lower oil price and this merger, this is a good time to really focus on which Basins, OEMs and equipment service organizations your revenue stream is tied to in the Energy sector. **PTE**

Brian K. Langenberg, CFA, has been recognized as a member of the Institutional Investor All-America Research Team, a *Wall Street Journal* All-Star, and *Forbes/Starmine* (#1 earnings estimator for industrials). Langenberg speaks and meets regularly with CEOs and senior executives of companies with over \$1 trillion in global revenue. His team publishes the *Quarterly Earnings Monitor/Survey* — gathering intelligence and global insight to support decision-making. You can reach him at Brian@Langenberg-llc.com or his website at www.Langenberg-llc.com.



Maxon Motor

HELPS POWER ROSETTA MISSION

On Nov. 12, the European Space Agency (ESA) successfully landed a small laboratory on Comet 67P/Churyumov-Gerasimenko (Chury).

The lander featured ten instruments which may provide important clues to the origin of life. Two DC motors made by Maxon Motor were on board the mission.

For the first time in the history of space exploration, scientists have access to data from a comet's surface. The Philae lander has a mass of 100 kilograms and features ten instruments. Maxon Motor, a Swiss-based drive specialist, provided two DC motors with a diameter of 13 millimeters each. These motors were used to lower the APXS instrument to the ground.



The APXS is an alpha x-ray spectrometer that is used to record the chemical composition of Chury and provide information on the presence of key elements such as carbon and oxygen. The instrument was developed at the Johannes Gutenberg University Mainz.

The individual instruments will now be activated automatically in sequence. The drives were then evaluated to determine if they survived the 10-year journey unscathed.

Oerlikon Drive Systems

PRESENTS 'SHIFTING SOLUTIONS' AT ITALIAN CONFERENCE

"Shifting Solutions" and the new fast track prototyping and small batch manufacturing facility from Oerlikon Drive Systems were presented at the EIMA International Agricultural and Garden Machinery Exhibition, in Bologna, Italy, from Nov. 12-16.

Oerlikon Drive Systems showed synchronizers and clutch packs that help to deliver increased efficiency, improved vehicle performance and reduced cost. A special area was dedicated to the new fast track prototyping and small batch manufacturing facility for cylindrical gears, synchronizers and drive subassemblies.

Oerlikon Graziano, a brand of Oerlikon Drive Systems Segment, produces around a million syn-



chronizers per year for agricultural tractors, construction equipment, passenger cars and trucks. The company exhibited products from a range that runs from 62 to 170 millimeters in diameter and includes single, double and triple cone solutions, and its range of carbon synchronizers that help to increase the reliability and longevity of construction and agricultural transmissions.

David Brown Gear Systems

OPENS FACILITY IN PHILIPPINES

David Brown Gear Systems, a supplier of industrial gearboxes and aftermarket services for applications in the world's core industrial sectors, announced the opening of its new industrial gearbox service and repair facility in Subic Bay Freeport Zone, Philippines.

David Brown Gear Systems (Philippines), Inc. is located in the heart of the region's growing industrial sectors and is fully equipped with state-of-the-art gearbox strip, condition assessment, repair, rebuild, assembly and test facilities.

Utilizing more than 150 years of gear engineering and service experience, David Brown's new service center will repair and upgrade gearboxes in industrial applications including mines, power stations, cement and sugar processing plants as well as oil and gas facilities and marine vessels.

"David Brown works in industries where maximum process availability is critical and we are proud to be the only industrial gearbox OEM operating a dedicated service center in the Philippines," said Scott Gilmour, general manager of David Brown Asia. "Our new service center in Subic Bay brings us even closer to our valued customers and is a major milestone in the company's plan to deliver premium gear engineering expertise throughout Asia."

British Ambassador to the Philippines, Asif Ahmad, welcomed David Brown's investment in Subic Bay.

"It is good to see another world-leading British company choosing the Philippines for its operations in this fast growing region," said Ahmad. "Filipino businesses in industries such as mining, energy and construction will benefit from David Brown's experience and expertise. With more than 150 years in the business, David Brown offers top-notch specialist transmission engineering and repair services and adheres to the highest global quality assurance standards. I am also impressed by David Brown's commitment to transfer technology for the Philippines; particularly to new employees the company will be recruiting."

Oerlikon Graziano

SLOTTED AS 'SUPPLIER OF THE YEAR' BY CLUB CAR

Oerlikon Graziano was recently awarded "Supplier of the Year" by Club Car, a brand of Ingersoll Rand. The award was announced during a ceremony that took place in Augusta, Georgia during Ingersoll Rand's annual Supplier Day.



"This is the second consecutive year that we received an award from Club Car," said Paolo Mantelli, Oerlikon Graziano's Head of Performance Automotive.

The relationship between Club Car and Oerlikon Graziano started in 1994 with the development of electric axles.

In 2013, Oerlikon Graziano was awarded in the program "Supply Chain Partners Performance Excellence," in recognition of contributions in several Value Management Program activities during 2012. This year, Oerlikon Graziano was chosen as "Supplier Executive of the year," with Eric Powell, director of strategic sourcing at Club Car and Sheila Tierney, vice president of procurement at Ingersoll Rand, handing over the plaque directly to representatives of Oerlikon Drive Systems.

PTDA

HOLDS 2014 INDUSTRY SUMMIT, ELECTS AJAY BAJAJ PRESIDENT FOR 2015

Nearly 600 power transmission and motion control industry representatives from over 250 Power Transmission Distributors Association member companies attended the PTDA 2014 Industry Summit. Along with an additional 230 spouses, companions and guests, the top executives convened from Oct. 22-25 at the Hilton Orlando Bonnet Creek in Orlando, FL.

At the summit, the PTDA elected its 2015 Board of Directors and Manufacturer Council. **Ajay Bajaj**, president of Rotator Products Limited in Woodbridge, Ontario, Canada will become the PTDA's president in 2015. **Cliff Bannon**, Eastern sales manager for Isostatic Industries Inc., in Chicago, IL will assume the duties of the PTDA Manufacturer Council chair in 2015, succeeding Brian Kolman, president of Brewer Machine & Gear Co. in St. Louis, Mo.



NES

RECEIVES WESTERN NEW YORK MANUFACTURING AWARD

Napoleon Engineering Services (NES) was honored by Business First of Buffalo with a Western New York Manufacturing Award for Operational Excellence at a ceremony held on May 13. NES was one of 21 manufacturers honored.

Founded in 1997 by lifelong Western New York resident Chris Napoleon, the privately held NES is an independent, single-point resource for bearing inspection, bearing testing and custom bearing manufacturing. With core competencies in high-precision custom ball and roller bearings using super elastic Ni-Ti alloys, wear-resistant, high-life materials and coatings, and advanced design technologies, the company has grown into a key resource for bearing manufacturers, distributors and OEMs across a diverse array of markets.

"It is beyond humbling to see the growth of NES over the years, since its beginnings in a spare bedroom and a half garage bay of my home in 1997," Napoleon said. "We would not be where we are today without the support of our loyal customers, employees and the Western New York community. This is our home. And we look forward to continuing to build and strengthen our presence here in the years to come."



www.nesbearings.com

Pat Wheeler

RECEIVES INAUGURAL WENDY B. MCDONALD AWARD

To honor the memory of Wendy B. McDonald, one of the power transmission/motion control industry's pioneers, the PTDA Foundation has established the Wendy B. McDonald Award.

The award acknowledges a woman who established herself as a critical contributor to her company's success and affected positive change within the power transmission/motion control industry. The first recipient of the Wendy B. McDonald Award was Pat Wheeler of Motion Industries (Canada).

Wheeler joined BC Bearing (now Motion Industries Canada) in 1980 as a shipper/receiver. She moved into inside sales



and then to office manager in 1990. In February 2003, she was appointed branch manager—the only female branch manager in the company at that time. In 2008, she was recognized by McDonald at the annual sales meetings for almost single-handedly managing her territory.

In her acceptance speech during the PTDA Industry Summit in Orlando, FL, Wheeler credited McDonald with being her idol and mentor because she paved the way for her to feel confident enough to accomplish all that she has in her 34 year career.

McDonald's daughter, Penny Omnes, and son, Scott MacPherson, were on hand to present Wheeler with the award.

QA1

HONORED WITH TWO SEMA GLOBAL MEDIA AWARDS

QA1, a manufacturer of high-performance suspension components, has been honored with two Specialty Equipment Market Association (SEMA) Global Media Awards for its carbon fiber driveshafts and Mopar Rear Suspension Conversion System.

SEMA introduced the Global Media Award program in 2004 to highlight the wide appeal of specialty-equipment products to enthusiasts on every continent. Products are reviewed by a panel of 35 top automotive journalists from more than 20 countries around the world and recipients were recognized in an evening program during the 2014 SEMA Show in Las Vegas, Nevada.



QA1's carbon fiber driveshafts, which are currently offered for street performance vehicles as well as dirt late models, are a major new offering from QA1's Advanced Materials Division. These driveshafts are lighter, stiffer, stronger and safer than aluminum and steel driveshafts and are filament wound in-house using 3MTM Matrix Resin that is exclusive to QA1 performance driveshafts.

"QA1 is redefining industry standards by performing the filament winding in-house, which allows us to make carbon fiber driveshafts specific to each application," said Travis Gorsuch, QA1's Director of Advanced Materials. "We're very excited for them to be recognized as a high-quality product that is relevant in multiple markets."

The second Global Media Award for QA1 was for the Mopar Rear Suspension Conversion System, a revolutionary bolt-in conversion from leaf springs to coil-overs for Mopar A-Body vehicles. The system utilizes a 6-link suspension that builds upon the traditional 4-link system and replicates its geometry while still mounting to the existing chassis mount locations.

"It's an honor to be recognized for this rear system," said Karl Hacken, vice president of engineering at QA1. "We've put a lot of time into development so that it would be a practical bolt-in system, allowing it to be available to a wider audience that may not be comfortable cutting or welding on their vehicles. The awards are a testament to QA1's emphasis on creating and producing performance-based products that have wide appeal."

Timken

ACQUIRES ASSETS OF REVOLVO LTD.

The Timken Company announced it has reached agreement with Eriks NV to acquire the assets of Revolvo Ltd., a specialty bearing company based in Dudley, U.K.

Revolvo makes and markets ball and roller bearings for industrial applications in process and heavy industries. The company's split roller bearing housed units are used by mining, power generation, food and beverage, pulp and paper, metals, cement, marine and waste-water end users. In 2013, Revolvo posted sales of approximately \$8.3 million.

BEYTA GEAR SERVICE

**PUTTING
A LIFETIME
OF
GEAR
DESIGN
EXPERIENCE
TO WORK FOR YOU**

- Reverse engineering
- Gearbox upgrades
- Custom gearbox design
- Specification development
- Project management
- Vendor qualification

- Design reviews
- Bid evaluations
- Tooling design
- Customized gear training
- Equipment evaluation
- Custom machine design

Charles D. Schultz
chuck@beytagear.com
[630] 209-1652

www.beytagear.com

“We’re pleased to have Revolve become part of Timken,” said Hans Landin, product line executive, power transmission and engineering systems for Timken. “The Revolve team brings a wealth of experience and well-established customer relationships, and their split roller bearing housed unit line will strengthen the Timken portfolio of bearing and power transmission products.

“These split bearing housed units bring additional breadth to our industrial product solutions while addressing specific customer needs,” Landin added. “Revolve’s expertise and quality product line, coupled with Timken’s global reach and market access, will allow us to leverage resources to improve competitiveness and accelerate the growth of housed unit products, particularly in Europe and Asia.”



Revolve’s line of split-to-the-shaft roller bearing housed units enables the bearing to be fitted without requiring access to the shaft ends. Instead, it can be built around the shaft, which reduces downtime because no other drive components must be removed during installation or for maintenance. The product design accommodates misalignment, helps extend up-time, reduces maintenance costs and increases plant efficiency for end users.

The acquisition is subject to certain customary closing conditions, including employee consultation. Terms were not disclosed.

Kevin McCloskey

RECEIVES WARREN PIKE LIFETIME ACHIEVEMENT AWARD

The Power Transmission Distributors Association (PTDA) has named Kevin McCloskey, Category Manager at Kaman Industrial Technologies Corporation, the 24th recipient of its Warren Pike Award for lifetime achievement in the power transmission/motion control (PT/MC) industry.

McCloskey received the award at the association’s Industry Summit in Orlando, FL. The award was established in 1984 to honor individuals who have demonstrated outstanding, continuous, long-term support of PTDA and the PT/MC industry.

McCloskey has served on numerous PTDA committees and task forces and is currently a member of the Research & Innovation Committee. McCloskey also served on the Board of Directors from 1996-2002 and as the board president in 2001.

“Kevin has been a great partner through the years for Dodge,” said Jeff Moore, vice president of marketing and mechanical power transmission for Baldor Electric Company. “He collaborates well with our whole organization and works to achieve not only the best solution for Kaman, but also for the manufacturer as well. The thing I appreciate about Kevin is his transparency. If he doesn’t like something he will tell you. It’s easy to have a trusting relationship when you can have frank conversations with a channel partner and Kevin has always been one of a handful of people who will roll up his sleeves and work to achieve a mutually beneficial result.”

GET THE BIG PICTURE

Subscribe today!

GLOBAL INDUSTRIAL OUTLOOK

Concise, visual, information rich analysis of global manufacturing demand and trends organized by geographic regions and key industry verticals. Built on proprietary, granular collection and organization of core growth trends in orders and sales from 55 key global companies.

Published Quarterly: February, May, August, November

Regular price: \$400 (only \$350 for PTE subscribers)

Money back guarantee

Langenberg &
Company

Subscription requests to:

Ewa@Langenberg-llc.com

www.Langenberg-LLC.com

USA

RESOURCES

Oil & Gas

Mining



POWER & ENERGY

Generation

Transmission

Distribution



TRANSPORTATION

Road

Rail

Marine



MACHINERY

Construction

Mining

Truck

Agriculture



AUTOMATION

Process

Industrial



FLOW CONTROL



IND. MACHINERY, GEN IND.

CONSTRUCTION

HVAC

C&I

Residential



CONSUMER

Automotive

Appliances

Electronics



AVIATION

Commercial

Military



Energy Efficiency, Configurable Solutions Highlight Pack Expo

Randy Stott, Managing Editor

A wide variety of companies displayed mechanical power transmission and motion control technologies at Pack Expo, held in November in Chicago. The event, which is the largest packaging and processing trade show in North America, attracted more than 48,000 attendees, according to show owner and producer PMMI. The four-day event included 2,352 exhibiting companies, an increase of more than 19 percent from the previous show in 2012.

“Pack Expo International 2014 was definitely a success,” said Jim Pittas, senior vice president of PMMI. “Exhibitors sold machines right off the show floor and collected high quality leads from the steady flow of attendees.”

Mechanical components and motion control were definitely a big part of that mix. Following are some of the highlights from power transmission and motion control exhibitors.

Bosch Rexroth

INCREASES THROUGHPUT WITH ADAPTIVE SYSTEMS

Adaptive Systems technology minimizes unwanted movements like oscillations and vibrations, increasing process throughput by up to 50 percent.

Bosch Rexroth offers Adaptive Systems motion control technology directly at the drive level to reduce unwanted movements in industrial machinery. The technology alleviates movements including oscillations, vibrations, sloshing and sway.

Vibrations and oscillations are simple, repetitive motions, but they're governed by complex factors of wave physics. The complex nature of waves often makes traditional vibration control methods ineffective. Because implementing vibration damping and avoidance techniques requires a control system that can quickly adapt to varying process, material and application changes, Rexroth offers Adaptive System technology directly at the drive level, rather than at the higher control level.

Rexroth Adaptive System motion control can handle high-speed inputs and deterministic events with closed-loop response times. Current closure can be accomplished in 62.5 microseconds, speed loop closure in 125 microseconds, and position closure in 250 microseconds.



Rexroth Adaptive Systems technology is implemented from the company's IndraMotion MLD drive-based motion logic controller. Rexroth IndraDrive intelligent servo drives with sensors monitor the status of axis mechanics. Additionally, Rexroth Productivity Agent software uses the drive as an intelligent sensor to monitor, analyze and reduce vibrations in real time.

For more information:

Bosch Rexroth Corporation
www.boschrexrothusa.com

Emerson Power Transmission

INTRODUCES UPGRADED CONVEYOR CHAIN

Emerson's Power Transmission Solutions business introduced its new System Plast NG Evo conveyor chain, featuring a proprietary, low-friction FDA-approved material for dry conveying in food packaging applications.

“NG Evo builds on the success of original NG chain, which is widely used for dry conveying in the bottling industry,” said Jeff Himes, System Plast Senior Product Manager. “The new chain provides a higher breaking load, greater elasticity, lower coefficient of friction and much greater abrasion

resistance than the original. NG *Evo* significantly expands options for dry conveying to meet sustainability and water conservation goals, which will grow in importance for food packaging as the U.S. already grapples with regional water shortages.

“All of the physical properties of the original NG chain have been enhanced to meet specific challenges in food processing applications,” Himes added. “In addition, beverage handling conveyors are typically lubricated with soap and water

Brother Gearmotors

EXPANDS RANGE FOR NORTH AMERICAN CUSTOMERS

Brother Gearmotors, a manufacturer of sub-fractional AC gearmotors and reducers for the packaging, food & beverage and unit handling industries showcased several new benefits for customers in North America.

Gearmotors from Brother are compact in size, energy efficient and sealed for life, says Matthew G. Roberson, senior director for OEM and gearmotor business. Each model comes with a long-lasting protective paint coating whose electrostatic application assures a consistently tough, chemically-resistant coating designed to withstand especially harsh production environments.

According to Roberson, Brother customers who have installed Brother gearmotors often become customers for life. Durability and reliability are hallmarks of the Brother product line, he says. All gearmotors carry a high-grade grease standard, which means they are lubricated for the life of the product, helping to eliminate costly downtime for lubrication changes.

At its booth, Brother announced new bore sizes that open up a broader potential customer base for the company's gearmotors.

In addition, this summer Brother Gearmotors moved into a new world-class manufacturing facility, based in Bartlett, Tennessee. The modernized assembling facility - both ISO 9001:2008 and ISO 14001:2001 certified - allows Brother Gearmotors to shrink lead times for customer orders to an estimated three days. On-site technology also makes available a broader product mix to North American customers, including 16 different gear ratios and six voltage options. The facility will be a North American complement to the primary gearmotor factory, which has produced more than 10 million units over its 40-year history.

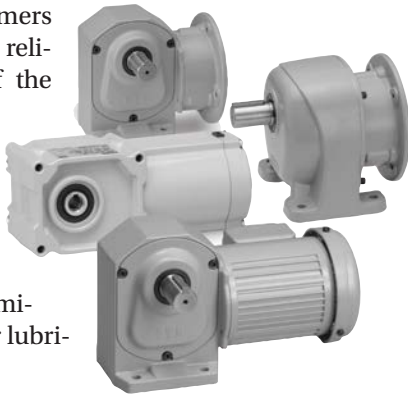

that uses two to three times more water than goes into the finished product.”

For more information:

Emerson Power Transmission Solutions
Phone: (859) 727-5263
jeff.himes@emerson.com
www.emerson-ept.com

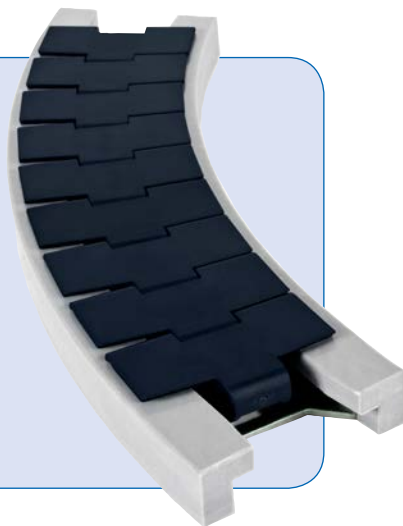

Igus Energy Chains

SIGNIFICANTLY REDUCE DRIVE POWER

Recent tests and sample calculations performed at igus' test laboratory prove energy consumption can be drastically reduced by using the right cable

carrier material with a sophisticated design, especially in long-distance, high-load applications. If Rol E-Chain—a specially designed cable carrier with

built-in wheels that roll instead of glides to facilitate travel over long distances—is used, the friction factor is drastically reduced from 0.3 to less than 0.1. This correlates to a 37 percent reduction in drive power with Rol E-Chain when compared to a traditional gliding application, as well as a significant decrease in overall costs.

Metal cable carriers are being replaced more and more by plastic Energy Chains because they are lightweight, require no lubrication and can withstand even the toughest applications.

For more information:

Igus Inc.
PO Box 14349, East Providence, RI 02914
Phone: (800) 521-2747
Fax: (401) 438-2200
sales@igus.com
www.igus.com



Ringfeder Power Transmission

ANNOUNCES NEW LOCKING ASSEMBLIES

New locking assemblies from Ringfeder include a central lock nut for safe and backlash-free clamping in a matter of seconds. Labeled the RfN 7070, RfN 7075, RfN 7085, and RfN 7090 series, these locking assemblies are designed for easy mounting, compact dimensions and a safe connection between the shaft and hub.

Shaft-hub connections in modern transmission systems require smaller, faster and more powerful technology. Examples include applications with backlash-free synchronous transmissions powered by compact servo or multiphase motors, where positioning is critical. Conventional joints with keyways, grub screws and simple bushings do not guarantee zero backlash in such precision applications.

For more information:

Ringfeder Power Transmission
Phone: (201) 666-3320
sales.usa@ringfeder.com
www.ringfeder.com

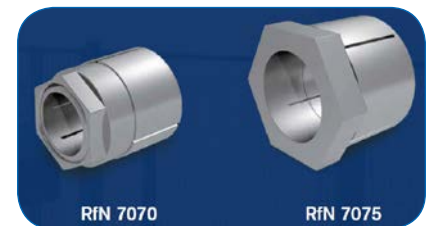

Motors and Motion Meet in St. Louis

SMMA 2014 Fall Technical Conference Held

Jack McGuinn, Senior Editor

The motors might be small, but the big-brain technology driving these electrical wonders was on full display at the 2014 Small Motor & Motion Association Fall Technical Conference, convened November 4-6 in St. Louis, MO.

SMMA, the manufacturing trade association (120 members strong) that tends to the best interests of the electric motor and motion control industries — including manufacturers, suppliers, users, consultants and universities — played gracious host to a wide array of presenters from an equally diverse range of sources — from academia to the federal government. Like gears, motors are most everywhere, as evidenced by SMMA's membership (consumer-, public interest-, national defense- and commercial-oriented) demographic which includes: appliance; transportation; medical equipment; office automation and computers; aerospace; and industrial automation. The association's mission: To "serve as the principal voice of the electric motors and drives industry" and to provide a forum to "develop, collect and disseminate technical and management knowledge."

"Collect" and "disseminate" indeed; check out this sampling of Abstracts of Conference presentations. They reflect the findings of many hours, days, months — maybe years in some cases — of pre-competitive R&D conducted in conjunction with — and on behalf of — SMMA's members. Even a cursory glance confirms that many of these presentations — some works-in-progress — conjure and explicate new motor-and-motion technologies attending numerous applications/industries of intrinsic value and importance of some kind to various sectors of the U.S. economy and security. Such as:

The Use of Thin Lamination Materials in Motors. Kamran Ramezani, President, Ramezani and Associates.

Fluorinated Greases for Extended Bearing Life in Motors. Carl Walther, Senior Technical Service Engineer, Dupont.

Designing Small Brushless Servo Motors. Daniel B. Jones, President, Incremotion Associates Inc.

Permanent Magnet Motors for Industrial Applications. Emmanuel B. Agamloh, PhD, Senior Motors and Drives Consultant, Advanced Energy.

Challenges in the Design of Very High RPM Motors. George Holling, Technical Director, Rocky Mountain Technologies, Inc.

Mosolver: Robust Feedback for Harsh Environments. Don Labriola, PE, President, QuickSilver Controls Inc.

Smaller - Faster - Hotter: Market Direction and Material Advancements. Aaron Williams, Project Manager-Machine Applications, Arnold Magnetic Technologies.

Magnetic-Mechanical Co-Simulation for Electric Machines. Adrian Perregaux, Consulting Representative, Infolytica.

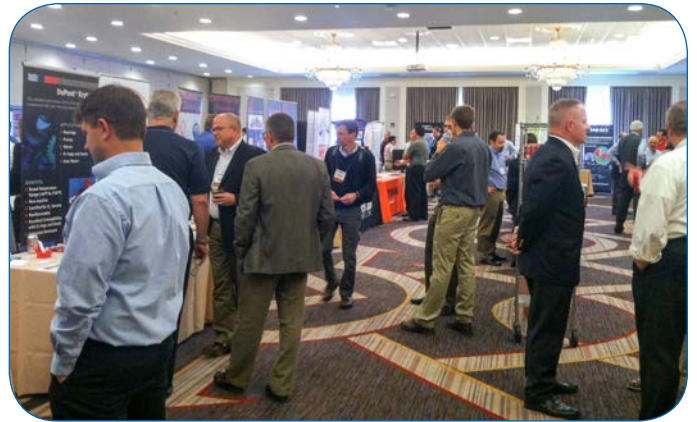

EMERF PCEMRC Update: Design of Ferrite Assisted Synchronous Motor (Fa-SrnRM) with Aluminum Conductors in Stator. Research project of the EMERF Pre-Competitive Electric Motor Research Consortium (PCEMRC) with Texas A&M University John Calico, Senior Research Engineer, Moog Components Group, and EMERF President.

Control Aspects of Various Electric Motors. Dal Y. Ohm, PhD, President, Drivetech Inc.

Effects of Magnetic Laminate Processing on Core Losses and Permeability. Aleta Wilder, PhD, Wilder Innovations LLC and The University of Texas; and Tapan Shah, Tanjore Jayaraman and Stephen Marr, Carpenter Technology Corp., Specialty Alloys Operations.

Meanwhile, as all of this was going on, a handful of short-but-informative motor courses was being presented on-site by industry luminaries. They included:

Evaluating Motor Power Efficiency in Small and Large Electric Motors. Instructor: Daniel B. Jones, President, Incremotion Associates Inc., and winner of the 2014 EMERF Award for "Outstanding Contributions (54 years) to the Electric Machines Industry."

Fundamentals of Brushless DC Motor Design. Instructor: William H. Yeadon, PE, president of Yeadon Energy Systems Inc. He is the author of many motor-related short courses and editor of the *Handbook of Small Electric Motors*.

Fundamentals of Materials for Electric Motors. Instructor: Aleta T. Wilders. Wilder has over 30 years of experience in process development and performance improvement based on materials science & engineering.

For more information:

SMMA
P.O. Box P182
S. Dartmouth, MA 02748
Phone: (508) 979.5935
Fax: (508) 979.5845
info@smma.org
www.smma.org

January 5-9 – SciTech 2015 Kissimmee, FL. SciTech 2015 will draw more than 3,000 participants from 40 countries and feature more than 2,500 technical papers, including the best papers from students around the world. Bringing together 11 individual technical events at a single location, this forum is the place to engage with colleagues within each discipline and to interact with experts in those fields. Discuss the science, technologies, policies and regulations that are shaping the future of aerospace. Walk away with innovative solutions that will create new opportunities and overcome challenges. For more information, visit www.aiaa-scitech.org.

January 26-28 – 2015 AHR Expo McCormick Place, Chicago, IL. The show brings together over 2,000 exhibiting companies and 40,000 visitors, representing the entire spectrum of the industry, HVACR manufacturers, engineers, contractors, OEMs, facility managers and other professionals. In addition, attendees will find over 100 educational seminars, workshops (presented by ASHRAE and others) and new product presentations. Those looking to keep up with the latest technology and trends, get face to face with the experts, and stay connected will enjoy this event. For more information, visit www.ahrexpo.com.

February 4-6 – SEMICON Korea 2015 COEX, Seoul, Korea. SEMICON Korea 2015 is the leading semiconductor technology event to explore the latest market trends and future developments for technology, featuring extensive technical forums, business programs and standards programs. For more information, visit www.semiconkorea.org.

February 10-12 – MD&M West Conference Anaheim Convention Center, Anaheim, CA. Delve into the latest challenges and opportunities that are impacting medical device design and manufacturing with the 2015 MD&M West Conference. Attendees can hear from the industry's brightest and gain valuable insights that will help them overcome the most crucial challenges from concept to market. Build knowledge and networks at this annual industry gathering. For more information, visit <http://mdmwest.mddionline.com>.

February 15-18 - 2015 SME/CMA Annual Conference Colorado Convention Center, Denver, CO. Taken as a whole the international mining industry is softening as the global economy expands at a more moderate pace and mine capacity may have outstripped demand in the short term. However, in the individual mining sectors of coal, metal, industrial minerals and aggregates, opportunities await for smarter companies that are meeting their own domestic and international challenges by opening new markets, creating new products, cutting costs and improving efficiencies. This multi-industry sector panel will address both the opportunities and challenges that lie ahead for each mining sector. Badges are required for admittance. All food and beverage functions held each day in the Expo Hall will be located in the SME Conference Café, lounge and two restaurants. For more information, visit www.smeannualconference.com.

February 15-18 - Middle East Turbomachinery Symposium Sheraton Doha Resort & Conference Hotel, Doha, Qatar. The 3rd Middle East Turbomachinery Symposium, held 17-20 March 2013 in Doha, is the premier turbomachinery event in the Middle East, combining a world-class technical conference and international exhibition. Technical sessions offer delegates continuing education credits while the exhibit hall featured over 65 industry-leading companies. For more information, visit <http://mets.tamu.edu>.

March 4-7 – The MFG Meeting Orlando World Center Marriott, Orlando, FL. The MFG Meeting brings together the entire manufacturing industry for a unique conference experience that provides unparalleled educational and networking opportunities. Engage with the industry's thought leaders and discuss business solutions with peers – all in one place. One of the highlights of this year's conference will be a training session with Michael Hoffman, President of Igniting Performance, a company that specializes in sales, leadership and building customer loyalty. His innovative program, "Secrets of the 1%ers," taps into the methods and the motivations of the best of the best – showing how they became influential – and how to replicate their success. For more information, visit www.themfgmeeting.com.

March 9-11 – SIAF Guangzhou 2015 China Import and Export Fair Complex, Guangzhou, China. The 2015 edition of SPS – Industrial Automation Fair Guangzhou is gearing up to be a must-attend industrial automation event in China. The event will cover over 40,000 square miles of exhibition space across four halls. Recognizing the importance and future growth prospects of the South China market, exhibitors are ready to present their latest collection of innovative solutions and products to international and domestic visitors. To date, over 300 exhibitors are confirmed to introduce the latest industrial automation technologies, including control systems, sensor technologies, software development, drive systems, components and much more for manufacturing-based industries. For more information, visit www.spsinchina.com.

March 23-26 – Automate 2015 McCormick Place North, Chicago, IL. Automate is the largest solutions-based showcase of automation technologies in North America. Automate demonstrates the full spectrum of automation technologies and solutions for a broad array of industries. Companies that provide integration of automation, robotics and machine vision will show actual demonstrations of systems that will allow attendees to see live demos solving challenges they face in their industry, and also to learn from solutions used in other industries that may be beneficial to them. The rest of the show features the latest automation, robotic, vision and motion control technologies and systems on display from leading global suppliers. A comprehensive educational conference accompanies the Automate show. Keynote speakers include Steve Wozniak, cofounder of Apple. For more information, visit www.automateshow.com.

Arrow Gear

Page 5
www.arrowgear.com

Automation Direct

Inside Front Cover
www.automationdirect.com

B&R Machine and Gear

Page 9
www.brgear.com

Baldor

Page 21
www.baldor.com

Beyta Gear Service

Page 88
www.beytagear.com

Brevini Gear

Pages 16, 41, 43, 44
brevinigeared.com

Brother International

Page 23
brothergearmotors.com

C&U Americas

Page 32
www.cubearing.com

Cabat Inc.

Page 2
www.cabatinc.com

Circle Gear

Page 25
www.circlegear.com

Cone Drive

Page 39
www.condedrive.com

Contitech North America

Page 35
www.contitech.us

Designatronics Inc.

Pages 34, 35, 40, 42, 45, Back Cover
www.designatronics.com

Diequa Corp.

Page 17
www.diequa.com

Excel Gear

Page 22
www.excelgear.com

First Gear

Page 11
www.first-gear.com

Forest City Gear

Page 13
www.forestcitygear.com

Hannover Messe

Page 77
Hannovermesse.com

IDC-USA

Page 29
www.idc-usa.com

KTR Corp.

Pages 39, 40
www.ktrcorp.com

Lafert North America

Page 15
www.lafertna.com

Langenberg & Co.

Page 89
www.langenberg-llc.com

Luoyang SBI Special Bearing Co. Ltd.

Page 10
www.sbibearings.com

Martin Sprocket & Gear

Page 31
www.martinsprocket.com

McInnes Rolled Rings

Page 27
www.mcinnesorlledrings.com

Ningbo Zhongyi Hydraulic Motor Co.

Page 33
www.zihyd.com

NSK Americas

Page 32
www.nskamericas.com/aip

QA1 Precision Products

Page 2
www.qa1.net/industrial

QTC Metric Gears

Page 45
www.qtcgears.com

Quality Bearings & Components

Page 34
www.qbcbearings.com

R+W America

Page 37
www.rw-america.com

Schaeffler Group

Page 7
www.schaeffler.us

SEW-Eurodrive

Inside Back Cover
www.seweurodrive.com

SKF

Page 3
www.skf.com

Smalley Steel Ring Co.

Page 26
www.smalley.com

Sterling Instrument

Outside Back Cover, 42, 45
www.sdp-si.com

Stock Drive Products

Outside Back Cover, 35, 40
www.sdp-si.com

Worldwide Electric Corp.

Page 34
www.worldwideelectric.net

Yaskawa America Inc.

Page 19
www.yaskawa.com

CALL FOR PAPERS!

Are you sitting on an idea for a technical paper but wondering where to present it? Do you have one already written, sitting on your desk, gathering machine dust?

How about *Power Transmission Engineering*? We are always looking for gearing- and power transmission component-relevant technical papers for publication in the magazine and in its digital version. Having your work appear in *Power Transmission Engineering* guarantees you an audience of the most experienced and discriminating industry players. You say your work has not been peer-reviewed? Not a problem, as we are lucky—and thankful—to have on-hand

some of the most experienced and brilliant minds in the industry—our technical editors. So if your work “passes muster” and is published, you’ll know you were reviewed by the best—and most demanding.

Chances are you’ll be creating the paper under the auspices of the company for whom you work or own, or for one of the various industry-relevant associations. That means they as well will bask in the reflected glory that accrues with publication in *Power Transmission Engineering*.

For publication guidelines and more information, please contact Jack McGuinn at jmcguinn@powertransmission.com.

Power Transmission Engineering

Power Transmission Engineering

is Your KEY to understanding Gears, Gear Drives, Bearings, Motors, Clutches, Couplings, Brakes, and other Power Transmission Components.

Unlock your FREE subscription by filling out this form.



FREE SUBSCRIPTION

1 **YES** I want to receive/continue to receive **Power Transmission Engineering FREE!**
 No thank you.

Name: _____ JobTitle/Position: _____
(print)

Signature _____ Date: _____
(required)

2 → E-mail _____
(So we can notify you when the online edition is available)

 **SAVE a TREE!**
 I ONLY want the digital edition (e-mail required)

3 → Please update your contact information or attach you business cards here. (No Staples)

Company Name: _____
 Address: _____

 City: _____
 State/Province: _____ ZIP/Postal Code: _____
 Country: _____
 Telephone: _____ Fax: _____
 E-mail: _____
 Website: _____

5 → What is your primary job function responsibility? (Check one)

<input type="checkbox"/> Corporate Management (1)	<input type="checkbox"/> Quality Control (7)
<input type="checkbox"/> Plant Engineering (2)	<input type="checkbox"/> Factory Automation (8)
<input type="checkbox"/> Design Engineering (3)	<input type="checkbox"/> Maintenance (9)
<input type="checkbox"/> Marketing & Sales (4)	<input type="checkbox"/> Other (10)
<input type="checkbox"/> Manufacturing Engineering (5)	_____
<input type="checkbox"/> Purchasing (6)	

Is there a colleague within your company that might benefit from having their own copy of **Power Transmission** magazine?

Name: _____
 Title: _____

4 → How is THIS LOCATION involved with power transmission products? (Check all that apply)

WE MAKE power transmission products (10)
 WE BUY power transmission products (12)
 WE SELL power transmission products (Distributors, sales reps. etc.) (14)
 WE DESIGN products with power transmission components in them. (16)
 Other (please describe) (15) _____

DIGITAL SUBSCRIPTIONS

- YES, I want to be notified each issue when Power Transmission Engineering is available online**
- YES, I would like to receive Power Transmission Engineering's monthly e-mail newsletter**
- YES, I would like to receive Power Transmission Engineering's twice monthly e-mail Product Alerts**
- YES, I would like to receive 3rd-party e-mails from Power Transmission Engineering's advertisers and partners**
- YES, I would like to receive subscription renewal notices by e-mail**
- No, I do not wish to be contacted by e-mail.**

FAX TO 1-847-437-6618 or
VISIT US ONLINE AT
www.powertransmission.com/subscribe.htm

The Model T Ford: One Mean Machine

Some of us are old enough to have had say, great-grand-parents, for example, who when the occasion arose would casually refer to cars as “machines.” It sounded funny and arcane, and we would snicker under our breath. But of course the laugh was on us; back in the day—1910s through the 1930s—automobiles were commonly referred to as machines.

And the “machine” that ruled the streets in those days—and claimed what then was only the beginning of the greatest “middle class” demographic in the history of the world—was the Ford Model T—AKA Tin Lizzie, T-Model Ford and Model T. To be clear, however—Ford did not invent the automobile; cars had been around for many years.

What Ford did “invent” was *affordability*—at least in terms of car-buying. His then-state-of-the-art manufacturing processes allowed him to sell his cars to the working man—including his own assembly line workers—for around 300 bucks and still make him a millionaire many times over. At the time, it was a win-win of truly historic proportions on several levels—social, economic, etc.

“I will build a car for the great multitude,” said Ford. “It will be constructed of the best materials, by the best men to be hired, after the simplest designs that modern engineering can devise. But it will be so low in price that no man making a good salary will be unable to own one.”

Supporting the fact that the best ideas are often someone else’s, credit for the “assembly line” goes not (as it often does) to Ford but to another car guy—Ransom E. Olds—who mass-produced his Oldsmobile Curved Dash in 1901. But the invaluable, priceless refinements and sophisticated system advances during the production run of the Model T are attributed primarily to Ford and his fellow visionaries—who happened to be engineers.

But having one of these machines wasn’t much use if the thing didn’t work; not-a-problem. The Ford Model T (FMT) was a workhorse of the road, powered by an engine that was designed to be manufactured providing the horsepower. Let’s take a closer, under-the-hood look at the heart of the machine that moved America—the Ford Model T engine.

The Ford Model T Engine

The engine was an inline-four—all four cylinders cast into one engine block. This would prove to be BIG. The FMT’s “monobloc” design was known, but not particularly popular when production started in 1908; but it lent itself to mass production, showing Ford’s pioneering appreciation of focus on design for manufacturability. Of equal brilliance, the head was detachable. This not only further streamlined Ford’s plant process, but also made his future customers’ valve jobs easier and, therefore—cheaper.

By The Numbers

- Bore: 3¾" (95.25 mm)
- Stroke: 4" (101.6 mm) even
- Total displacement: 177 cu in (2,900 cc)
- Valve train: side-valve (flat-head) design
- Crankshaft: Three main bearings

The compression ratio was low by modern standards, but typical for the era, making the engine forgiving of poor fuel quality and minimizing cranking effort at starting.

Model T Transmission

The rear-wheel-drive FMT was designed with a three-speed, planetary gear-oriented transmission. It was controlled with three foot pedals and a lever that was mounted to the road side of the driver’s seat. The throttle

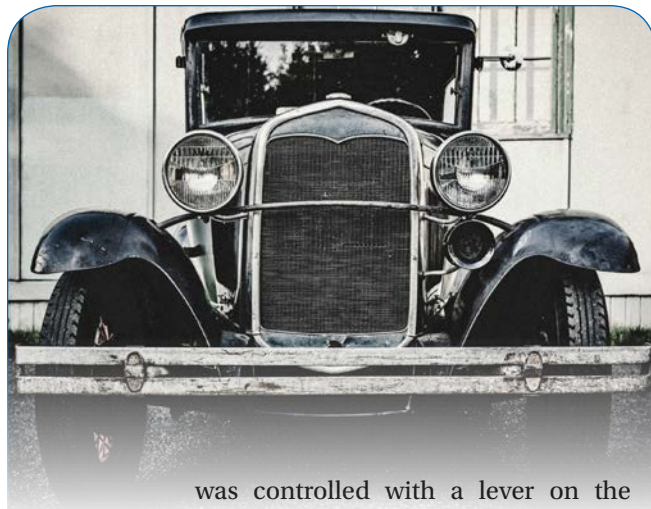

was controlled with a lever on the steering wheel. The left pedal was used to engage the gear.

- With the floor lever in either the mid position or fully forward, and the pedal pressed and held forward, the car entered **low gear**.
- When held in an intermediate position the car was in **neutral**.
- If the driver took his foot off the left pedal, the FMT entered **high gear**—but only when the lever was fully forward.

Oh, and by the way—no separate clutch pedal. And yet it sure seems like some very fancy footwork was required to drive one of these babies. And some nerves of steel.

When the car was in neutral, the middle pedal was used to engage **reverse gear**, and the right pedal operated the transmission brake.

There were no separate brakes on the wheels.

The floor lever also controlled the parking brake (no separate brakes on the wheels, but it had a friggig *parking* brake), which was activated by pulling the lever all the way back. Power was delivered to the differential via the single universal joint attached to a torque tube that drove the rear axle.

Appreciated for its simplicity, reliability, and economy, Ford’s Model T engine remained in production for many years; millions of units were produced. As for the engine *design*—it lived on beyond the vehicle itself, with industrial, marine, and military applications extending its production run. And one more thing: the Model T engine is on the Ward’s 10 Best Engines of the 20th Century list. (*Wikipedia.org was the primary source of information for this article.*) **PTE**

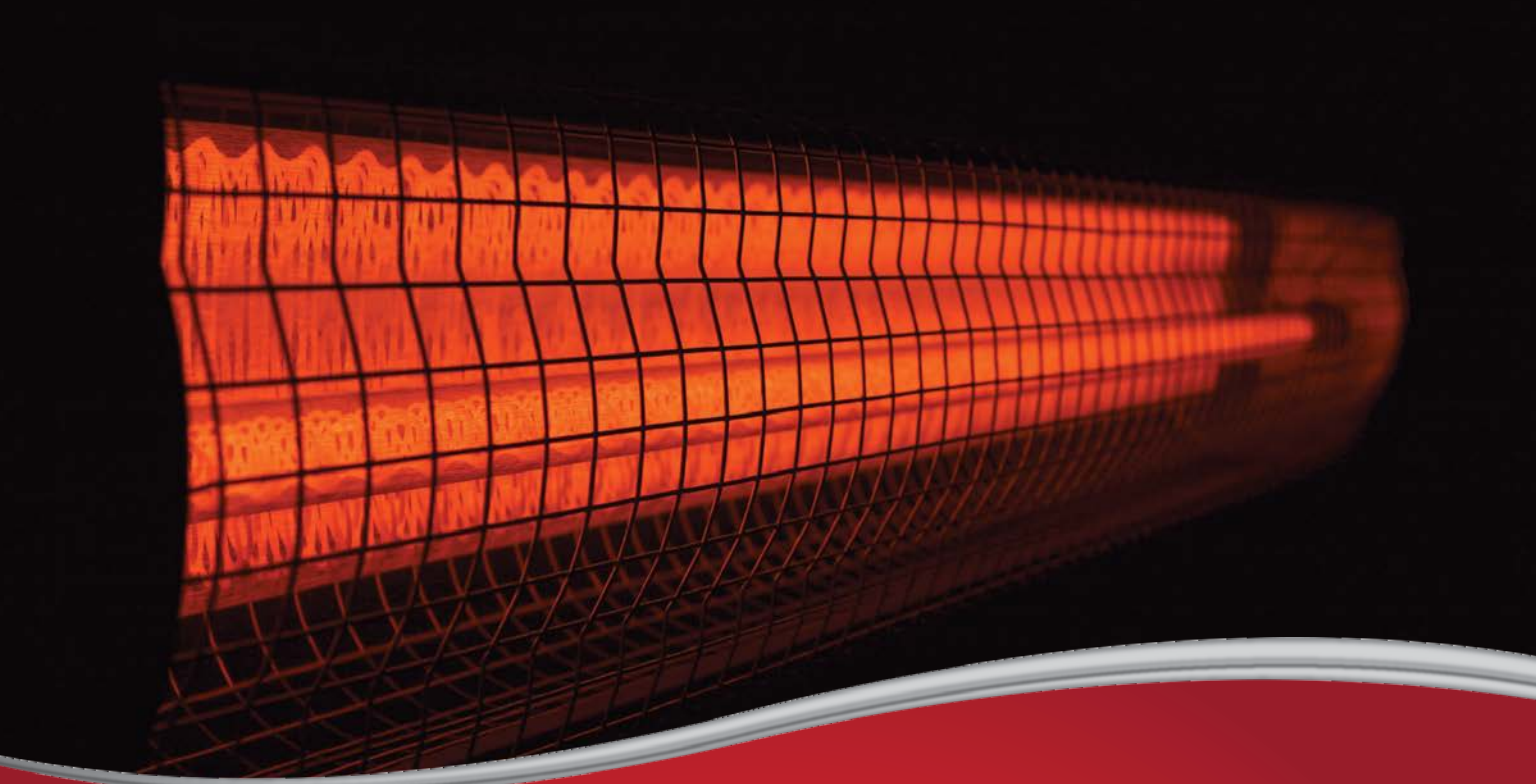

Things heating up at work?



Inefficient drive systems create heat. A bunch of drives generating heat raises your cooling costs. So, if you aren't using the ultra-efficient (IE4) MOVIGEAR® Mechatronic Drive System from SEW-EURODRIVE, then you are paying for energy twice! MOVIGEAR combines the motor, gearing and electronics into one highly reliable, efficient and hygienic unit. Independent research has proven that it reduces startup and operating costs by 20-30%. It's time to stop running the heat and air conditioning at the same time!

SEW
EURODRIVE



Stock Drive Products
Setting Ideas Into Motion

Your One-Stop Shop for Mechatronic Components

EXPLORE | DESIGN | BUY ONLINE

www.sdp-si.com/shop



**Thousands of inch & metric mechanical components:
gears, timing belts, pulleys, couplings & more
Custom belt widths cut to your specifications
Customized design and technical support
Get free 3D CAD models to use in your designs
AS9100C Registered**

Stock Drive Products

2101 Jericho Turnpike, New Hyde Park, NY 11040
Tel. (516) 328-3300 • sdp-sisupport@sdp-si.com
www.sdp-si.com